

Müşteri : FORD OTOSAN

Üretici (şirket) : DSS OTOMASYON

Proje adı : PLC101 stoper  
Proje numarası : 134679  
Kurulum yeri : Yeniköy Montaj Selectivite  
Proje açıklaması : Selektivite ALU Pnömatik Stoper Revizyonu

Pano Adı : PLC101 + A1.1  
Besleme : 24 VDC  
Kumanda gerilimi : 24 VDC  
Pano Ölçüleri : -

Üretim yılı : 2026  
Proje sonu :  
Proje çizen : Hasancan Simen  
Proje sorumlusu : Sabri Ebrem

Sayfa sayısı : 167



# SAFETY REGULATIONS



**DANGER!**

During plant operation certain items are under dangerous voltage!  
Non-observance of safety instructions can result in death, serious injuries or material damage.  
Only specialist personnel may carry out transport, installation and commissioning work.  
The applicable valid standards as well as the national and / or company-specific accident prevention regulations are to be observed.

The following safety instructions are to be observed

The erection, commissioning, troubleshooting as well as repair of the plant may only be carried out by qualified personnel that is familiar with the corresponding operating instructions.  
Mounting of the devices has to be effected in accordance with the valid standards, state and local regulations.  
Proper grounding and conductor dimensioning as well as proper short-circuit proofing have to be ensured.  
These measures serve to ensure the safety of the plant and of the operating personnel.  
Before carrying out safety checks, maintenance work and repair measures ensure that all the power supplies are switched off, are secured against being switched on unintentionally and are marked correspondingly.  
Only test devices that are in a technically perfect condition and are suitable for the respective measurement may be used to carry out measurements!  
The instructions specified in the respective operating instructions are to be followed strictly!  
It is mandatory that hazard, warning and safety instructions be observed!  
All doors and covers are to be kept closed during the plant operation.  
If cooling devices are installed in the plant, ensure that these systems operate trouble-free.  
These include the regular cleaning of the filters, in as far as they exist.



**DANGER!**

Süreç boyunca bazı parçalar tehlikeli gerilim altındadır!  
Güvenlik talimatlarına uyulmaması ölüme, ciddi yaralanmalara veya maddi hasara neden olabilir.  
Nakliye, kurulum ve devreye alma çalışmaları sadece uzman personel tarafından gerçekleştirilebilir.  
Geçerli standartların yanı sıra ulusal ve/veya şirkete özel kaza önleme yönetmeliklerine uyulmalıdır.

Aşağıdaki güvenlik talimatlarına uyulmalıdır.

Tesisin montajı, devreye alınması, arıza tespiti ve onarımı yalnızca ilgili çalıştırma talimatlarını bilen kalifiye personel tarafından gerçekleştirilebilir.  
Cihazların montajı, geçerli standartlara, eyalet ve yerel yönetmeliklere uygun olarak gerçekleştirilmelidir.  
Uygun topraklama ve iletken çaplarının yanı sıra uygun kısa devre koruması sağlanmalıdır.  
Bu önlemler tesisin ve işletme personelinin güvenliğini sağlamak içindir.  
Güvenlik kontrollerini gerçekleştirmeden önce, bakım çalışmaları ve onarım önlemleri, tüm güç kaynaklarının kapatıldığından, istenmeden açılmaya karşı emniyete alındığından ve uygun şekilde işaretlendiğinden emin olun.  
Ölçümleri gerçekleştirmek için sadece teknik olarak çalışır durumda olan ve ilgili ölçüm için uygun olan test cihazları kullanılabilir!  
İlgili çalıştırma talimatlarında belirtilen talimatlara kesinlikle uyulmalıdır!  
Tehlike, uyarı ve güvenlik talimatlarına uyulması zorunludur!  
Tesisin çalışması sırasında tüm kapılar ve kapaklar kapalı tutulmalıdır.  
Tesisin soğutma cihazları kurulu ise bu sistemlerin sorunsuz çalışmasını sağlayınız.  
Bunlar, var oldukları sürece filtrelerin düzenli olarak temizlenmesi gereklidir.



## Saha Kablolama Yöntemi

- Temel de kablo rafı ve kablo kanalı kullanılır.
- Motor devreleri, Ayrıca kullanılarak kontrol devrelerinden ayrılmalıdır.
- İletişim kabloları, aynı kanal içine monte edilmiş olsalar bile kontrol kablolarından ayrılacaktır.
- 'Blendajlı kablolar' kullanılırken panel tarafında topraklama yapılmalıdır.
- İşçilerin / operatörlerin erişebileceği ve / veya adım atabileceği yerlerde raf ve kapak gereklidir.

## Raf / Kanal Başına Kablolar İçin Çalışma

- Raf ve Kanal : kesitalanlarının %20'sinden az.
- Hortumlama : Hortum ölçülerinin %30'undan az.
- Kontrol Kabloları için yedek kablolar ( 10 kablo üzerinde ) : toplamın %10'u (minimum 2 kablo).

Aşağıda örnek verilen kablolama ve topraklama kurallarına uyulmalıdır.

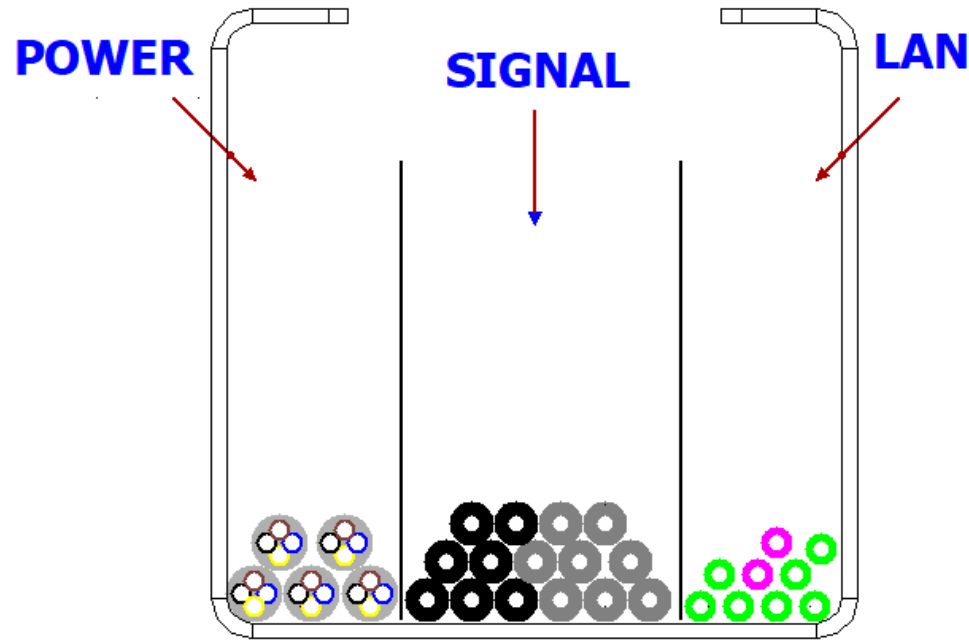

EARTH TRAY EXAMPLE

## Field Wiring Method

- Basically cable rack&cable duct are used
- Motor Circuits should be separated from the control circuits by using separator.
- Communication wires should be separated from the control wires even if they are installed in the same duct.
- 'Blendajlı kablolar' kullanılırken panel tarafında topraklama yapılmalıdır.
- İşçilerin / operatörlerin erişebileceği ve / veya adım atabileceği yerlerde raf ve kapak gereklidir.

## Raf / Kanal Başına Kablolar İçin Çalışma

- Raf ve Kanal : kesitalanlarının %20'sinden az.
- Hortumlama : Hortum ölçülerinin %30'undan az.
- Kontrol Kabloları için yedek kablolar ( 10 kablo üzerinde ) : toplamın %10'u (minimum 2 kablo).

The example you choose is to pay attention to the given wiring and grounding rules.

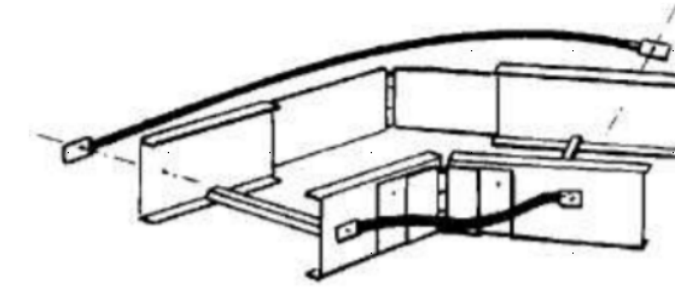

CABLE TRAY EXAMPLE



# TEKNİK UYGULAMA YÖNETMELİKLERİ / TECHNICAL

## SEMBOL YÖNETMELİKLERİ / SYMBOL REGULATIONS

-QS MAIN SWITCH	-QS ANA SALTER
-X TERMINAL	-X KLAMENS
-F FUSE	-F SIGORTA
-G POWER SUPPLY	-G GÜÇ KAYNAĞI
-T THERMOSTAT	-T TERMOSTAT
-M MOTOR	-M MOTOR
-CU CONTROLLER UNIT	-CU KONTROL ÜNİTESİ
-R RELAY	-R RÖLE
-S BUTON	-S BUTON
-Q THERMIQ	-Q TERMIK
-U CONVERTER	-U SÜRÜCÜ
-SS SOFT STARTER	-SS YUMUŞAK YOLVERİCİ
-K CONTACTOR	-K KONTAKTÖR
-B PROXIMITY SWITCH	-B PROX SENSÖR
-PP PHASE CONTROL	-PP FAZ KONTROL
-L SIGNAL LAMP	-L SİNYAL LAMBASI
-PS PRESSURE SWITCH	-PS BASINC SENSÖRÜ
-LS LEVEL SWITCH	-LS LEVEL SWITCH
-P POTANTIOMETER	-P POTANSİYOMETRE
-SL SELLECTOR SWITCH	-SL SEÇİM ANAHTARI
-A CONTROLER DEVICE	-A KONTROL CİHAZI
-BR BREAKER RESISTANCE	-BR FRENLEME DİRENCİ
-TS TEMPRATURE SWITCH	-TS SICAKLIK SENSÖRÜ
-ES EMERGANCY SWITCH	-ES ACİLSTOP
-SC SECURITY CIRCUIT	-SC GÜVENLİK DEVRESİ
-CHILLER UNIT	-CH SOĞUTMA ÜNİTESİ
-BOŞ	-BOŞ
-BOŞ	-BOŞ

## MALZEME YÖNETMELİKLERİ / MATERIAL REGULATIONS

### ŞALT PANOLARI / ENCLOSURES

Şalt panoları / Enclosures
Şalt panosu bazası / Enclosures base
Pano rengi / Enclosure color
Koruma sınıfı / Degree of protection

### KLEMENSLER / TERMINALS

2,5 mm <sup>2</sup> 'ye kadar	GRY
2,5 mm <sup>2</sup> 'ye kadar	BLUE
2,5 mm <sup>2</sup> 'ye kadar	YELLOW/GREEN
2,5 mm <sup>2</sup> 'ye kadar	GRY
2,5 mm <sup>2</sup> 'ye kadar	GRY

## KABLAJ YÖNETMELİKLERİ / WIRING REGULATIONS

### KABLAJ RENKLERİ / WIRING COLORS

Kumanda akım devresi AC > 380V	siyah (BL)
Kumanda akım devresi AC < 220V	kırmızı (RD)
Kumanda akım devresi DC > 24V	koyu mavi (BU)
Kumanda akım devresi GND	beyaz (WH)

### ASGARİ KESİTLER / MINIMUM CROSS-SECTIONS

Ana akım	1,5 mm <sup>2</sup>
Topraklama iletkeni	0,75 mm <sup>2</sup>
Kumanda hattı	1 mm <sup>2</sup>
PLC kablajı	1 mm <sup>2</sup>

### ASGARİ KESİTLER / MINIMUM CROSS-SECTIONS

4x0.22 mm <sup>2</sup>
6x0.34 mm <sup>2</sup>
2x2 0.75 mm <sup>2</sup>
2x0.75 mm <sup>2</sup>
4x0.75 mm <sup>2</sup>
6x0.75 mm <sup>2</sup>
8x0.75 mm <sup>2</sup>

Nötr iletkenler	mavi (BU)
Topraklama iletkeni klemensi	sarı-yeşil (GNYE)



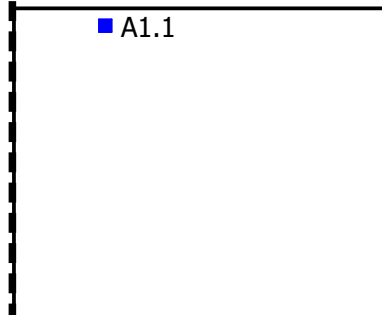
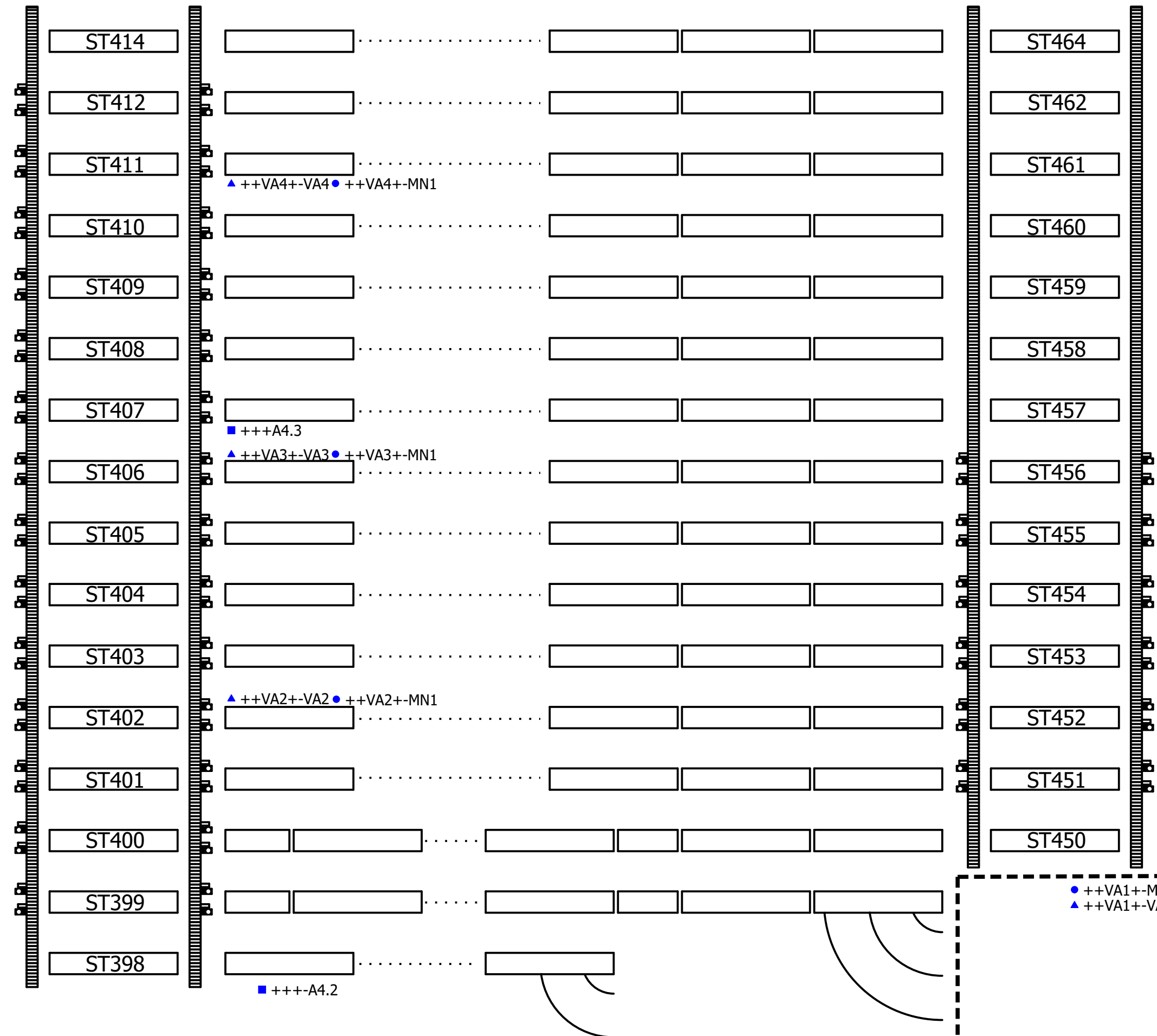

● ++VA1+-MN1  
▲ ++VA1+-VA1

■ +++-A4.2

▲ ++VA4+-VA4 ● ++VA4+-MN1

■ +++A4.3

▲ ++VA3+-VA3 ● ++VA3+-MN1

▲ ++VA2+-VA2 ● ++VA2+-MN1

5



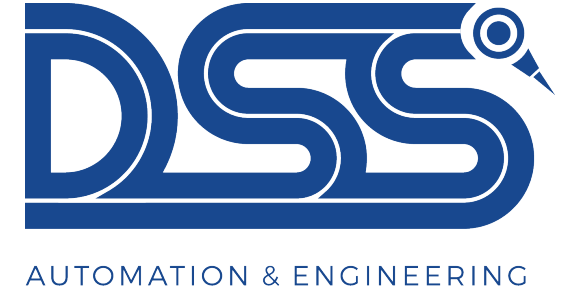



Müşteri : FORD OTOSAN

Üretici (şirket) : DSS OTOMASYON

+A2.1

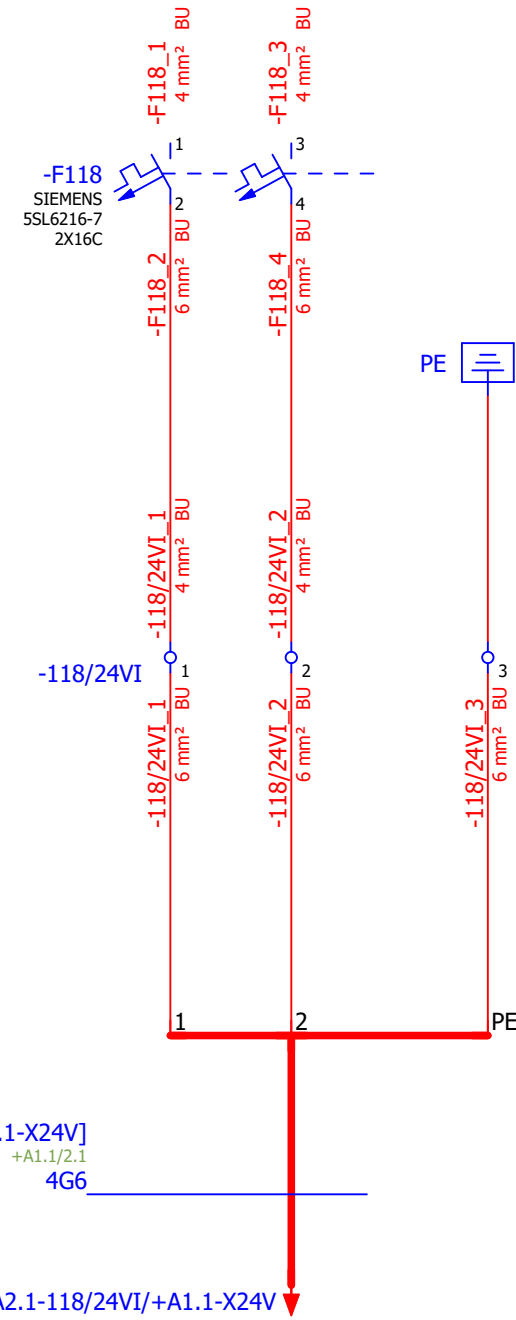



	Yeşilyurt, Muhtar Cafer Sk. No:8 41190 Başiskele/Kocaeli		<b>PROJE ADI</b>	<b>SAYFA AÇIKLAMASI</b>	Çizen: Hasancan Simen	Sayfa 2
	info@dssotomasyon.com.tr		PLC101 stoper	24VDC -VA BÖLGELERİ ANA SİGORTA	Kontrol Eden: Sabri Ebrem	++
	+90 544 322 23 10					+A2.1

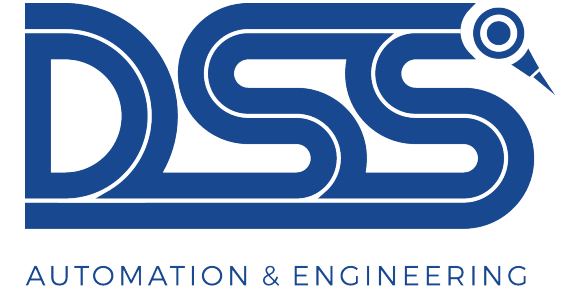

Müşteri : FORD OTOSAN

Üretici (şirket) : DSS OTOMASYON

+A1.1



	Yeşilyurt, Muhtar Cafer Sk. No:8 41190 Başiskele/Kocaeli		<b>PROJE ADI</b>	<b>SAYFA AÇIKLAMASI</b>	Çizen: Hasancan Simen	Sayfa 1
	info@dssotomasyon.com.tr		PLC101 stoper	KAPAK	Kontrol Eden: Sabri Ebrem	++
	+90 544 322 23 10					+A1.1

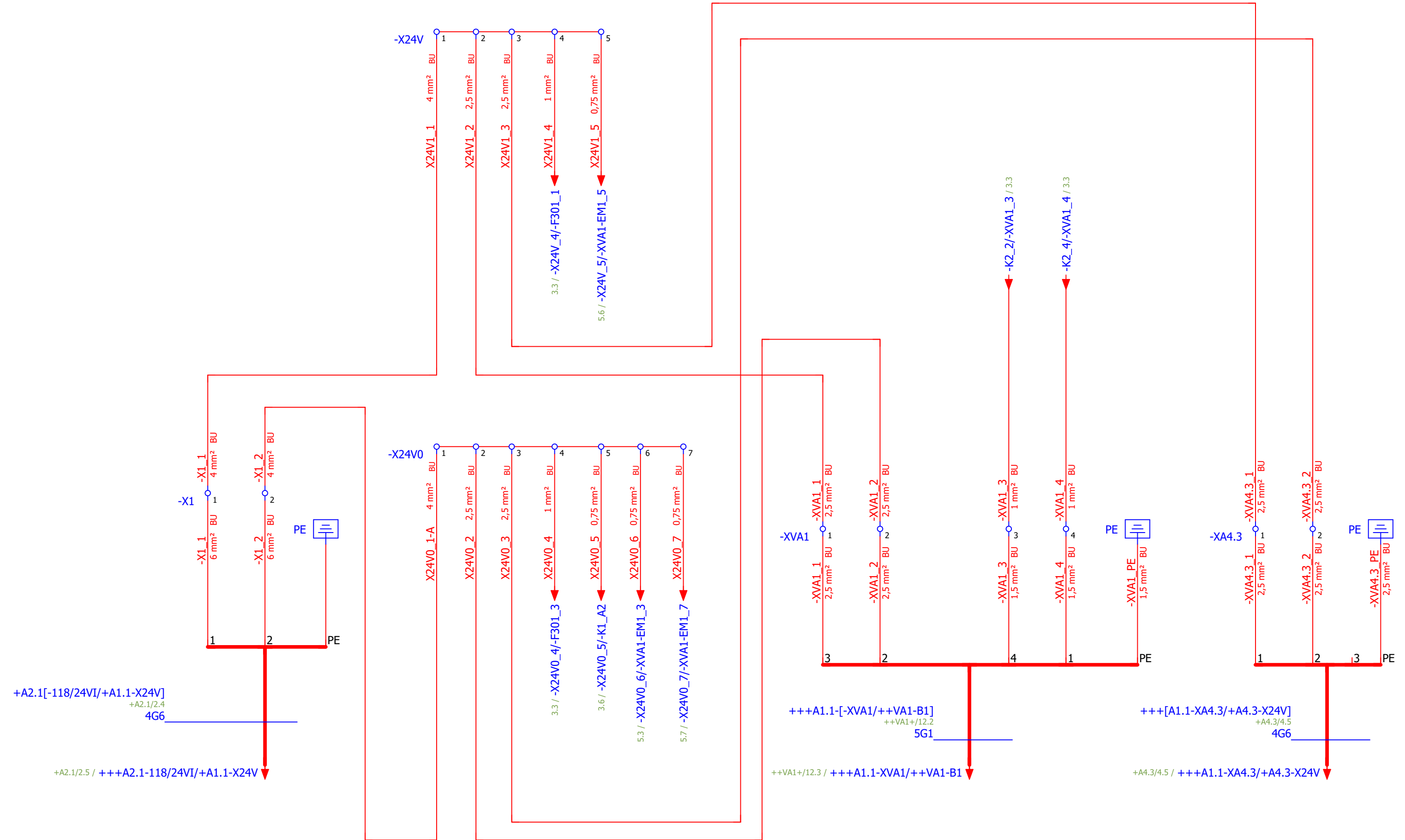

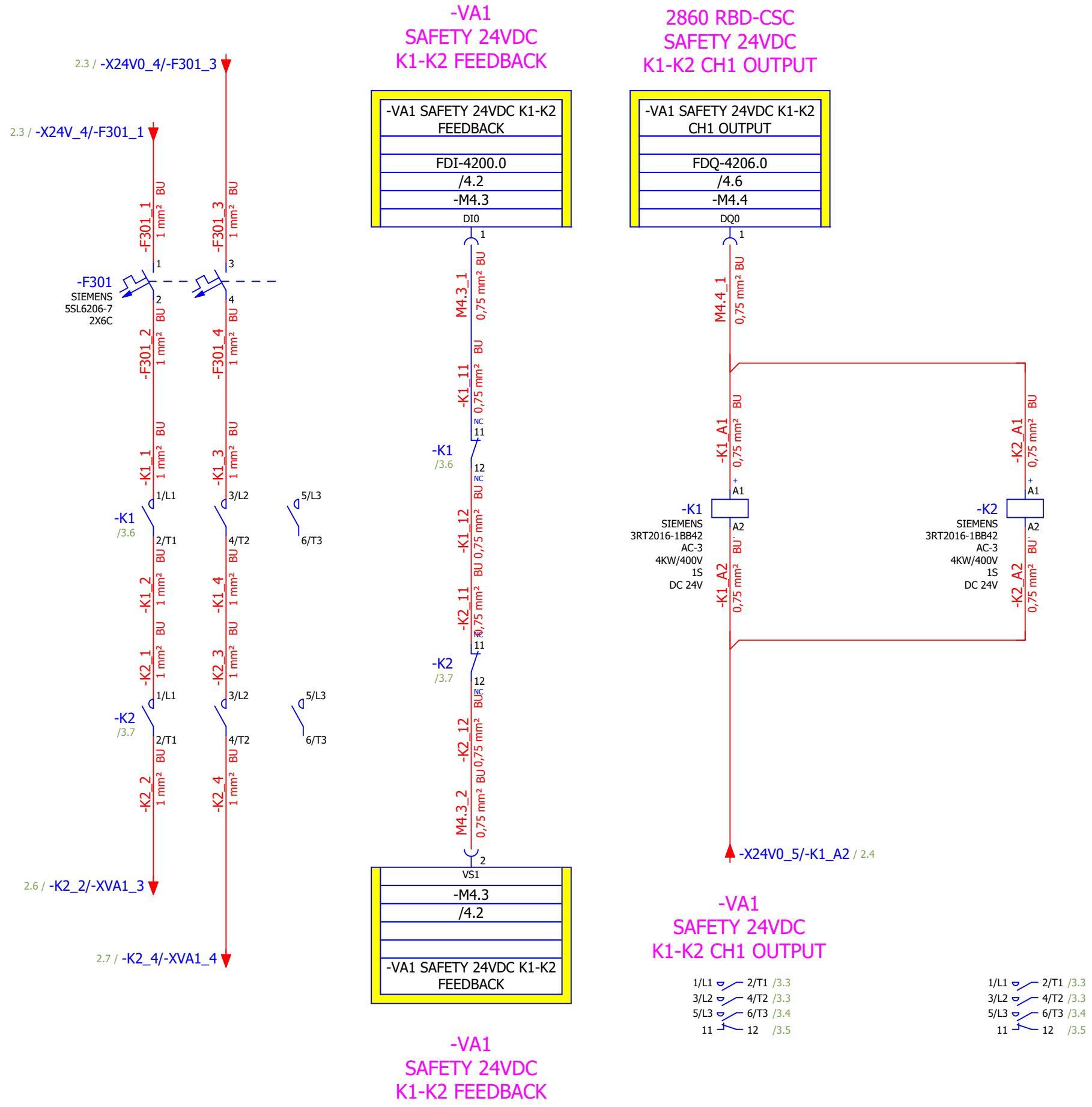

M4.3  
6ES7138-4FA05-0AB0

ET200S  
4/8 F-DI DC24V PROFI-safe

SIEMENS

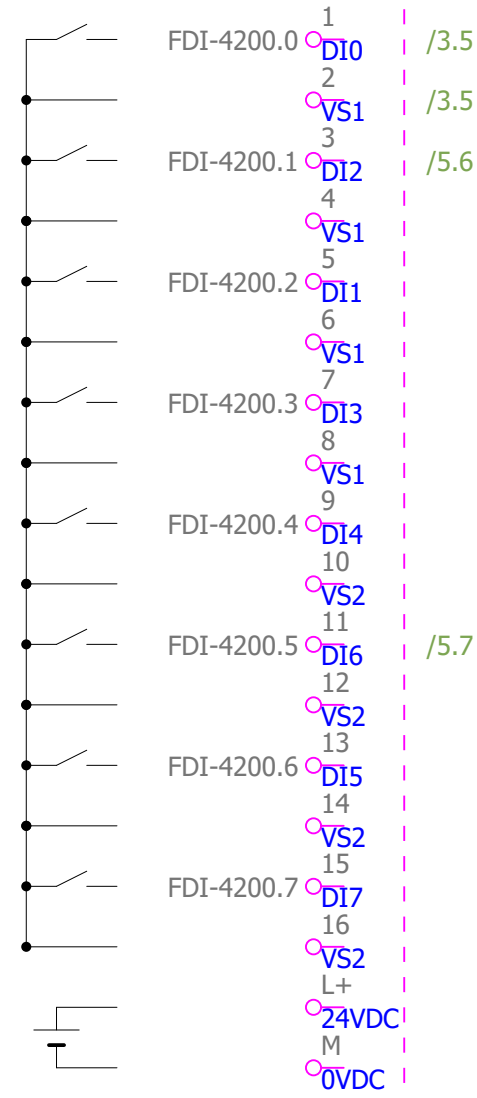

6ES7138-4FA05-0AB0

-VA1 SAFETY 24VDC K1-K2 FEEDBACK

-VA1 SAFETY 24VDC K1-K2 FEEDBACK

-VA1 SHUTOFF CH1 FEEDBACK

-VA1 SHUTOFF CH2 FEEDBACK

M4.4  
6ES7138-4FB04-0AB0

ET200S  
4 F DO DC24V 2A PROFI-safe

SIEMENS

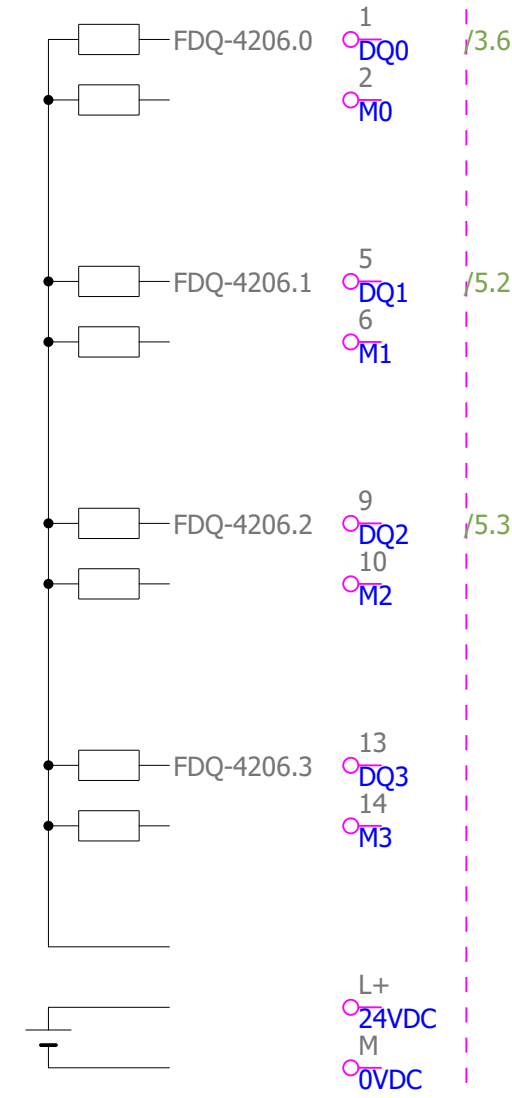

6ES7138-4FB04-0AB0

-VA1 SAFETY 24VDC K1-K2 CH1 OUTPUT

-VA1 SHUTOFF CH1

-VA1 SHUTOFF CH2



-VA1 SHUTOFF CH1

-VA1 SHUTOFF CH2

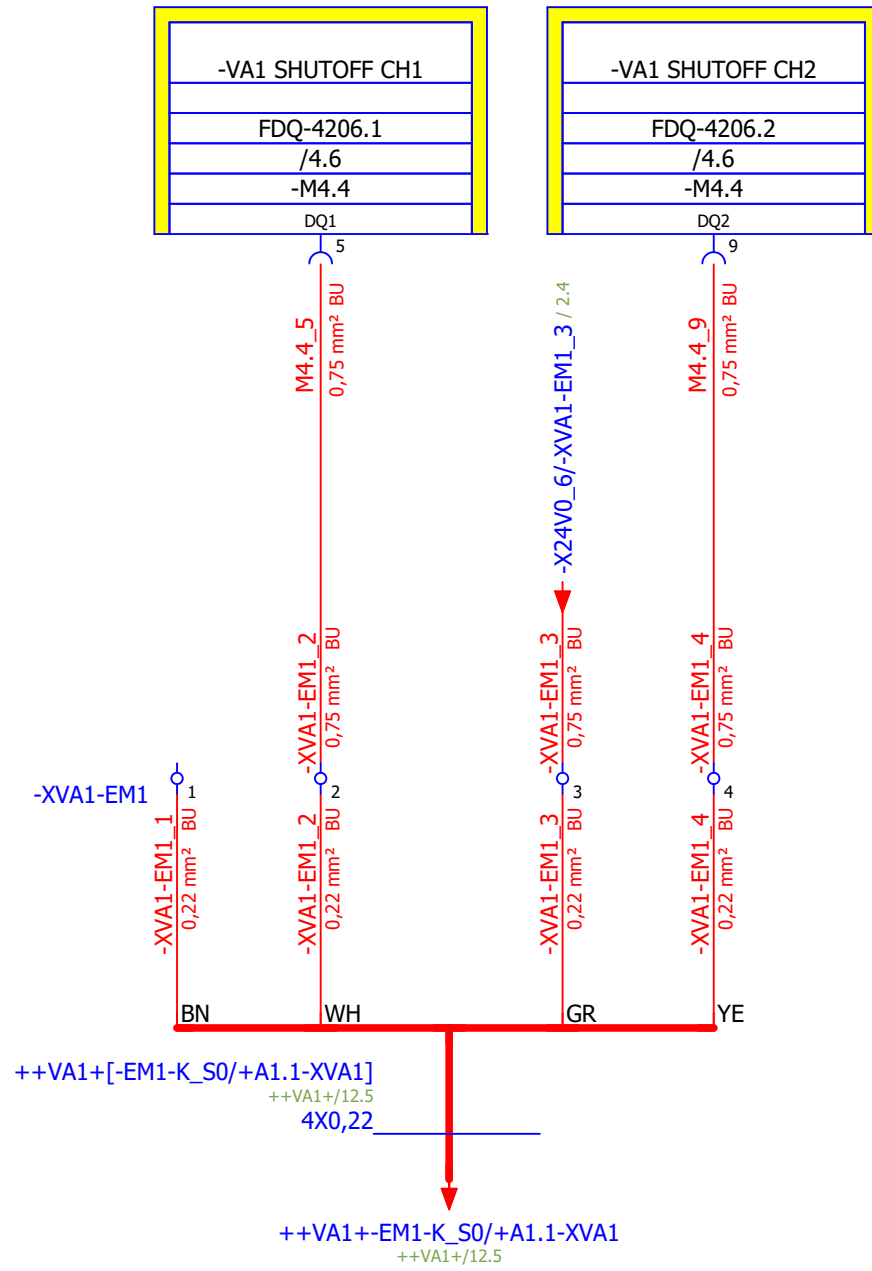

-VA1 SHUTOFF CH1

-VA1 SHUTOFF CH2

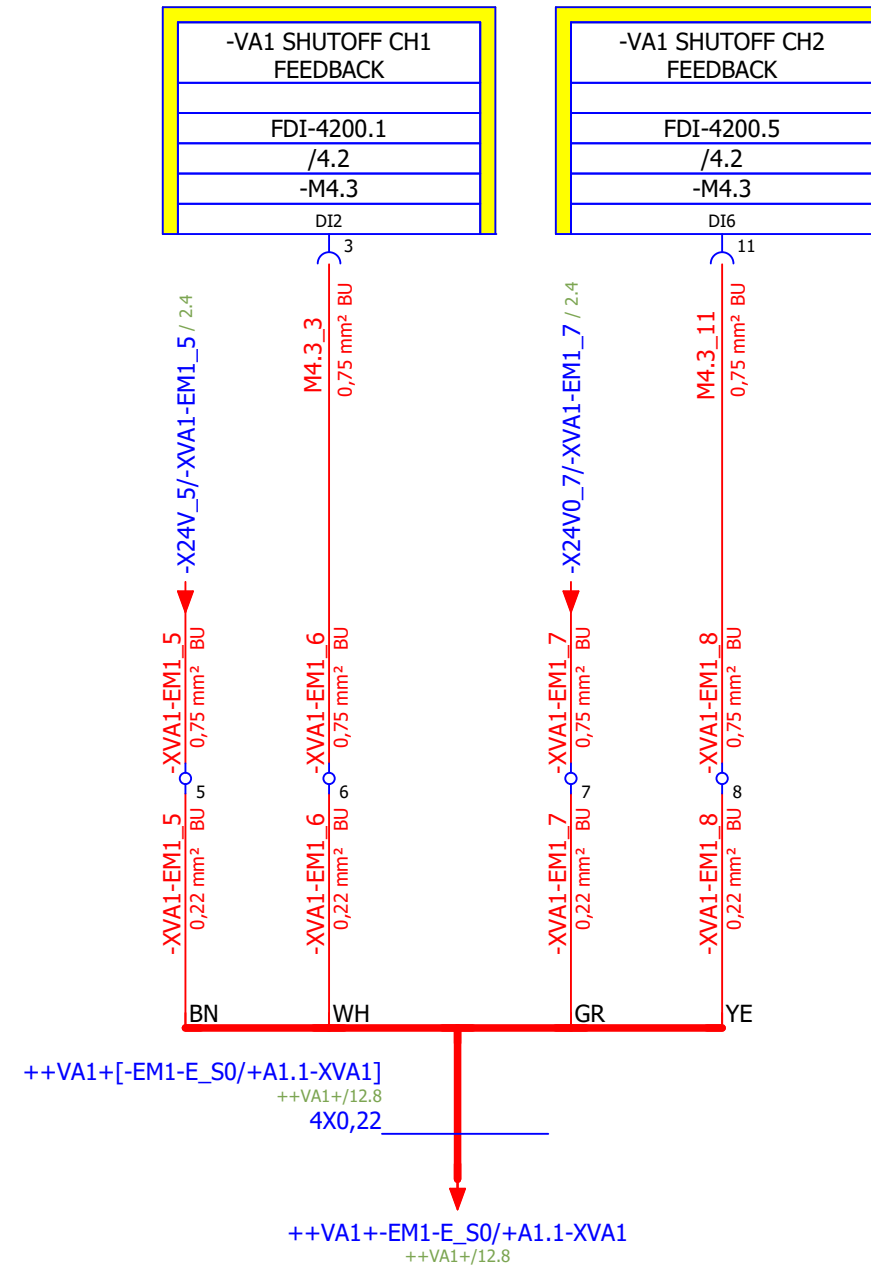

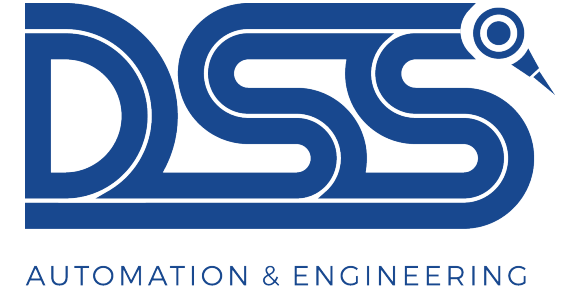

Müşteri : FORD OTOSAN

Üretici (şirket) : DSS OTOMASYON

+A4.2



1

	Yeşilyurt, Muhtar Cafer Sk. No:8 41190 Başiskele/Kocaeli		<b>PROJE ADI</b>	<b>SAYFA AÇIKLAMASI</b>	Çizen: Hasancan Simen	Sayfa 1
	info@dssotomasyon.com.tr		PLC101 stoper	KAPAK	Kontrol Eden: Sabri Ebrem	++
	+90 544 322 23 10					+A4.2

M5.2  
6ES7138-4FA05-0AB0

ET200S  
4/8 F-DI DC24V PROFIsafe

SIEMENS

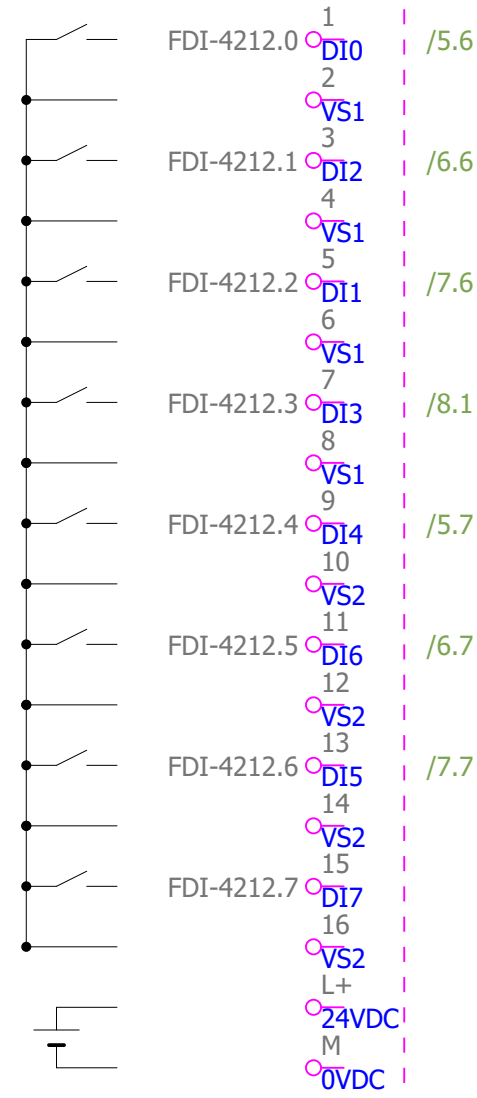

6ES7138-4FA05-0AB0

M5.3  
6ES7138-4FA05-0AB0

ET200S  
4/8 F-DI DC24V PROFIsafe

SIEMENS

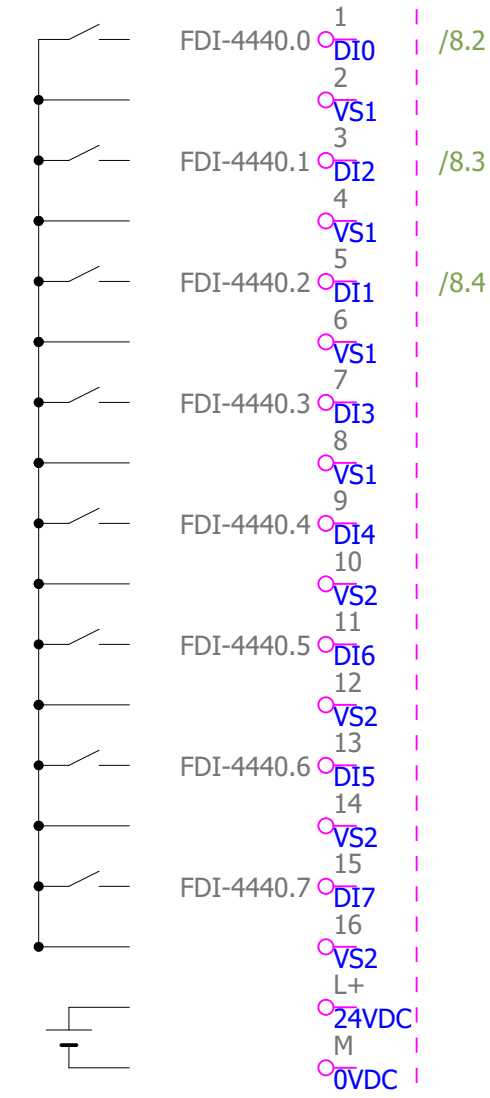

6ES7138-4FA05-0AB0

-VA2 SHUTOFF CH1 FEEDBACK

-VA3 SHUTOFF CH1 FEEDBACK

-VA4 SHUTOFF CH1 FEEDBACK

-VA2-VA3-VA4 S.F SİGORTA FEEDBACK

-VA2 SHUTOFF CH2 FEEDBACK

-VA3 SHUTOFF CH2 FEEDBACK

-VA4 SHUTOFF CH2 FEEDBACK

VA2 / -K3-K4 S.F. FEEDBACK

VA3 / -K5-K6 S.F. FEEDBACK

VA4 / -K7-K8 S.F. FEEDBACK



M5.4  
6ES7138-4FB04-0AB0

ET200S  
4 F DO DC24V 2A PROFIsafe

SIEMENS

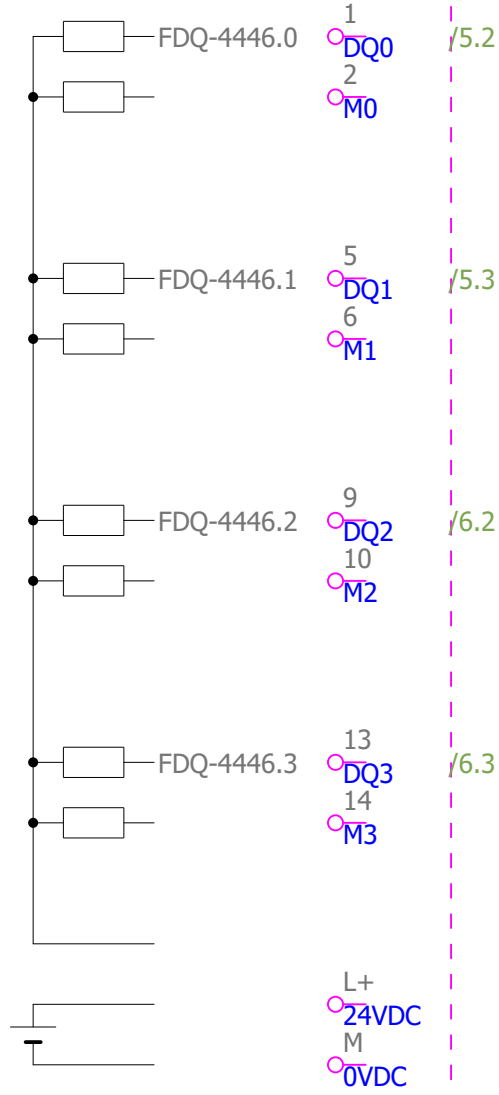

6ES7138-4FB04-0AB0

M5.5  
6ES7138-4FB04-0AB0

ET200S  
4 F DO DC24V 2A PROFIsafe

SIEMENS

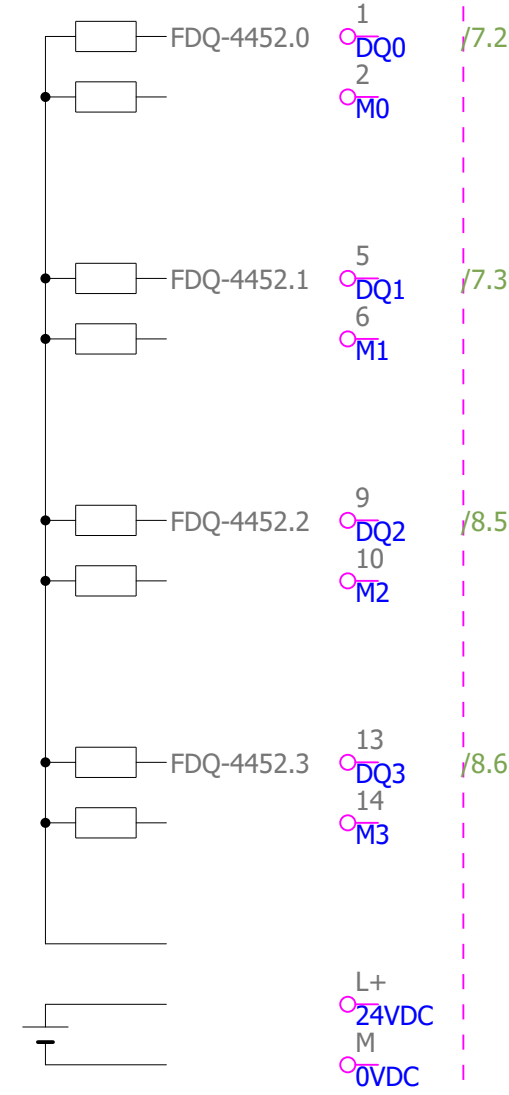

6ES7138-4FB04-0AB0

-VA2 SHUTOFF CH1

-VA2 SHUTOFF CH2

-VA3 SHUTOFF CH1

-VA3 SHUTOFF CH2

-VA4 SHUTOFF CH1

-VA4 SHUTOFF CH2

VA2 / -K3-K4 S.F.

VA3 / -K5-K6 S.F.



-VA2 SHUTOFF CH1

-VA2 SHUTOFF CH2

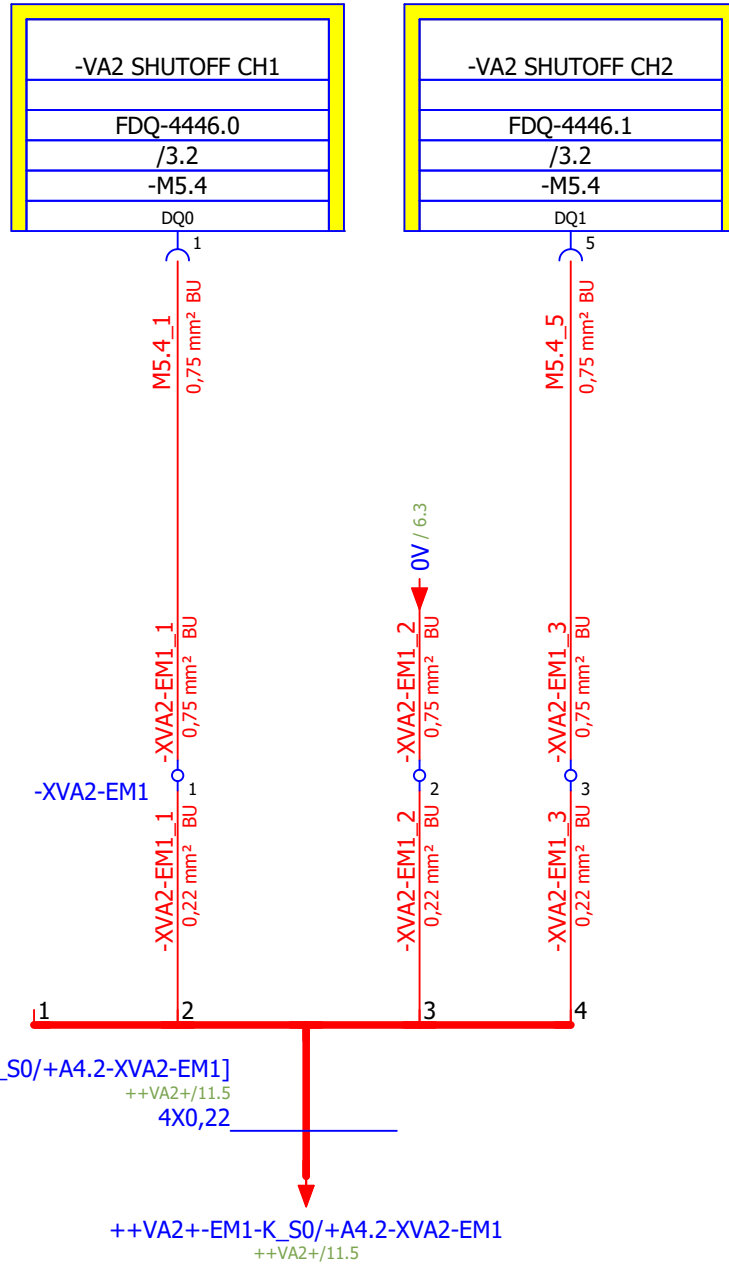

-VA2 SHUTOFF CH1

-VA2 SHUTOFF CH2

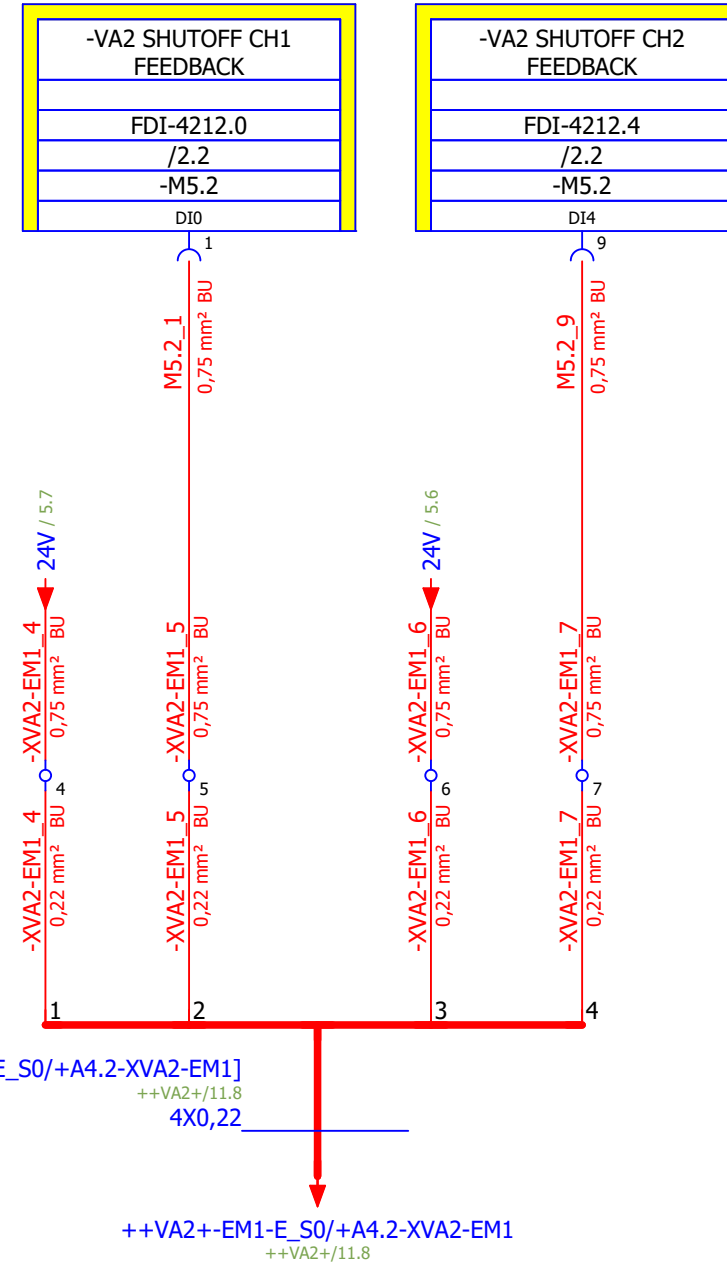

-VA3 SHUTOFF CH1

-VA3 SHUTOFF CH2

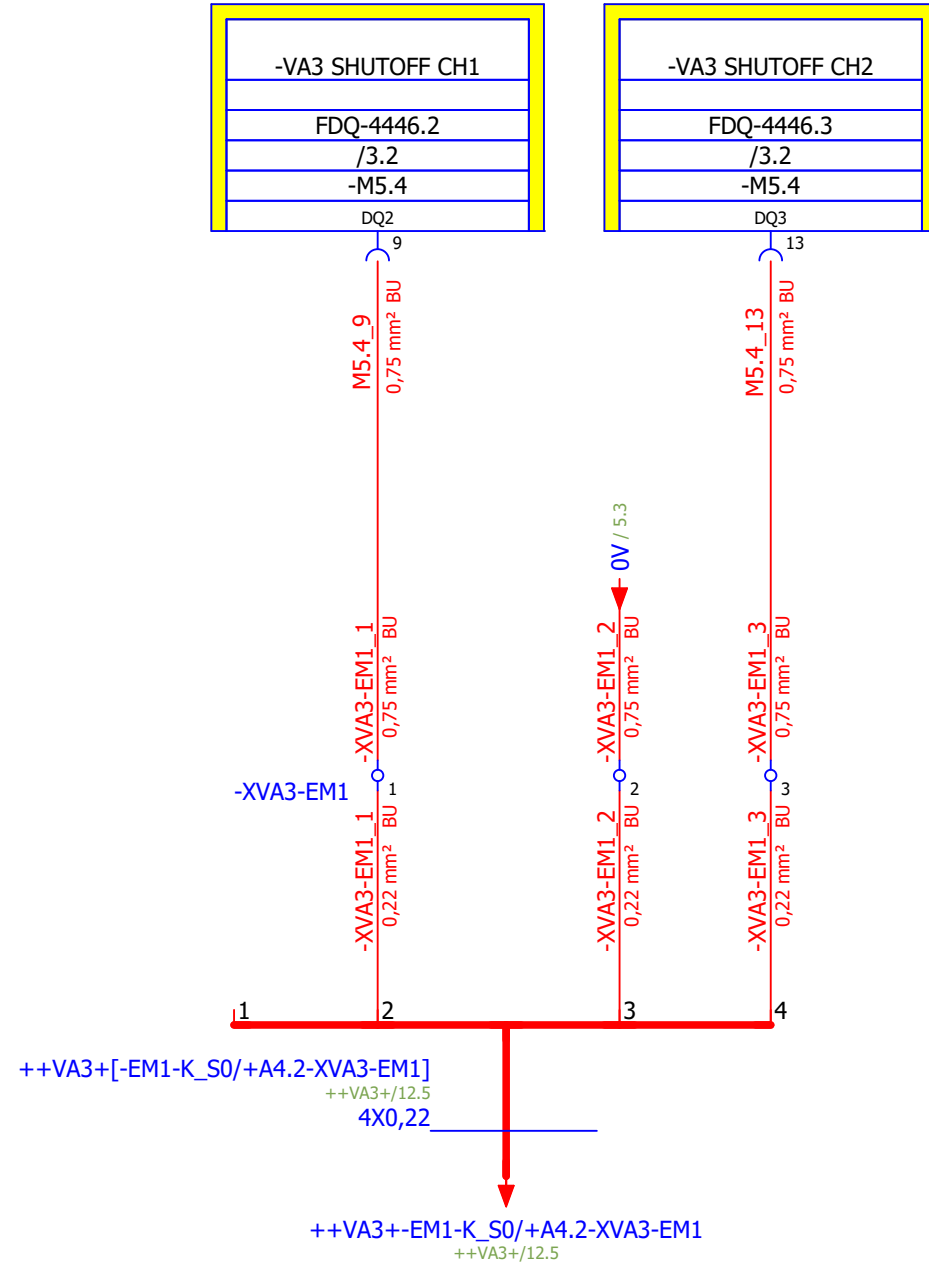

-VA3 SHUTOFF CH1

-VA3 SHUTOFF CH2

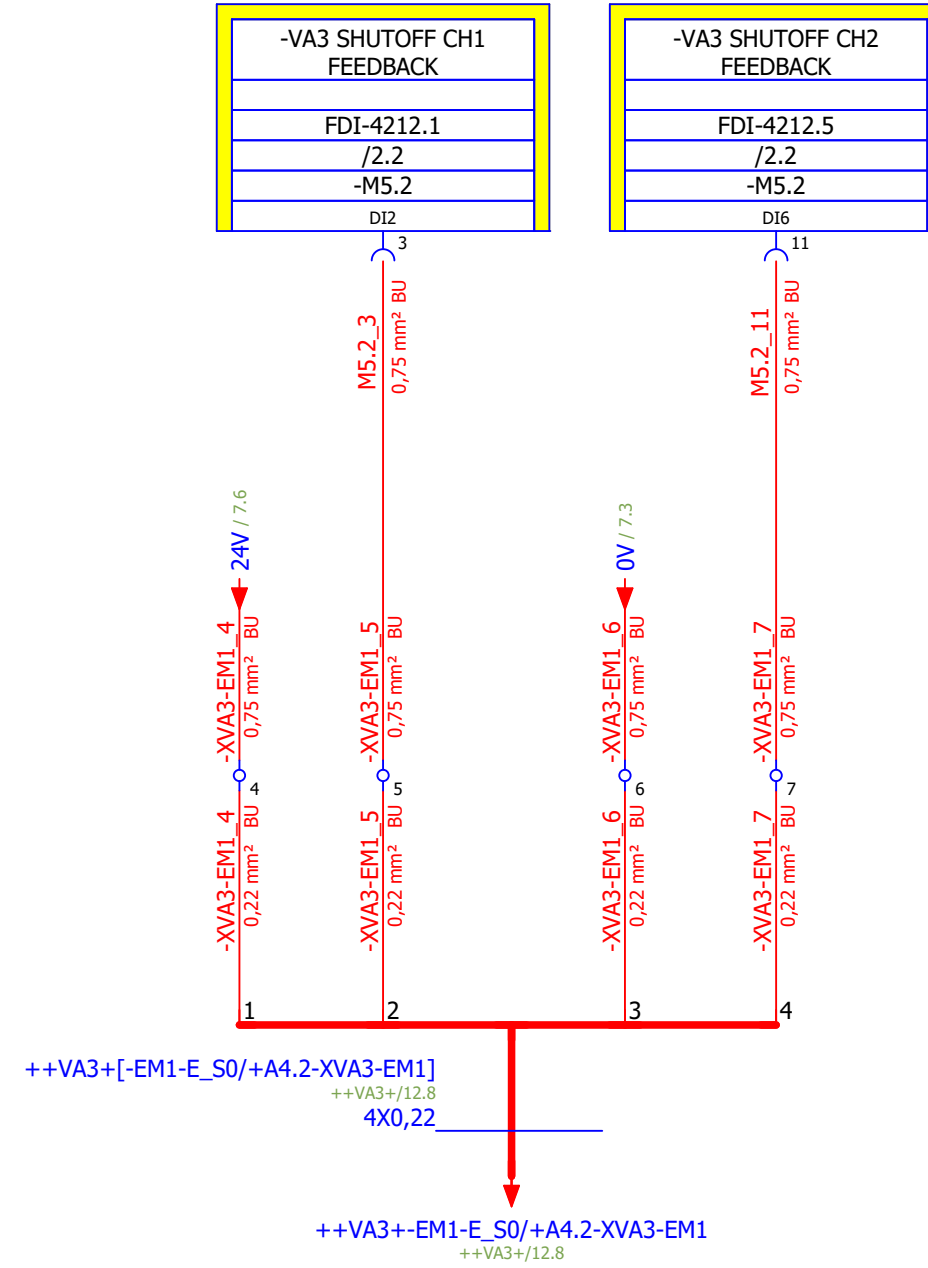

-VA4 SHUTOFF CH1

-VA4 SHUTOFF CH2

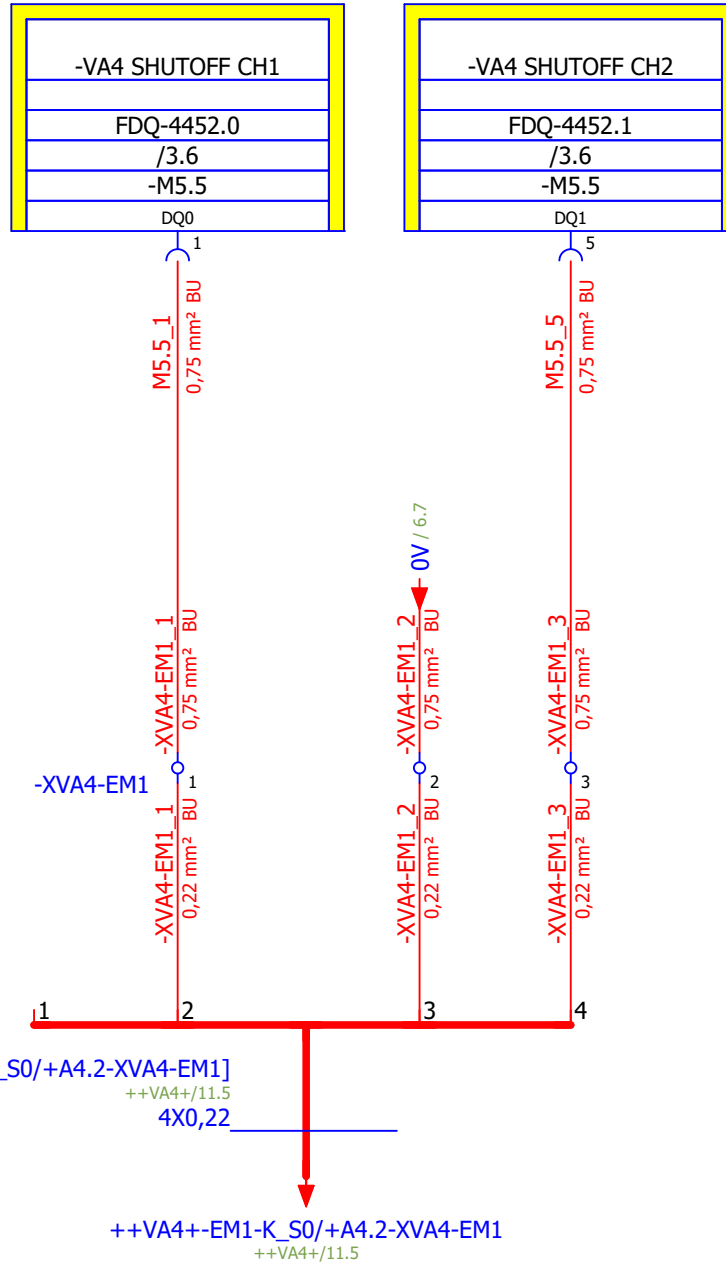

-VA4 SHUTOFF CH1

-VA4 SHUTOFF CH2

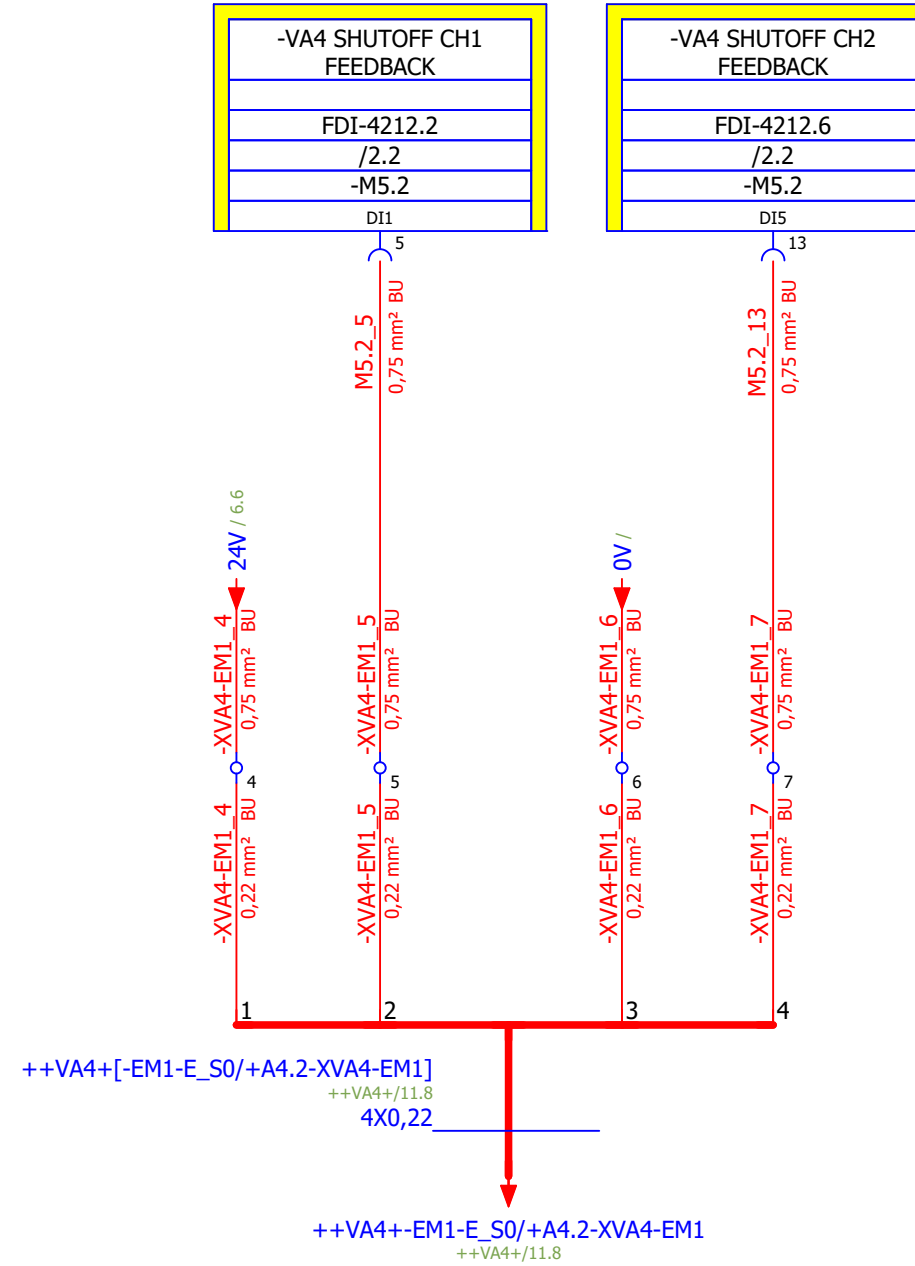

-VA2-VA3-VA4  
S.F SİGORTA FEEDBACK

VA2 / -K3-K4 S.F.  
FEEDBACK

VA3 / -K5-K6 S.F.  
FEEDBACK

VA4 / -K7-K8 S.F.  
FEEDBACK

VA2 / -K3-K4 S.F.

VA3 / -K5-K6 S.F.

VA4 / -K7-K8 S.F.

-VA2-VA3-VA4 S.F SİGORTA FEEDBACK
FDI-4212.3
/2.2
-M5.2
DI3

VA2 / -K3-K4 S.F. FEEDBACK
FDI-4440.0
/2.7
-M5.3
DI0

VA3 / -K5-K6 S.F. FEEDBACK
FDI-4440.1
/2.7
-M5.3
DI2

VA4 / -K7-K8 S.F. FEEDBACK
FDI-4440.2
/2.7
-M5.3
DI1

VA2 / -K3-K4 S.F.
FDQ-4452.2
/3.6
-M5.5
DQ2

VA3 / -K5-K6 S.F.
FDQ-4452.3
/3.6
-M5.5
DQ3

VA4 / -K7-K8 S.F.
FDQ-4458.0
-M5.1
DQ0

PE

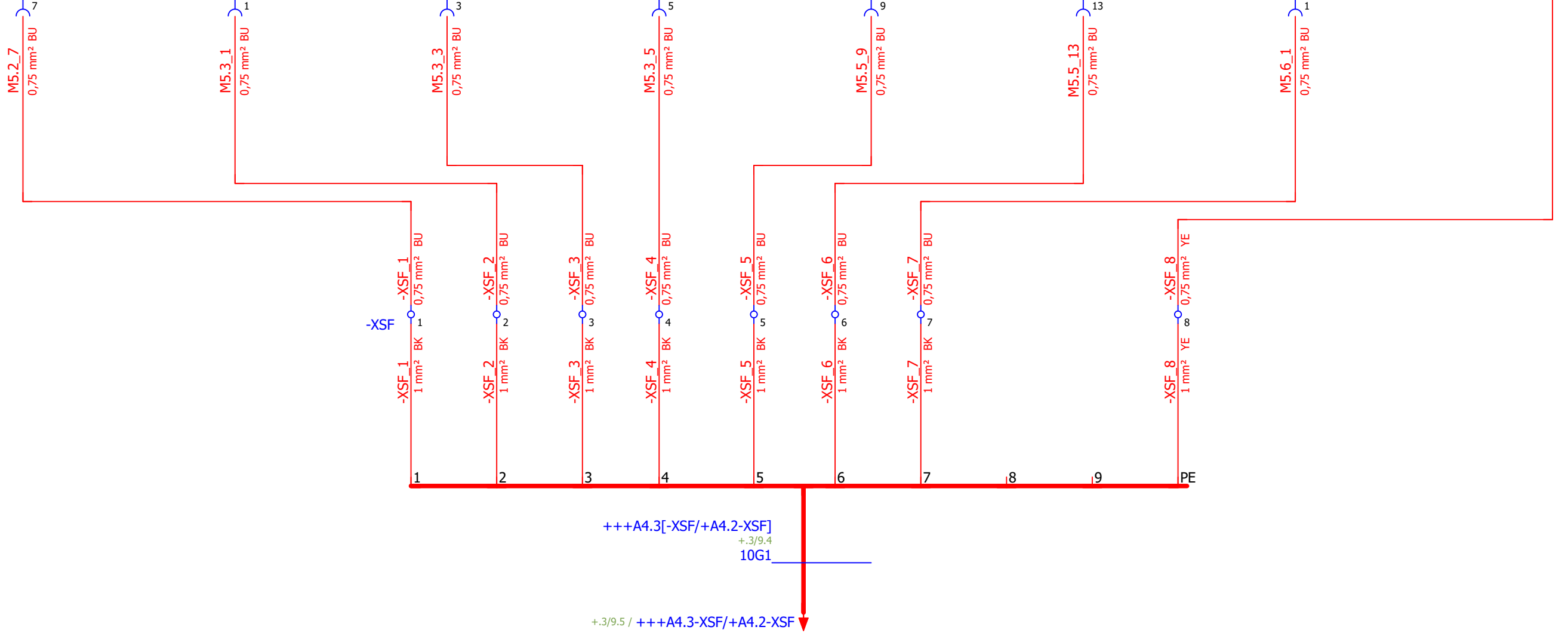

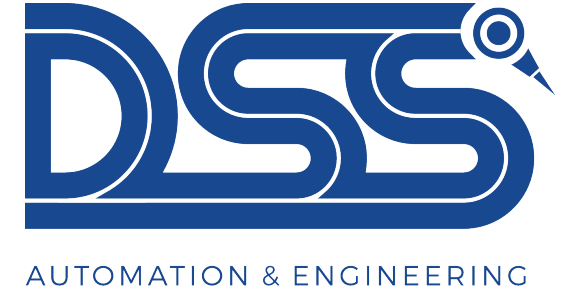

Müşteri : FORD OTOSAN

Üretici (şirket) : DSS OTOMASYON

+A4.3



1

	Yeşilyurt, Muhtar Cafer Sk. No:8 41190 Başiskele/Kocaeli		<b>PROJE ADI</b>	<b>SAYFA AÇIKLAMASI</b>	Çizen: Hasancan Simen	Sayfa 1
	info@dssotomasyon.com.tr		PLC101 stoper	KAPAK	Kontrol Eden: Sabri Ebrem	++
	+90 544 322 23 10					+A4.3

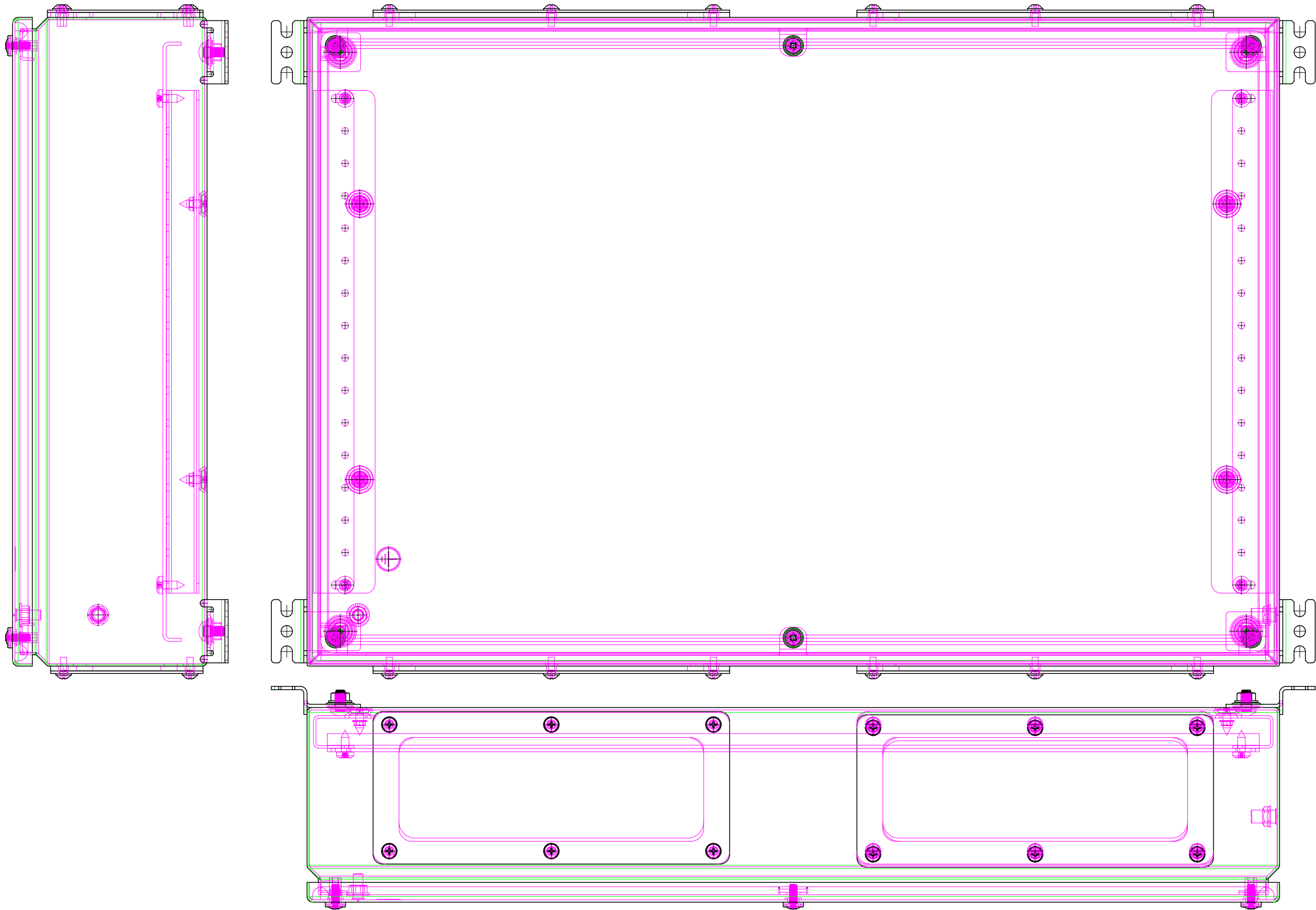

<b>PROJE ADI</b>
PLC101 stoper

<b>SAYFA AÇIKLAMASI</b>
BOX ÖLÇÜ

Çizen: Hasancan Simen
Kontrol Eden: Sabri Ebrem

++ +A4.3
-------------

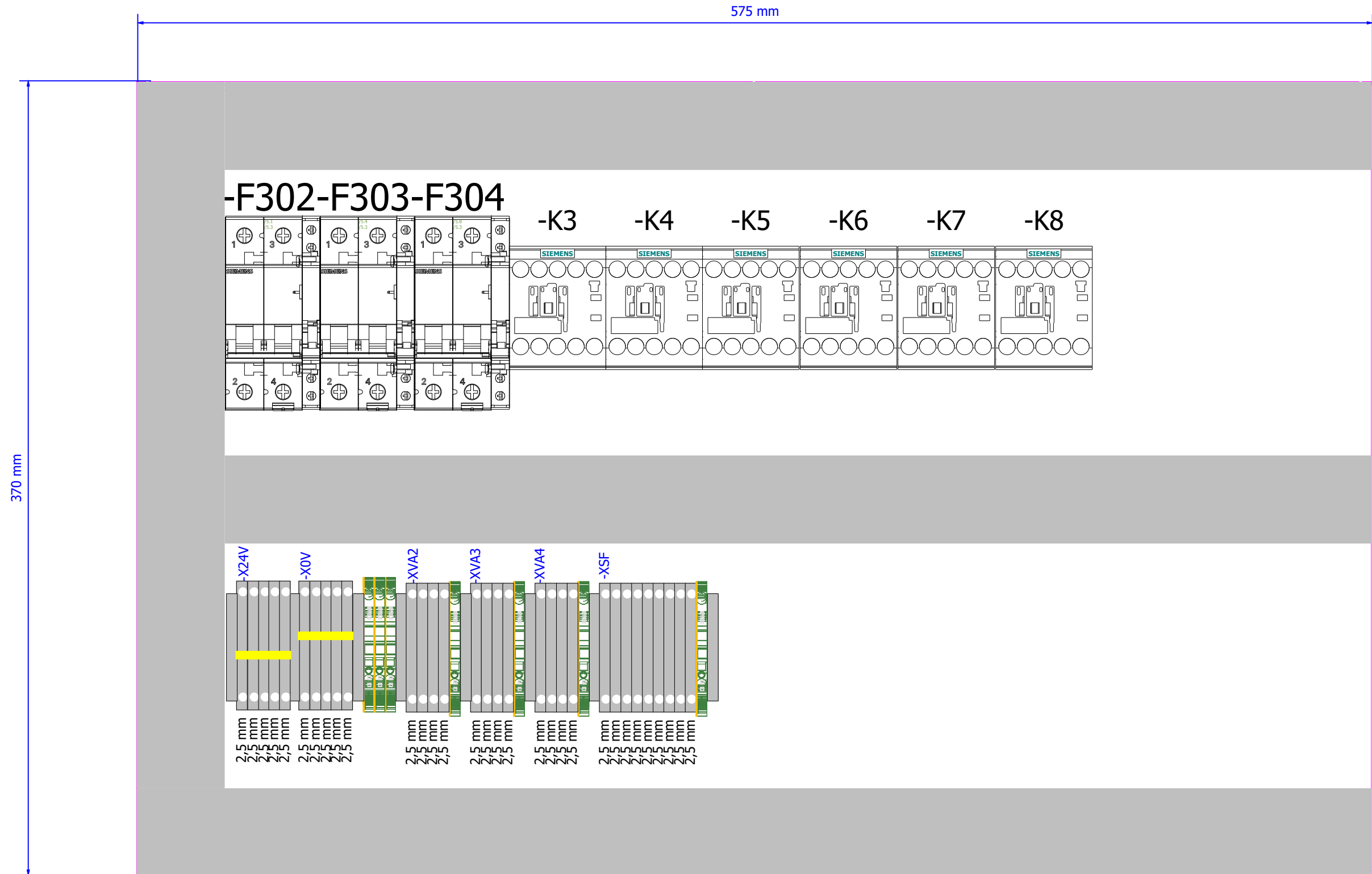

<b>PROJE ADI</b>	PLC101 stoper
------------------	---------------



<b>SAYFA AÇIKLAMASI</b>	MONTAJ PLAKASI
-------------------------	----------------

Çizen:	Hasancan Simen
Kontrol Eden:	Sabri Ebrem

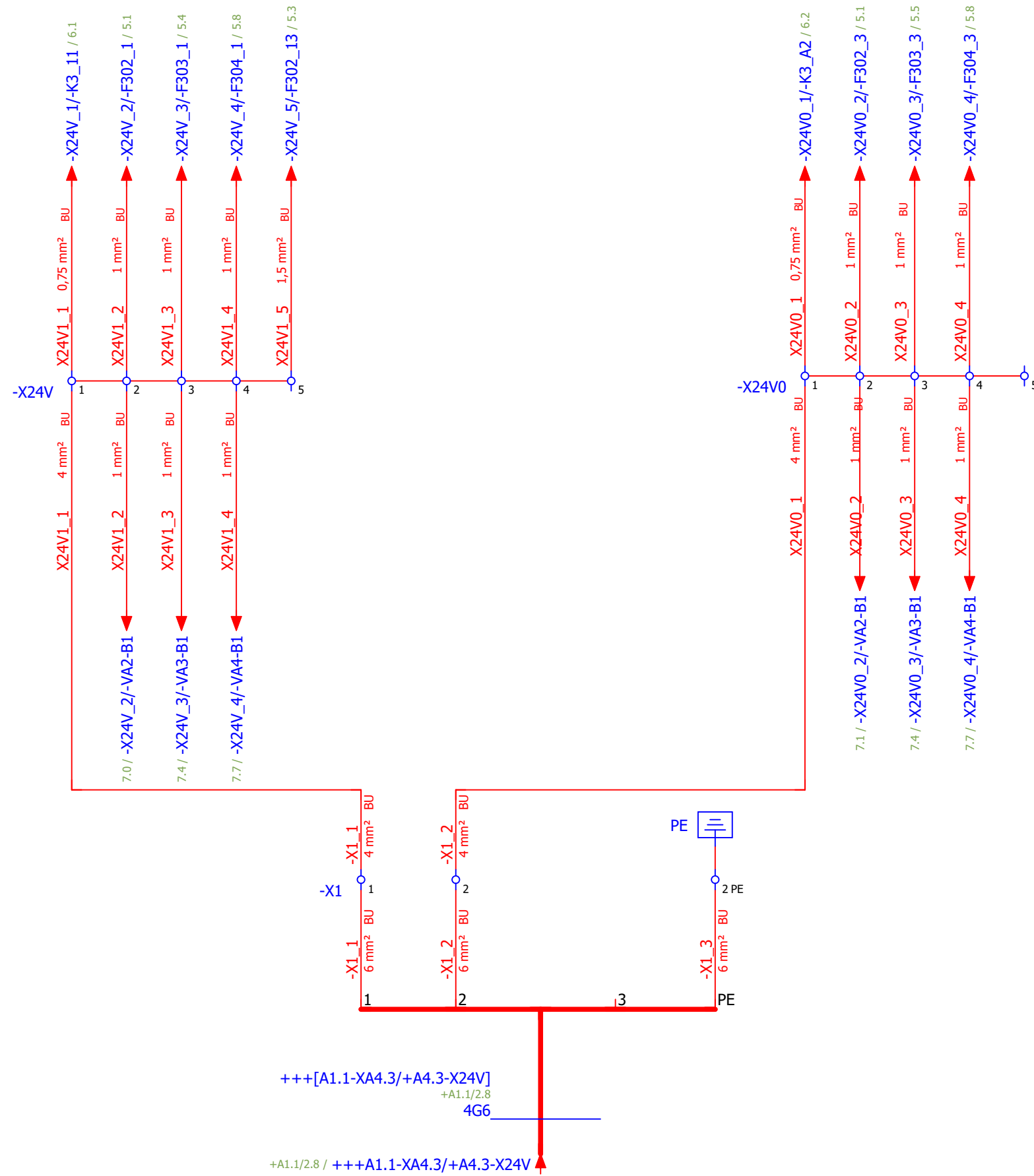
++	
+A4.3	

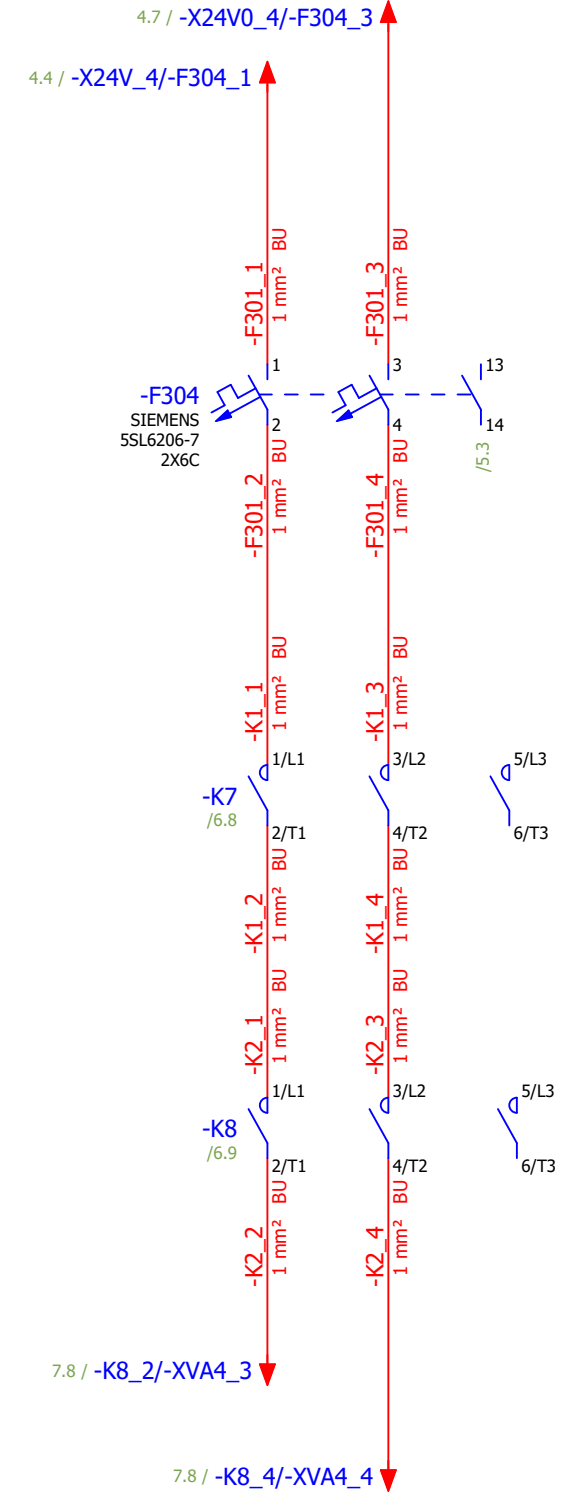
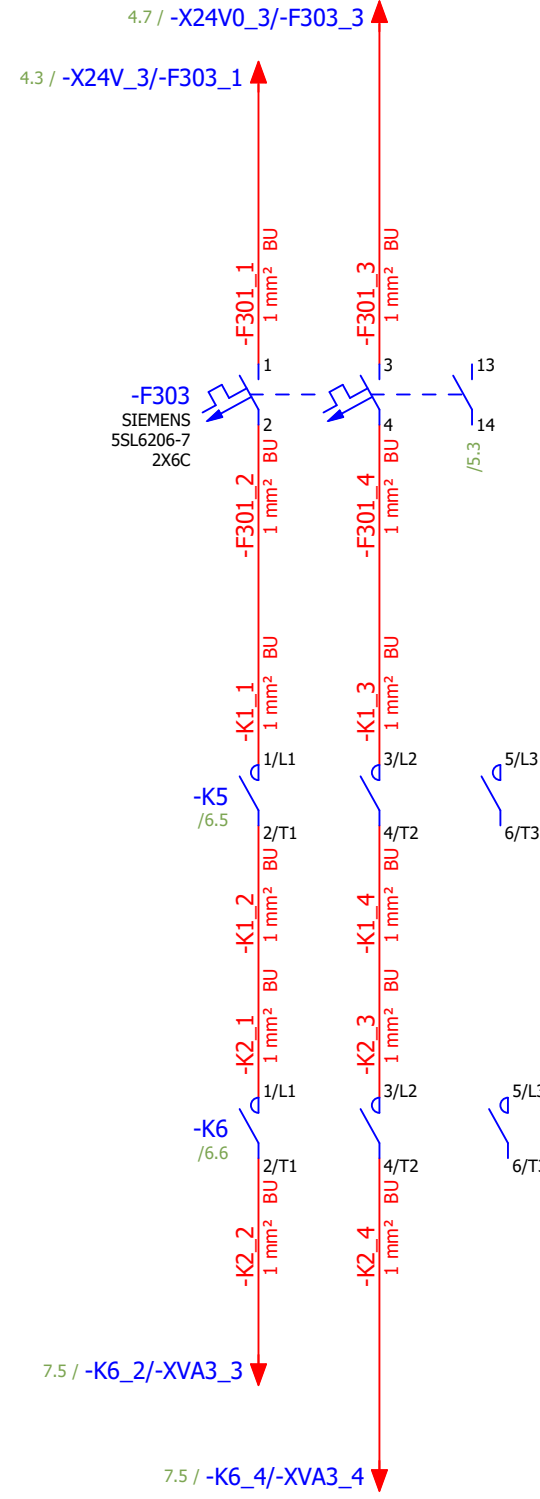
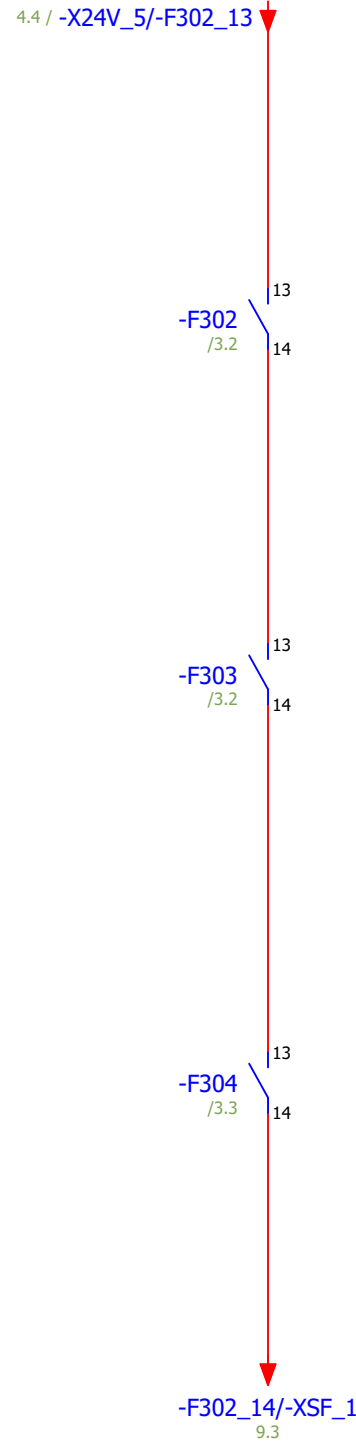
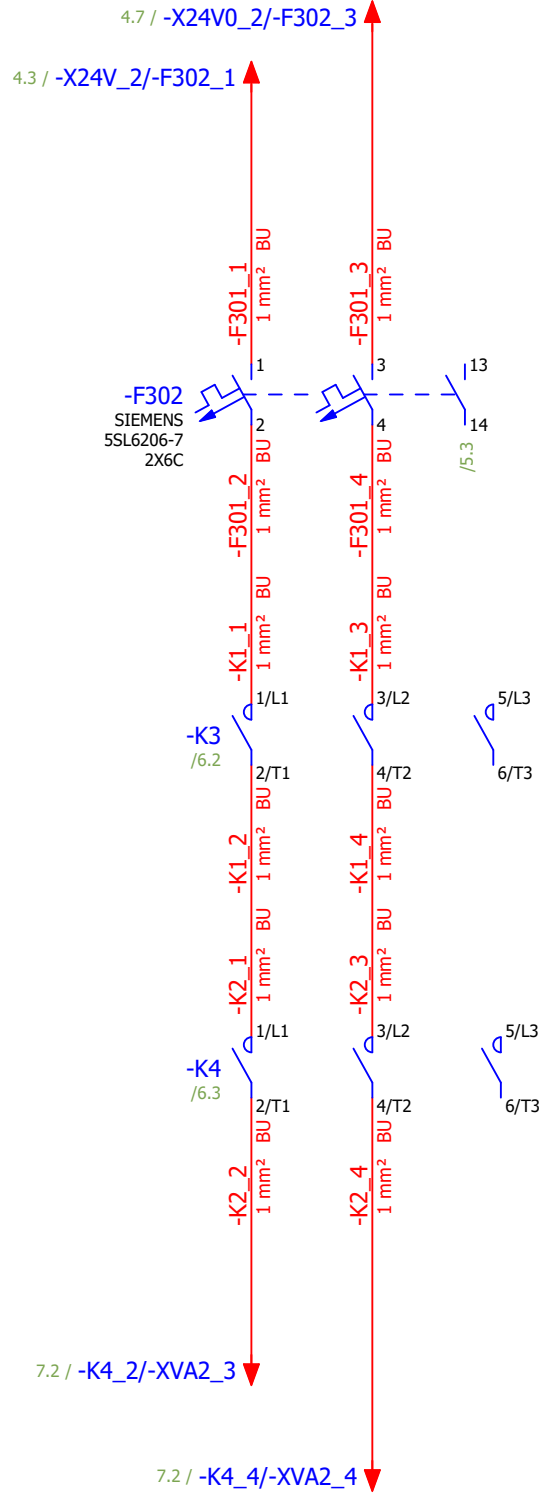



 <p>Yeşilyurt, Muhtar Cafer Sk. No:8 41190 Başiskele/Kocaeli</p> <p>info@dssotomasyon.com.tr</p> <p>+90 544 322 23 10</p>		<p><b>PROJE ADI</b></p> <p>PLC101 stoper</p>	<p><b>SAYFA AÇIKLAMASI</b></p> <p>24VDC SİGORTA</p>	<p>Çizen: Hasancan Simen</p> <p>Kontrol Eden: Sabri Ebrem</p>	<p>Sayfa 5</p> <p>++</p> <p>+A4.3</p>

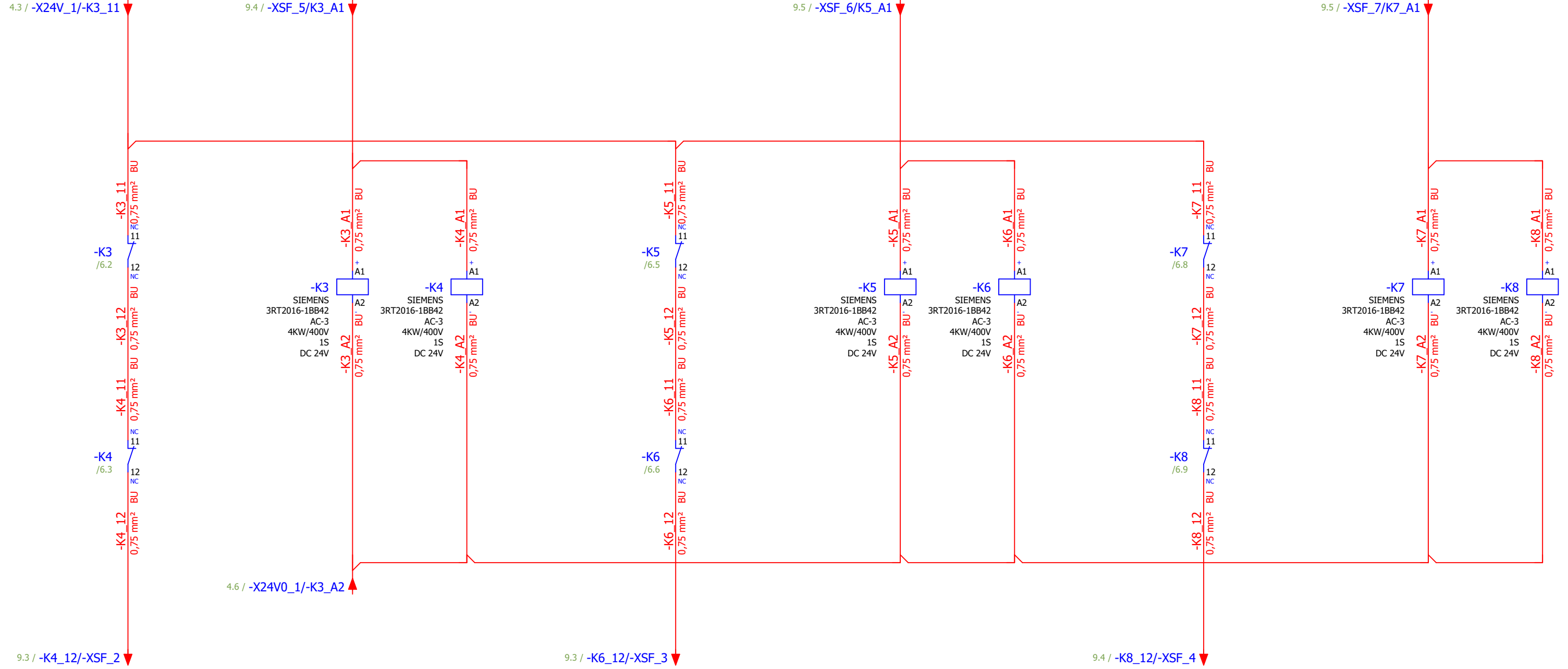

1/L1 2/T1 /5.1  
3/L2 4/T2 /5.1  
5/L3 6/T3 /5.1  
11 12 /6.1

1/L1 2/T1 /5.4  
3/L2 4/T2 /5.5  
5/L3 6/T3 /5.5  
11 12 /6.4

1/L1 2/T1 /5.8  
3/L2 4/T2 /5.8  
5/L3 6/T3 /5.8  
11 12 /6.7

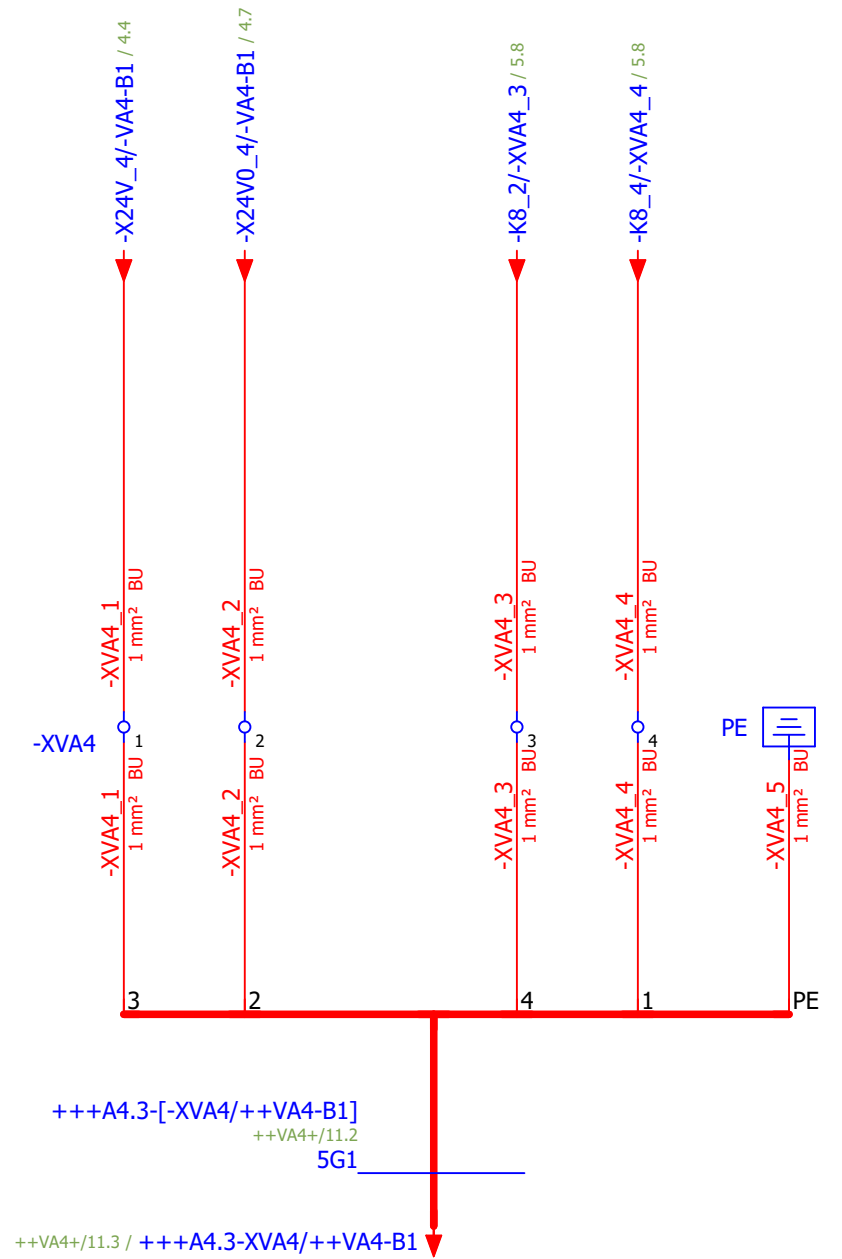
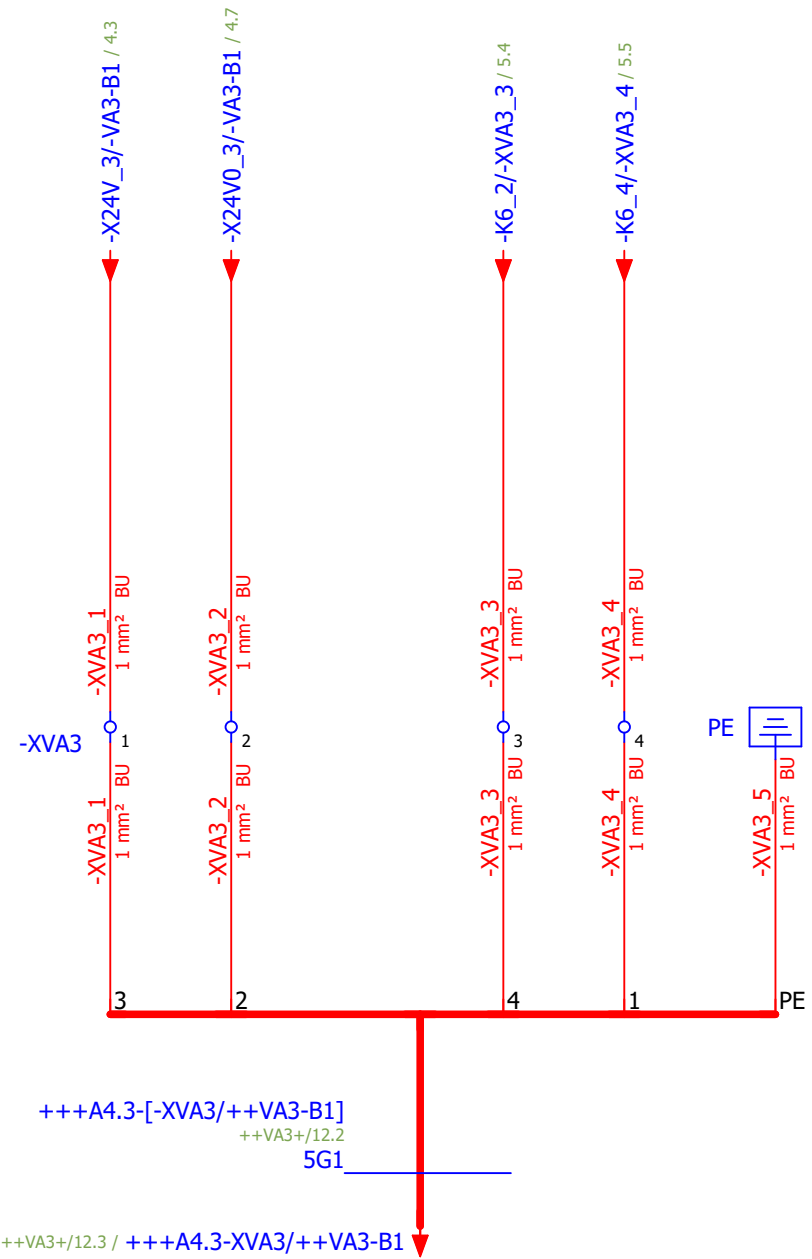
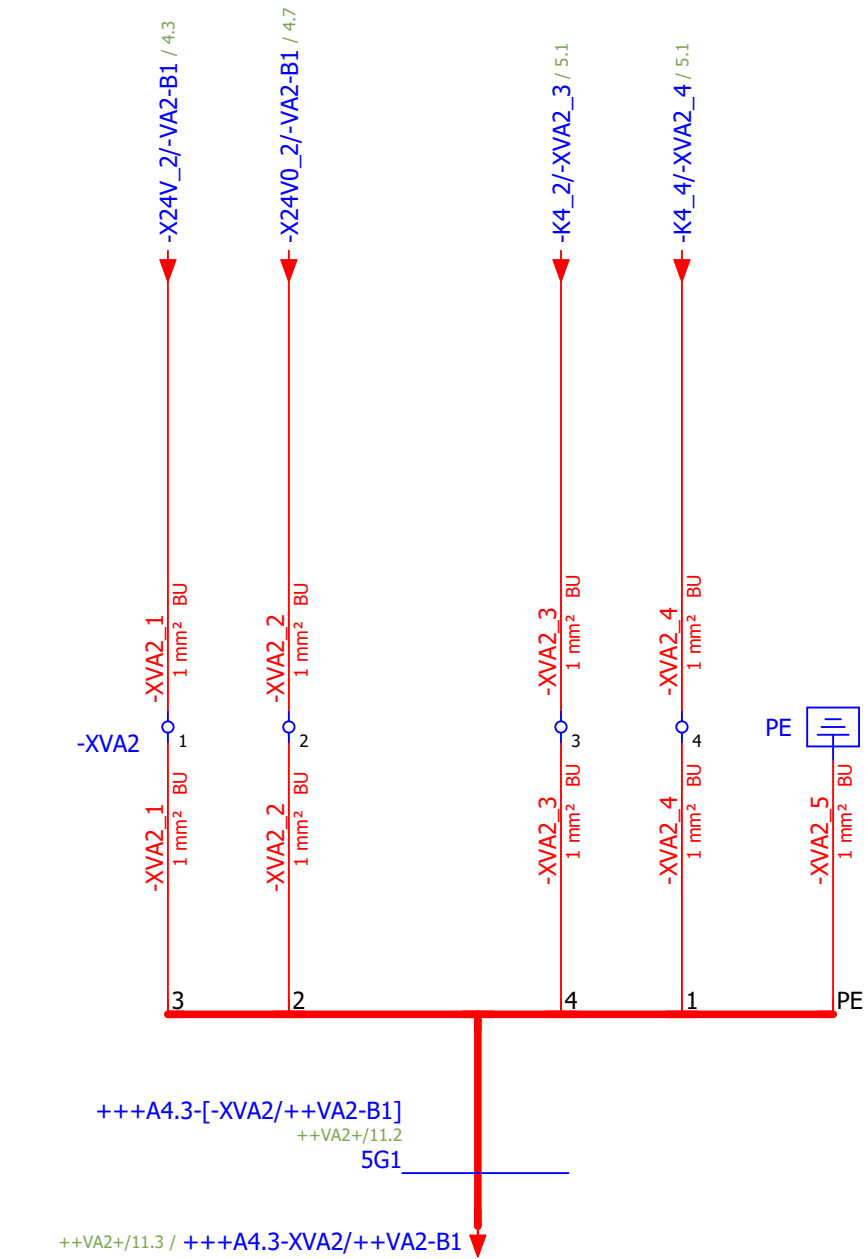

	Yeşilyurt, Muhtar Cafer Sk. No:8 41190 Başiskele/Kocaeli		<b>PROJE ADI</b>	<b>SAYFA AÇIKLAMASI</b>	Çizen: Hasancan Simen	Sayfa 7
	info@dssotomasyon.com.tr		PLC101 stoper	-VA 24VDC DAĞITIM	Kontrol Eden: Sabri Ebrem	++
	+90 544 322 23 10					+A4.3

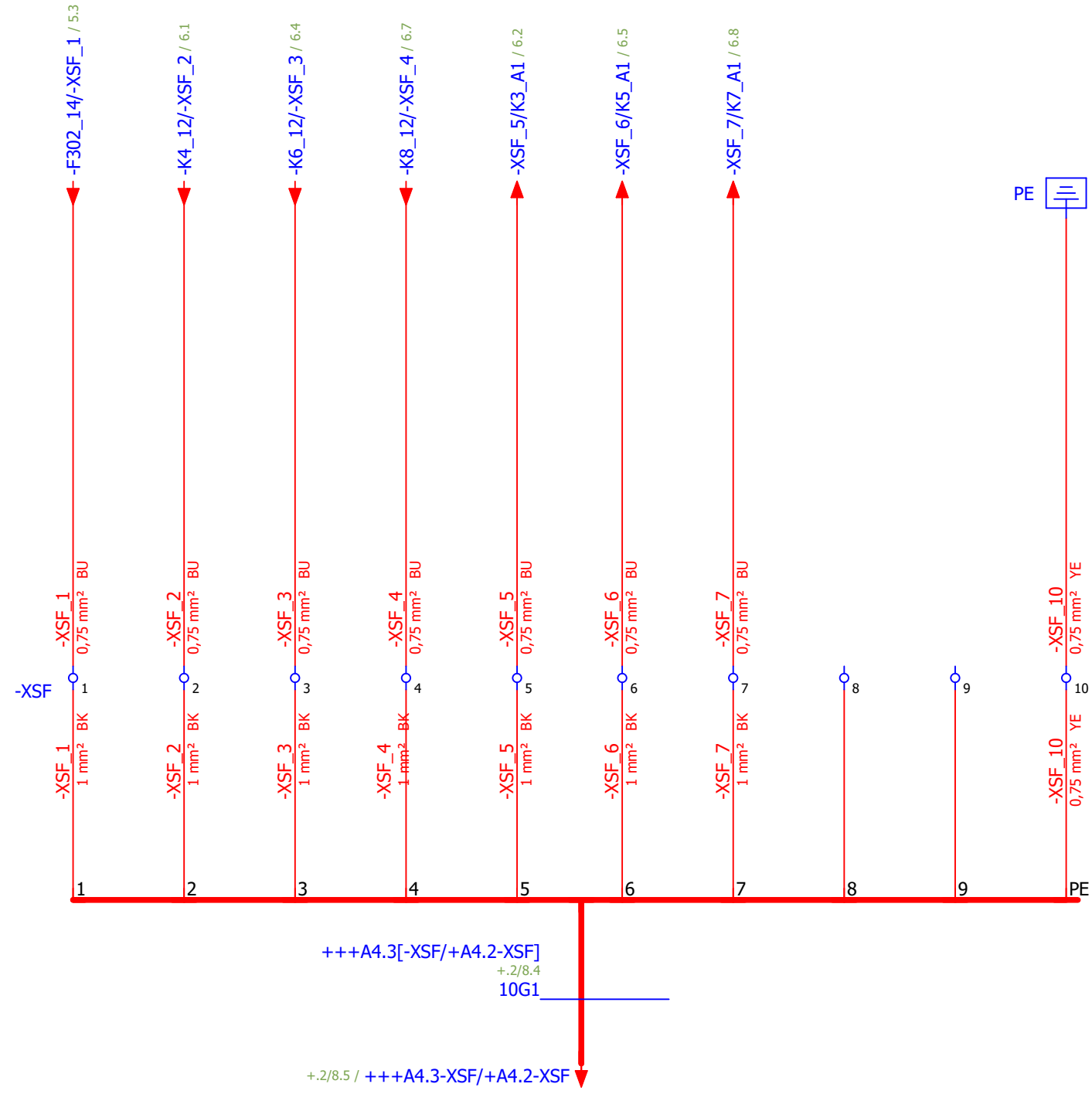

<b>PROJE ADI</b>	PLC101 stoper
------------------	---------------

<b>SAYFA AÇIKLAMASI</b>	I/O
-------------------------	-----

Çizen:	Hasancan Simen
Kontrol Eden:	Sabri Ebrem

++ +A4.3
-------------

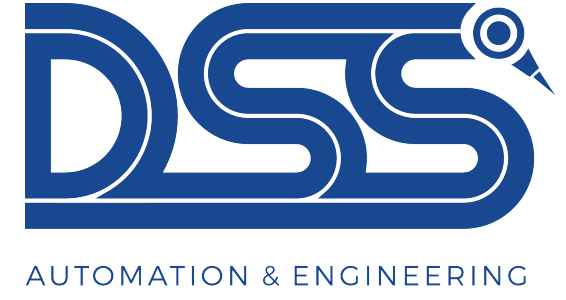

Müşteri : FORD OTOSAN

Üretici (şirket) : DSS OTOMASYON



++VA1

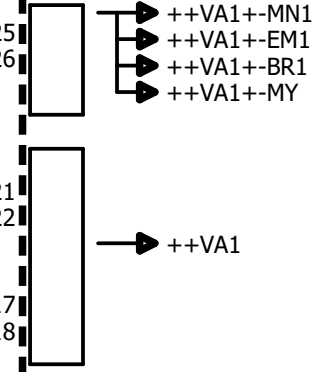
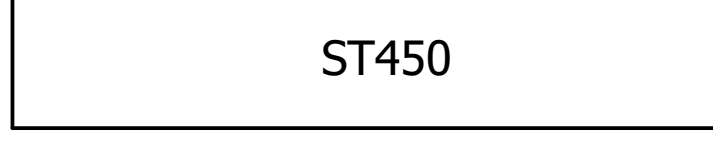
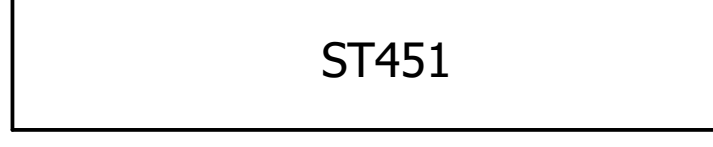
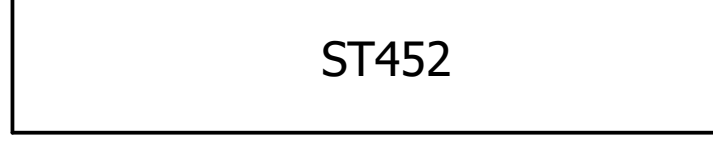
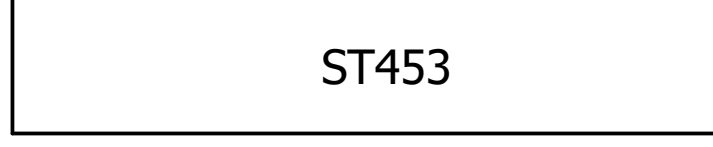
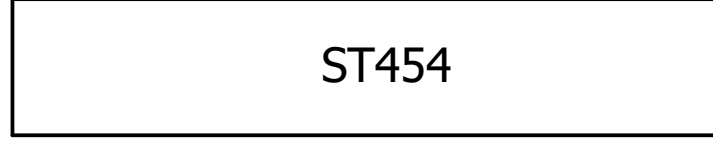
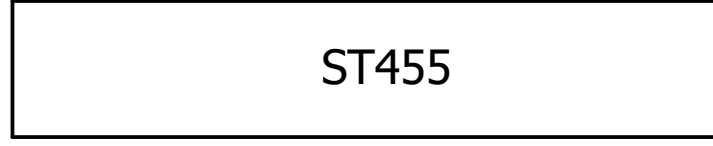
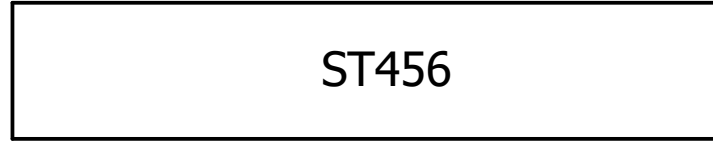
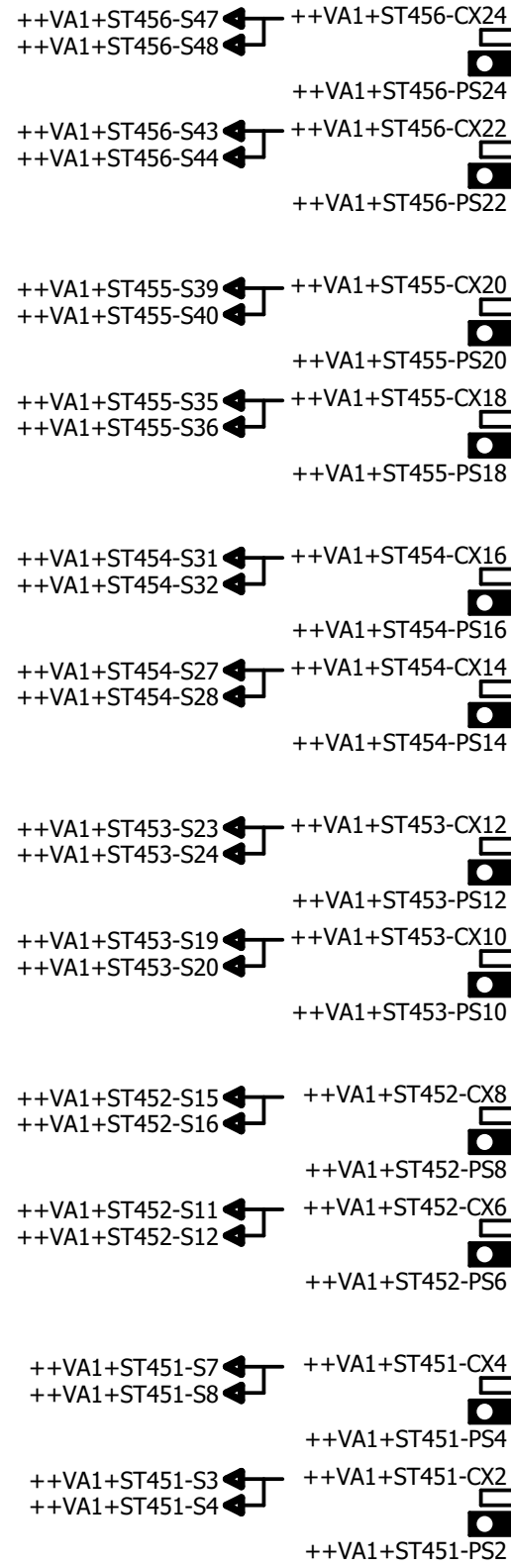

# KUZHEY

# GÜNEY



 AUTOMATION & ENGINEERING	Yeşilyurt, Muhtar Cafer Sk. No:8 41190 Başiskele/Kocaeli		<b>PROJE ADI</b>	<b>SAYFA AÇIKLAMASI</b>	Çizen: Hasancan Simen	Sayfa 2
	info@dssotomasyon.com.tr		PLC101 stoper	LAYOUT	Kontrol Eden: Sabri Ebrem	++VA1 +
+90 544 322 23 10						

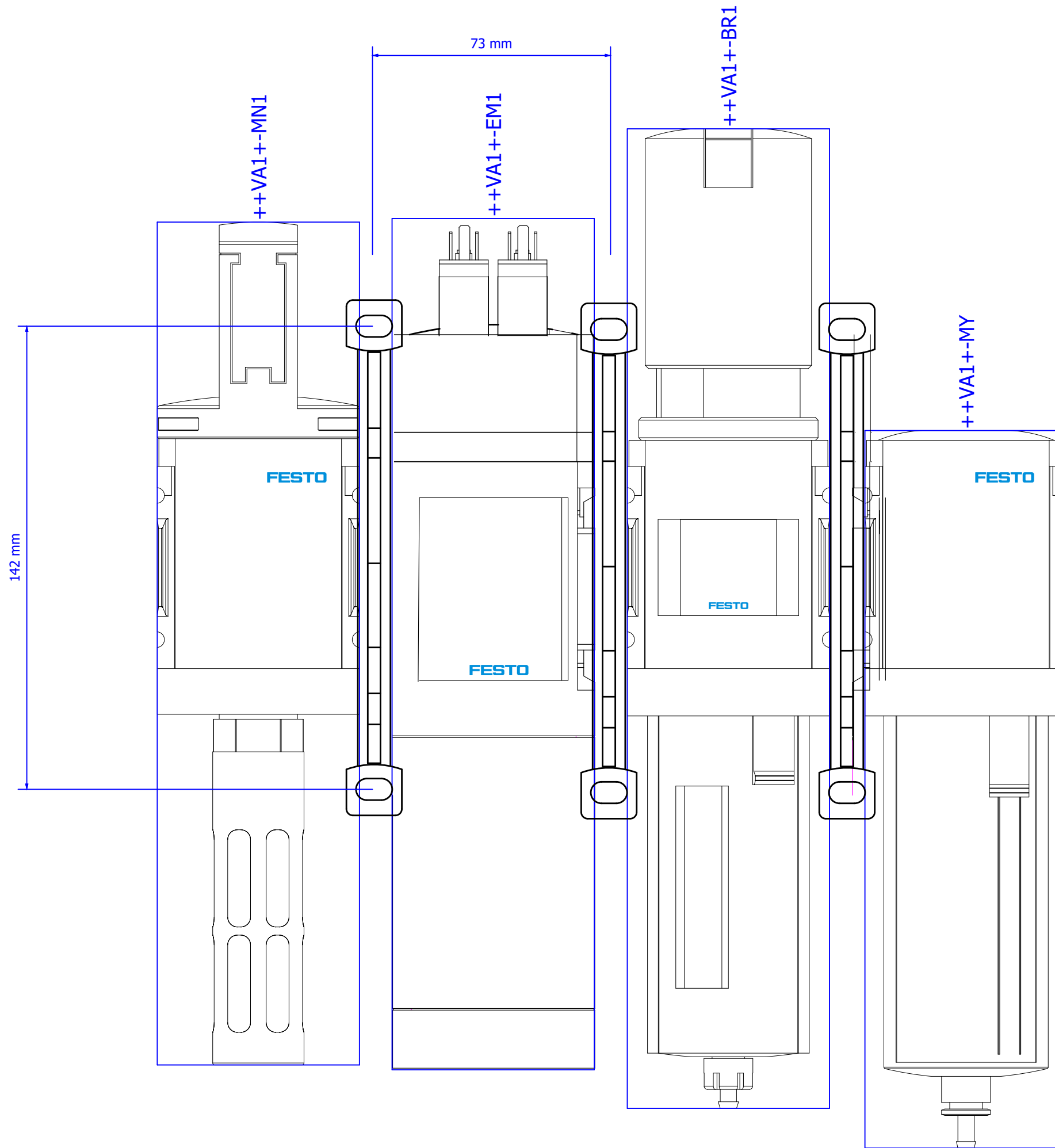



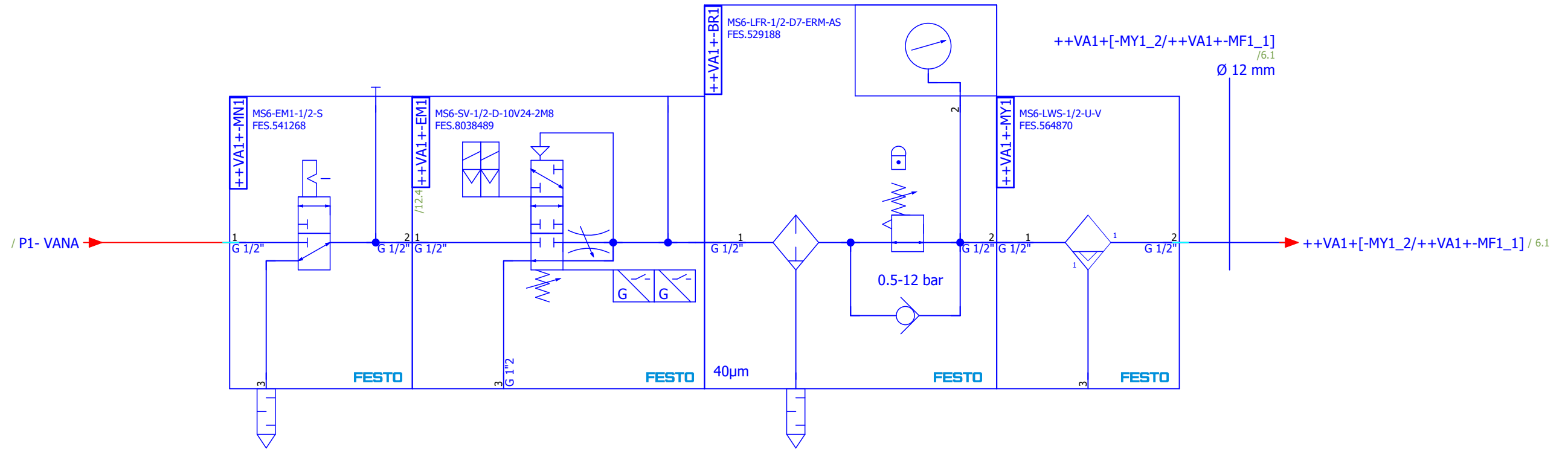



5.a

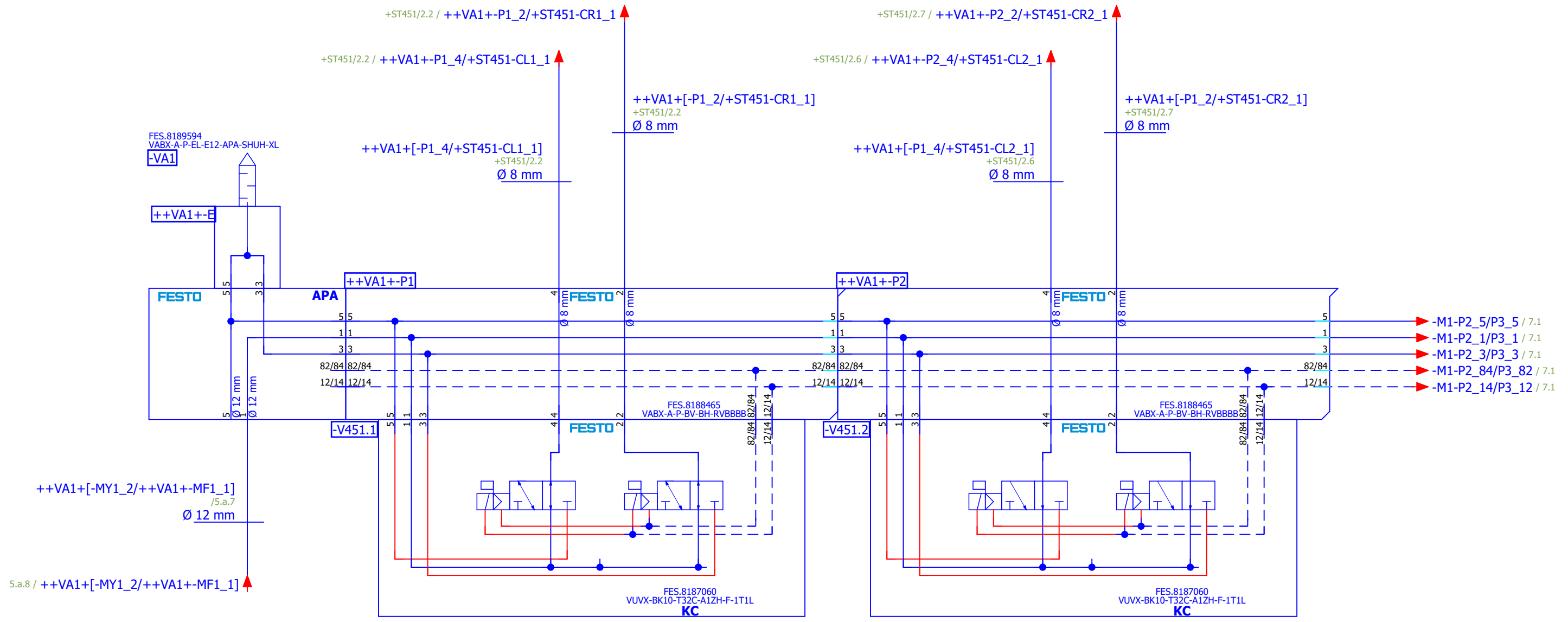

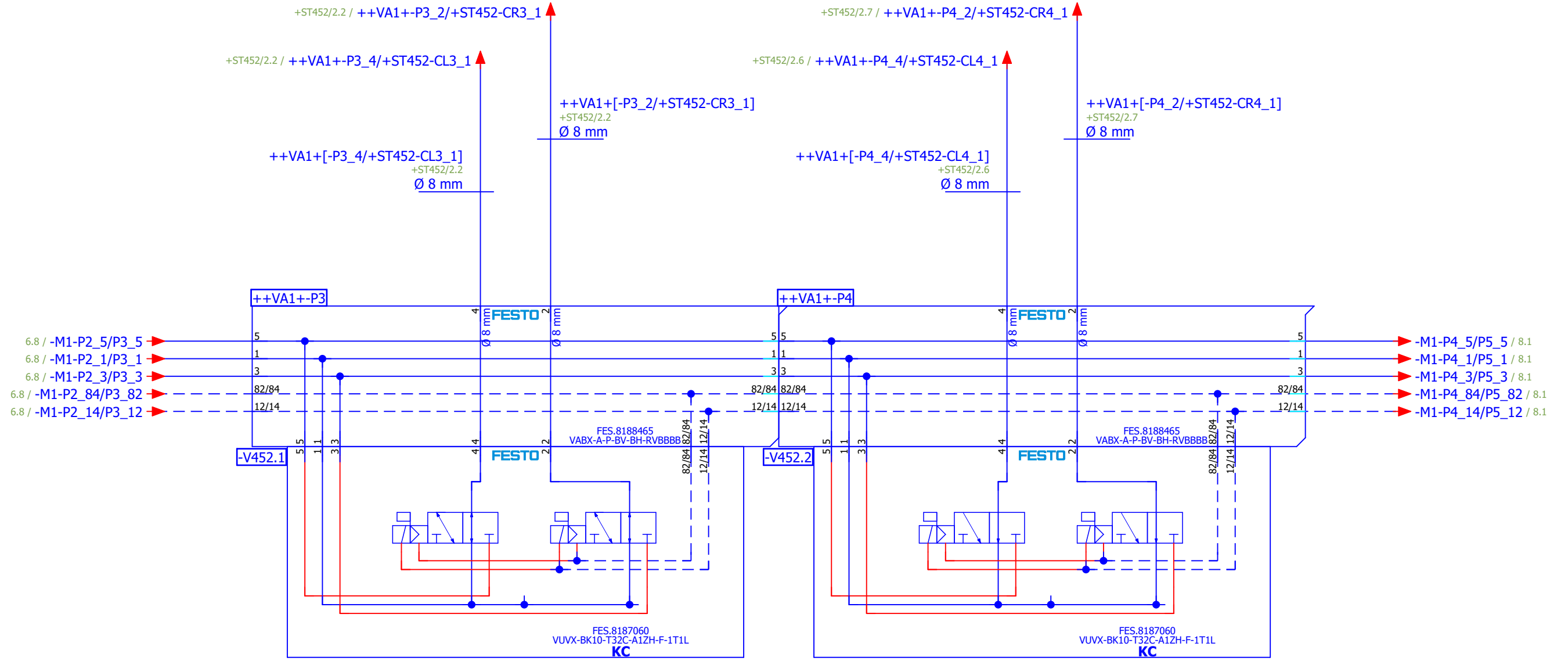

- -M1-P2\_5/P3\_5 / 7.1
- -M1-P2\_1/P3\_1 / 7.1
- -M1-P2\_3/P3\_3 / 7.1
- -M1-P2\_84/P3\_82 / 7.1
- -M1-P2\_14/P3\_12 / 7.1



	Yeşilyurt, Muhtar Cafer Sk. No:8 41190 Başiskele/Kocaeli		<b>PROJE ADI</b>	<b>SAYFA AÇIKLAMASI</b>	Çizen: Hasancan Simen	Sayfa 7
	info@dssotomasyon.com.tr		PLC101 stoper	-VA1-V452	Kontrol Eden: Sabri Ebrem	
	+90 544 322 23 10					

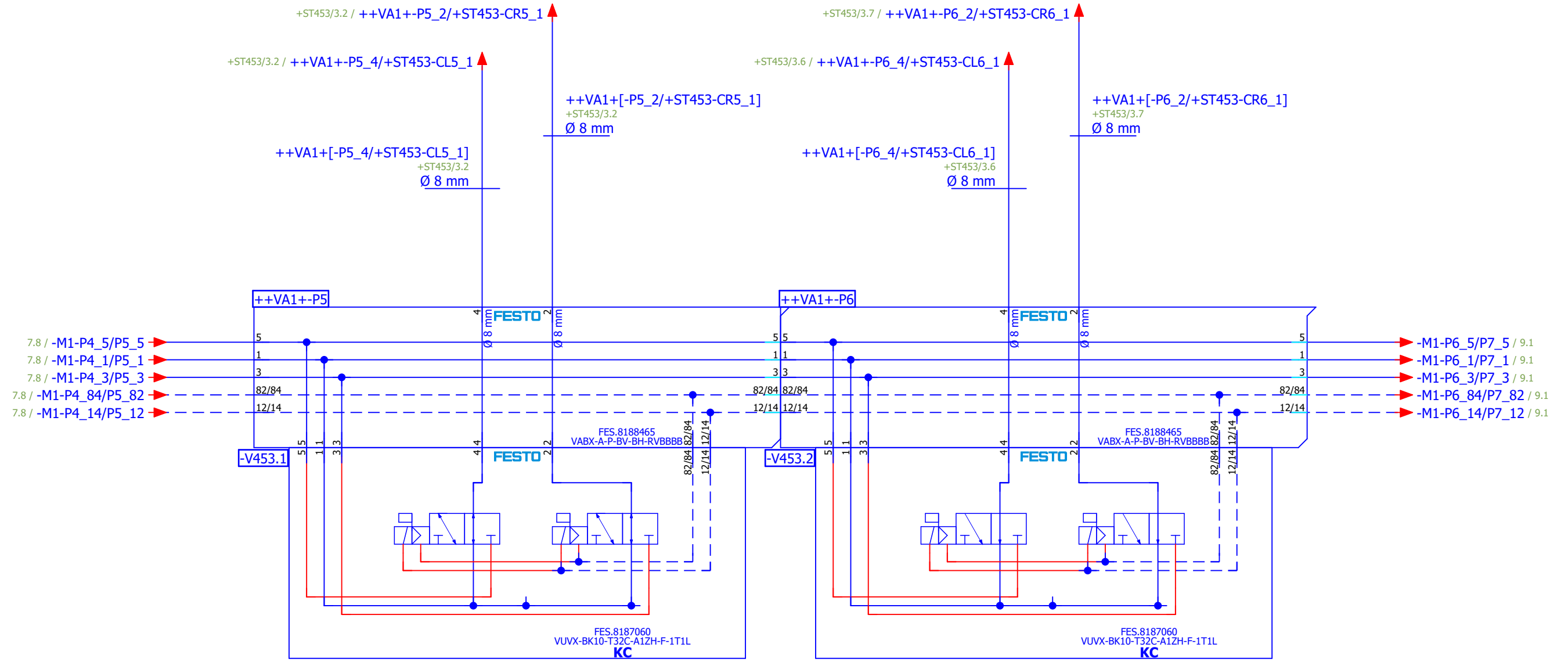

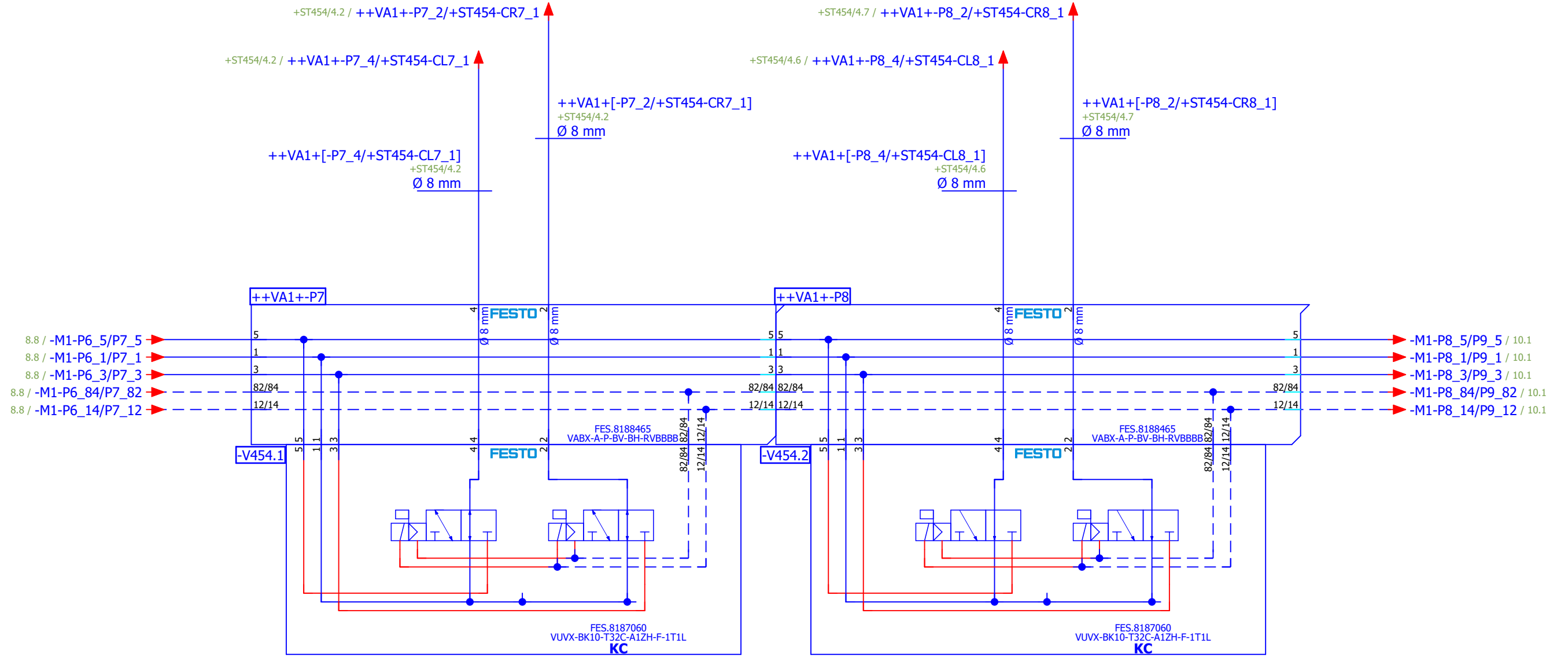

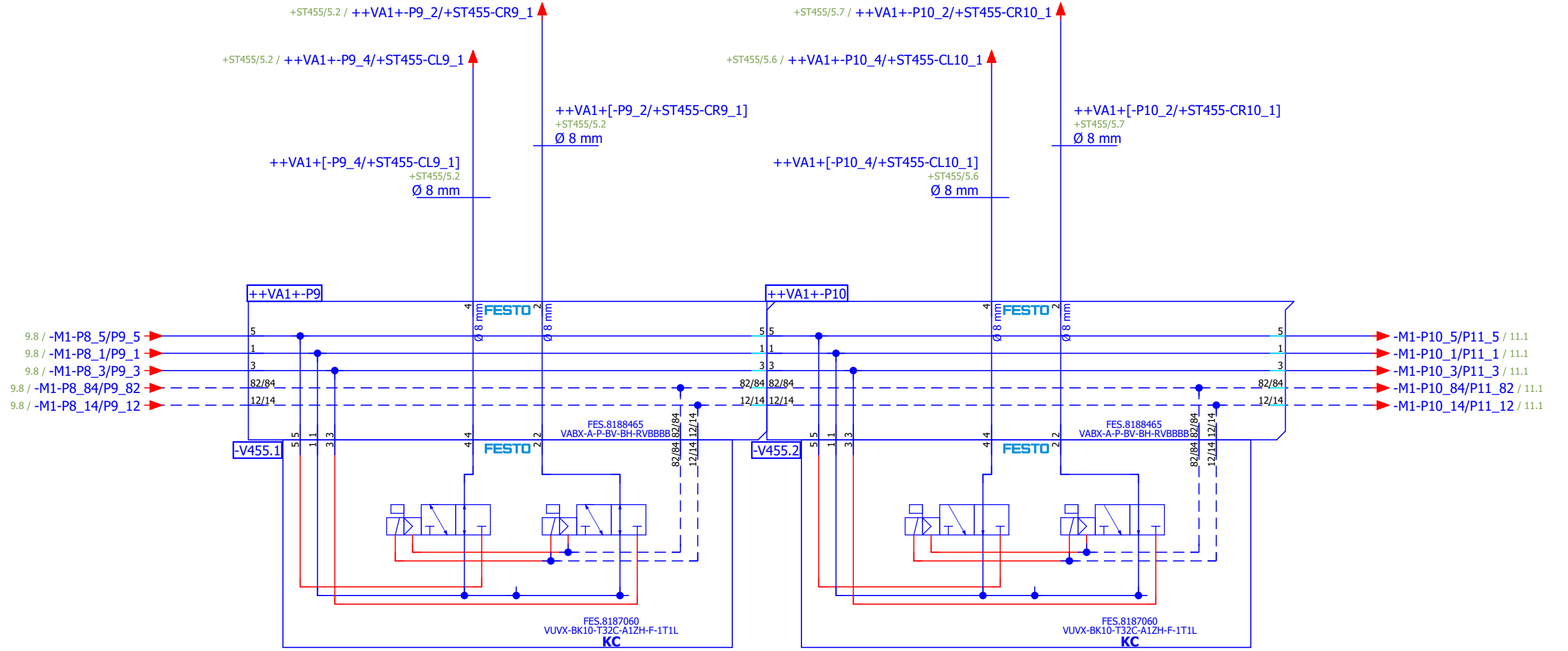

	Yeşilyurt, Muhtar Cafer Sk. No:8 41190 Başiskele/Kocaeli		<b>PROJE ADI</b>	<b>SAYFA AÇIKLAMASI</b>	Çizen: Hasancan Simen	Sayfa 10
	info@dssotomasyon.com.tr		PLC101 stoper	-VA1-V455	Kontrol Eden: Sabri Ebrem	++VA1
	+90 544 322 23 10					+

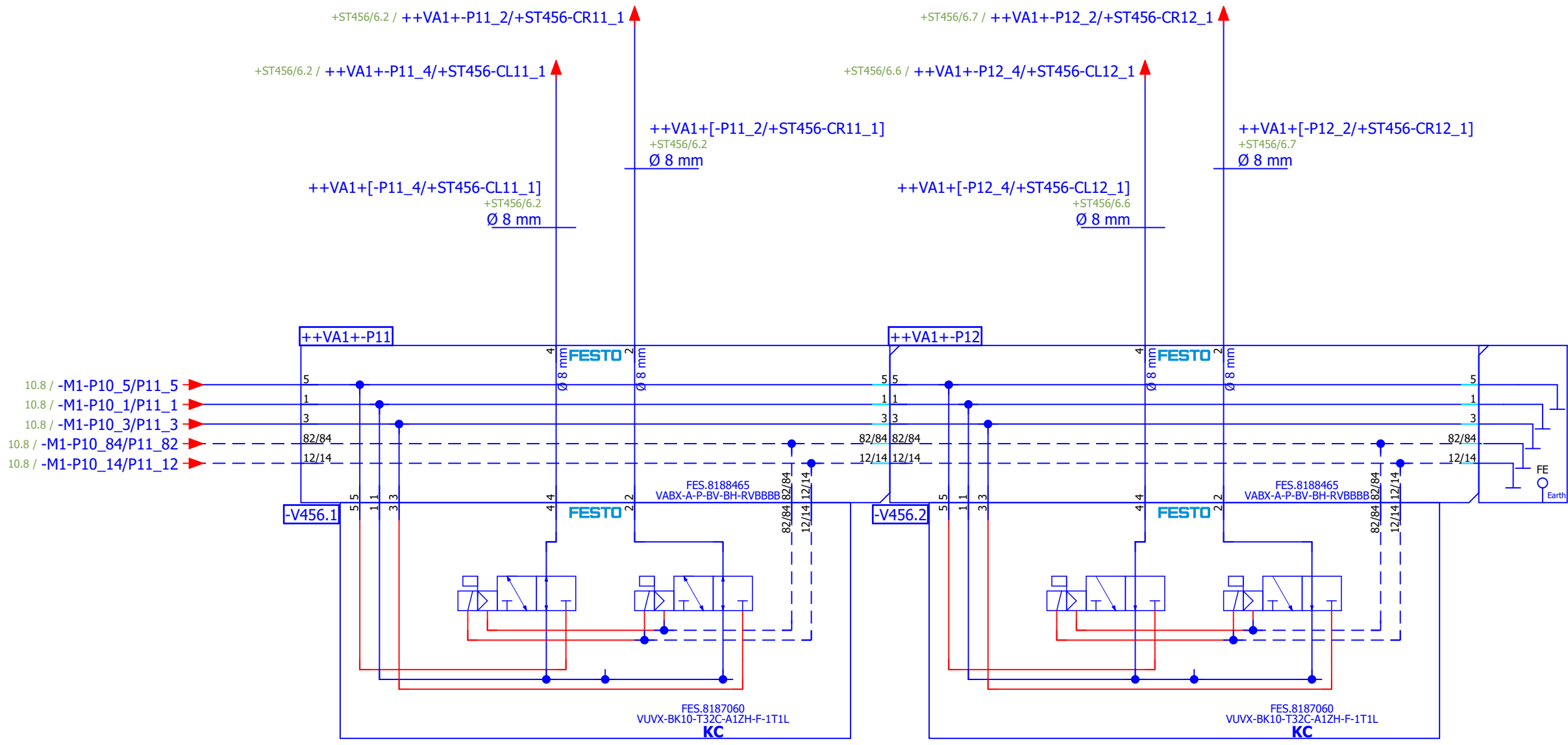

<p>Yeşilyurt, Muhtar Cafer Sk. No:8 41190 Başiskele/Kocaeli</p> <p>info@dssotomasyon.com.tr</p> <p>+90 544 322 23 10</p>		<p><b>PROJE ADI</b></p> <p>PLC101 stoper</p>	<p><b>SAYFA AÇIKLAMASI</b></p> <p>-VA1-V456</p>	<p>Çizen: Hasancan Simen</p> <p>Kontrol Eden: Sabri Ebrem</p>	<p>Sayfa 11</p> <p>T. Sayfa 38 / 167</p>
		<p><b>++VA1</b></p>	<p><b>+</b></p>		

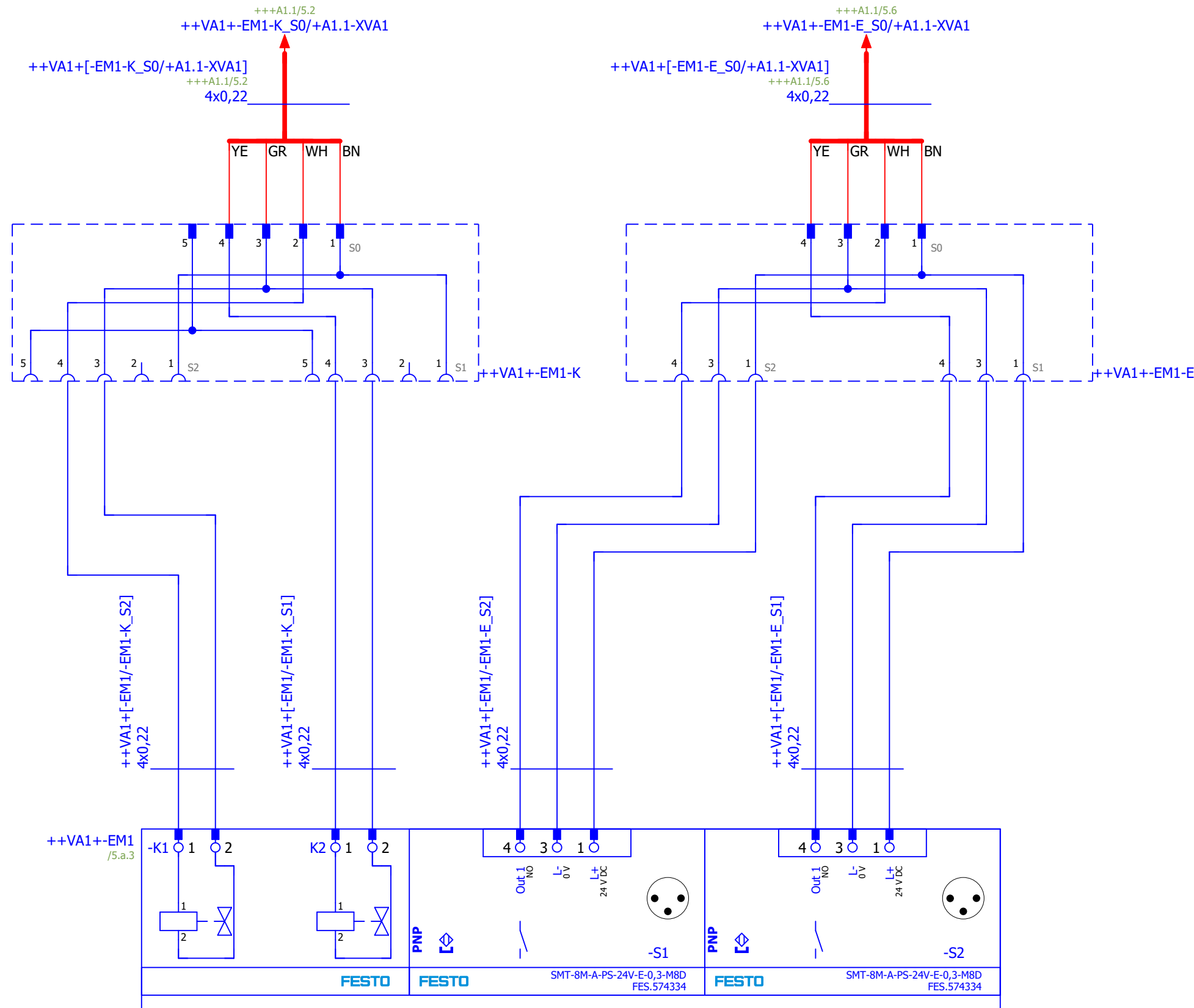
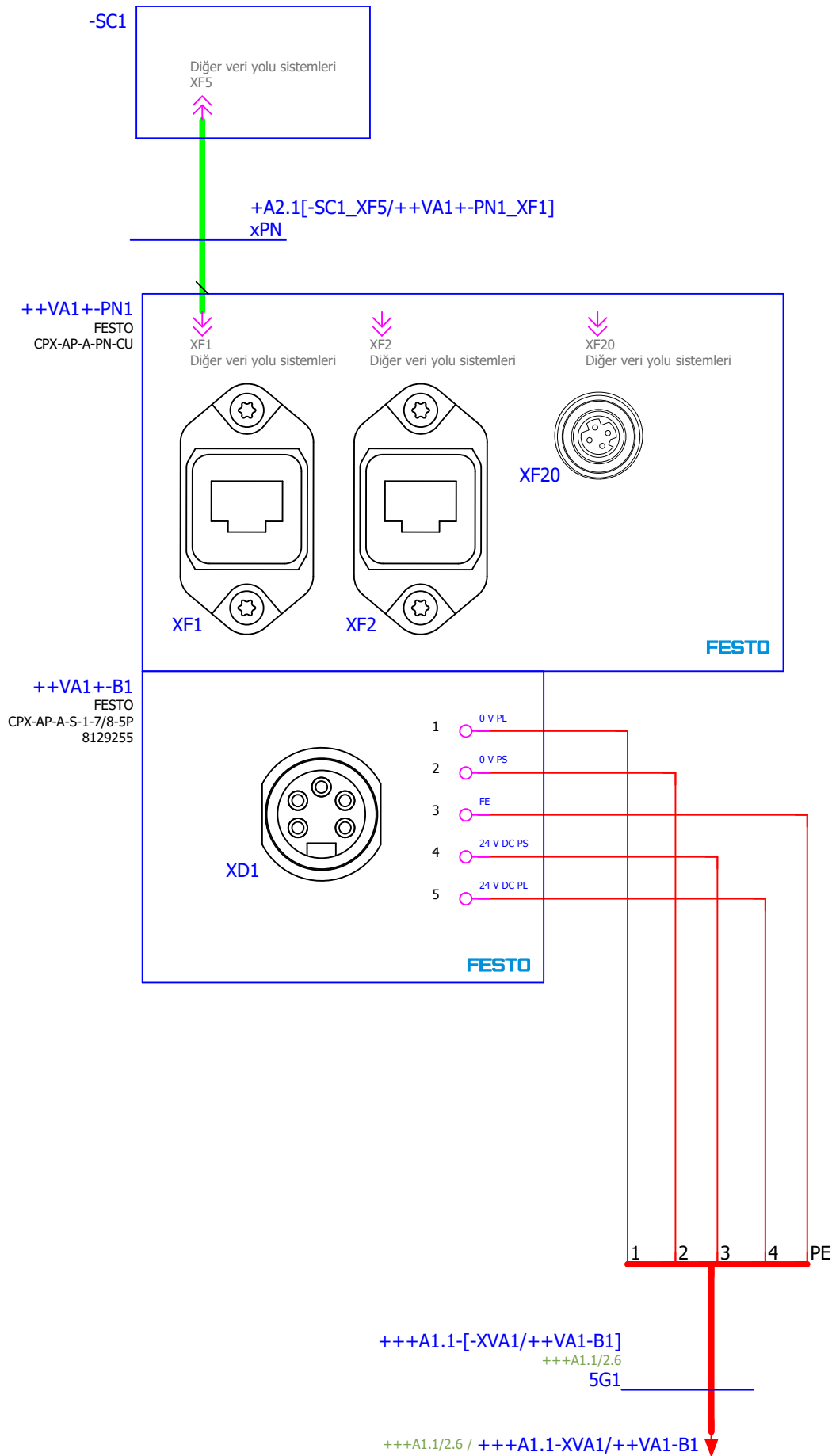

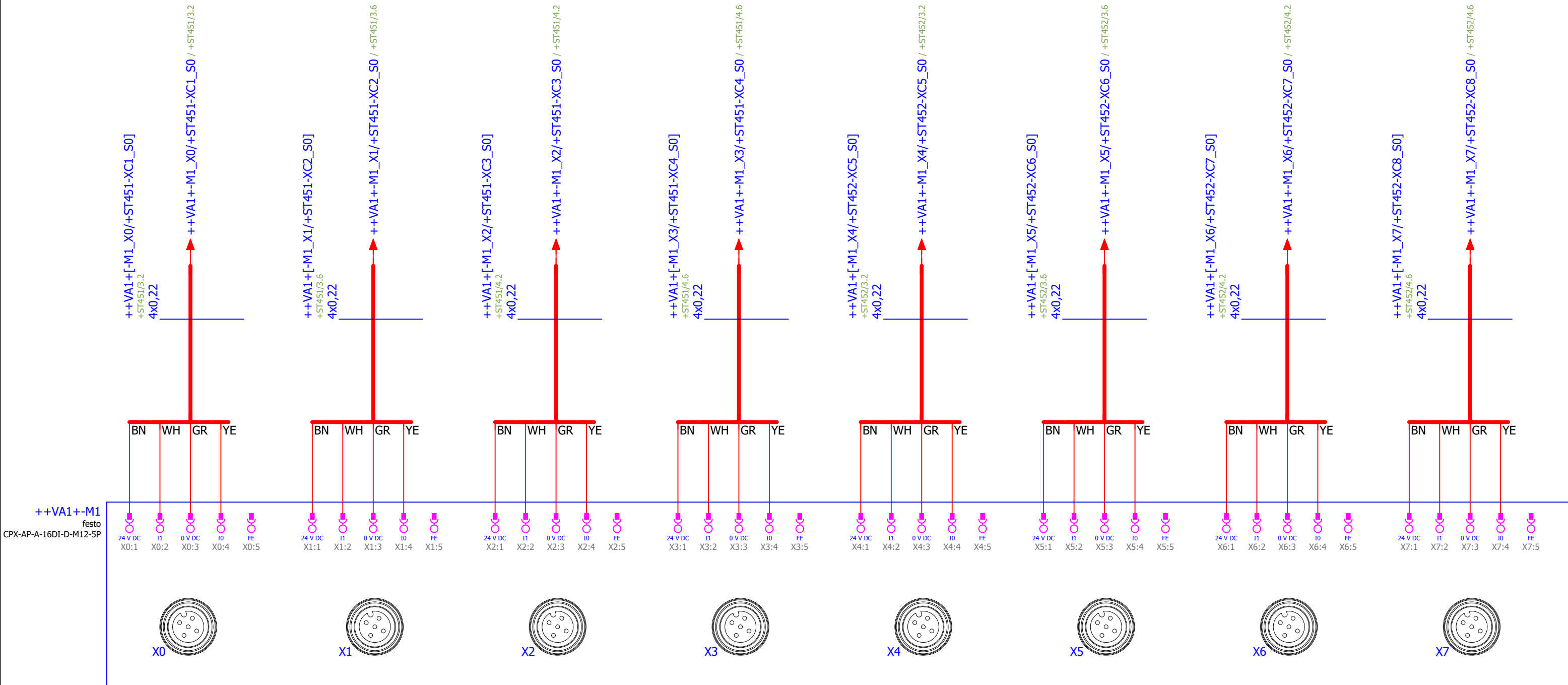

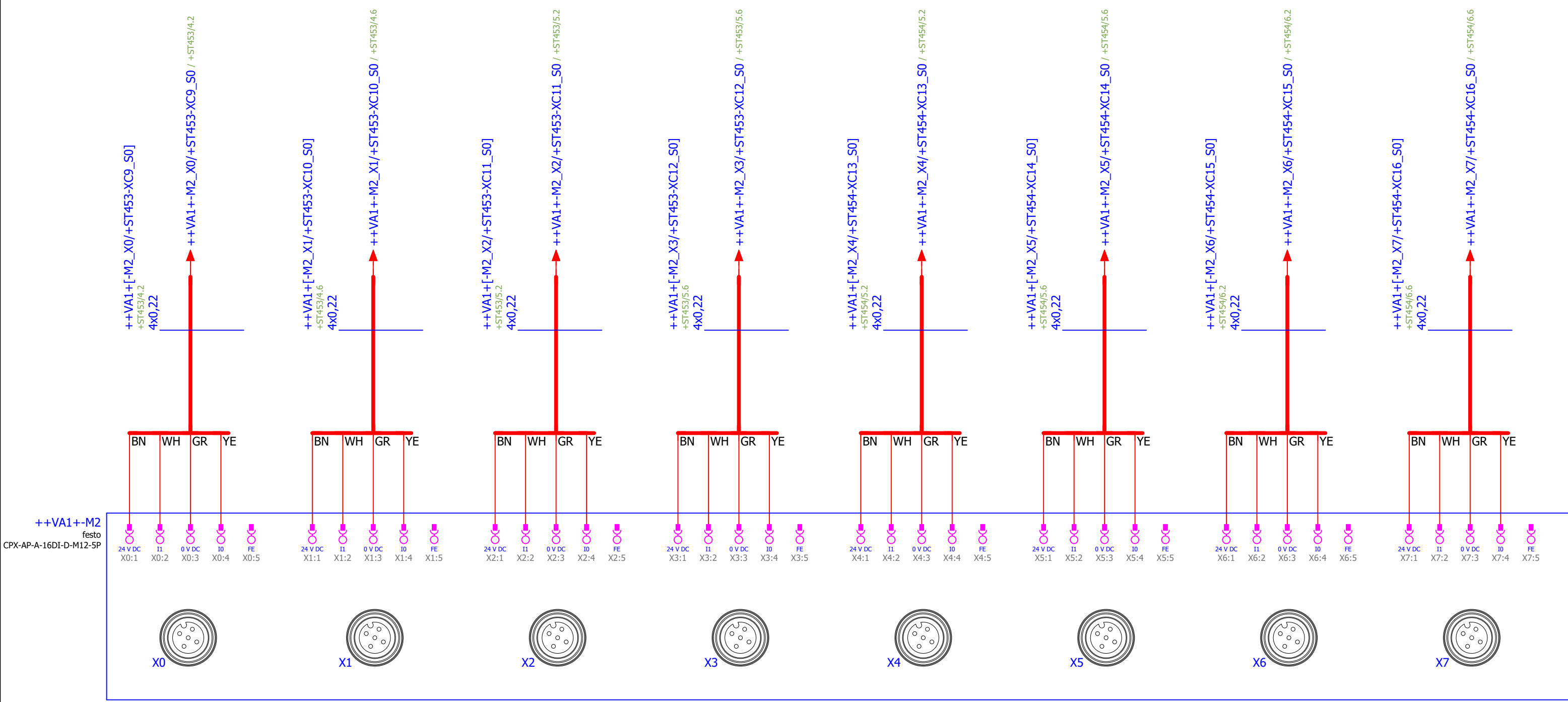

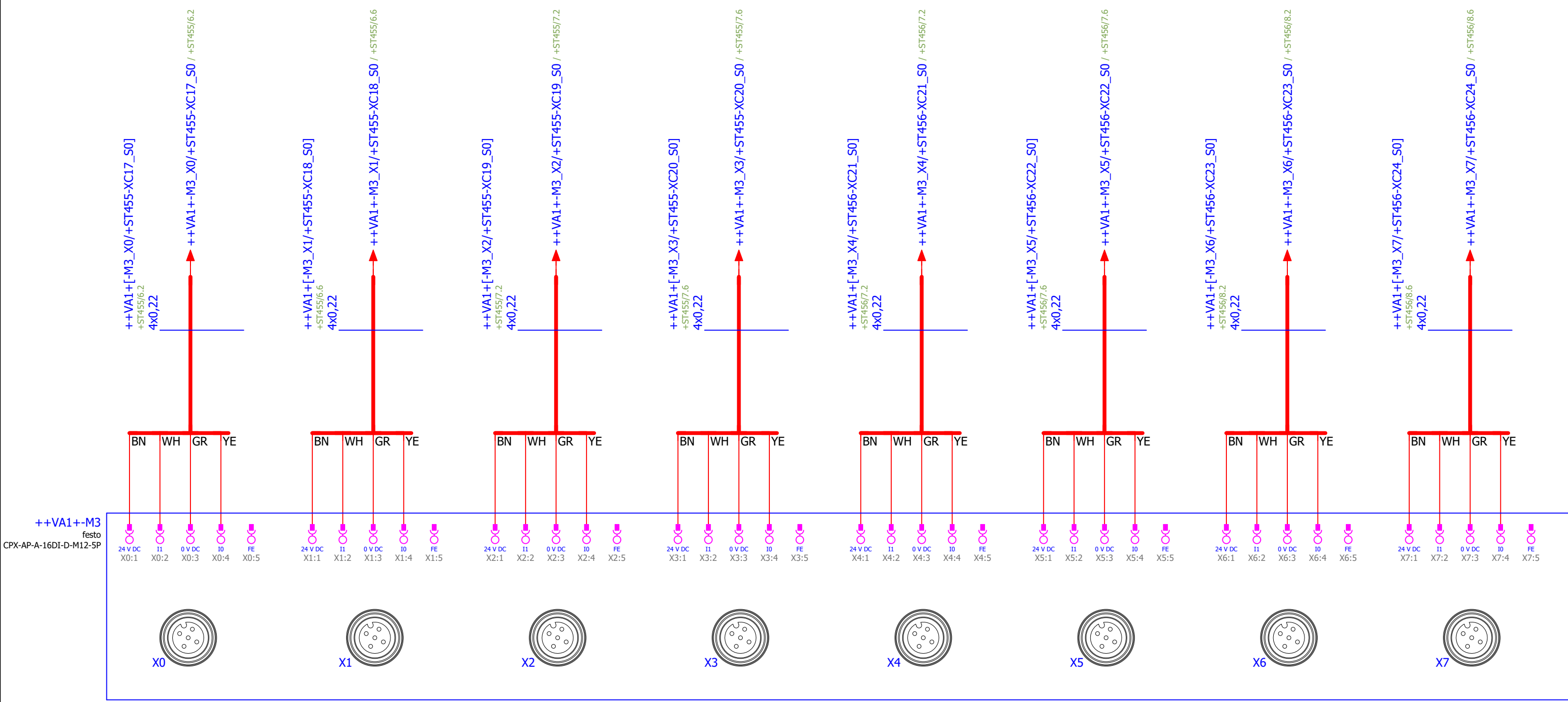

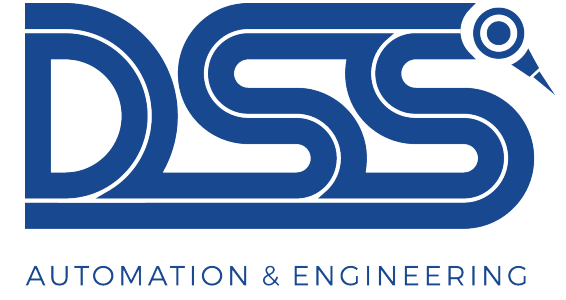

Müşteri : FORD OTOSAN

Üretici (şirket) : DSS OTOMASYON



+ST451

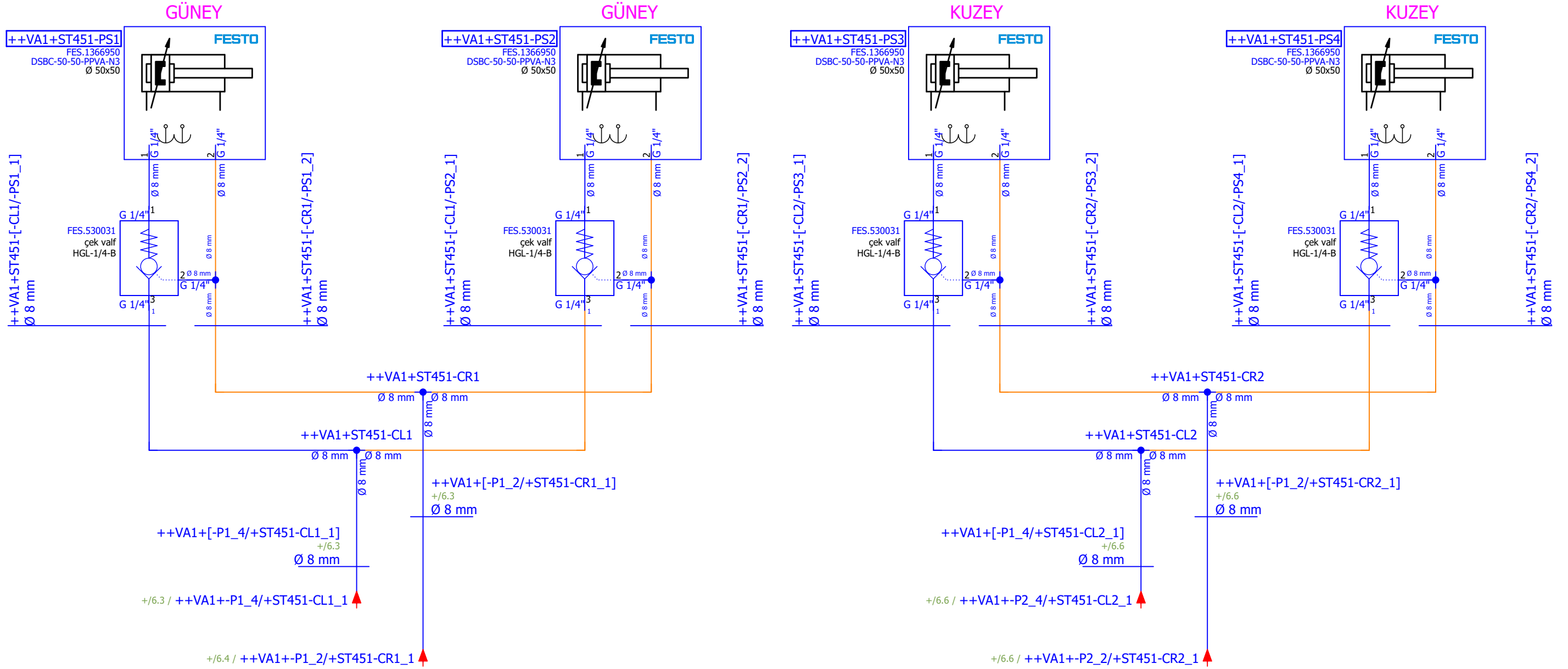

1

	Yeşilyurt, Muhtar Cafer Sk. No:8 41190 Başiskele/Kocaeli		<b>PROJE ADI</b>	<b>SAYFA AÇIKLAMASI</b>	Çizen: Hasancan Simen	Sayfa 1
	info@dssotomasyon.com.tr		PLC101 stoper	KAPAK	Kontrol Eden: Sabri Ebrem	++VA1
	+90 544 322 23 10					+ST451



 <p>Yeşilyurt, Muhtar Cafer Sk. No:8 41190 Başiskele/Kocaeli</p> <p>info@dssotomasyon.com.tr</p> <p>+90 544 322 23 10</p>		<p><b>PROJE ADI</b></p> <p>PLC101 stoper</p>	<p><b>SAYFA AÇIKLAMASI</b></p> <p>PİSTONLAR</p>	<p>Çizen: Hasancan Simen</p> <p>Kontrol Eden: Sabri Ebrem</p>	<p>Sayfa 2</p> <p>T. Sayfa 44 / 167</p>
		<p><b>++VA1</b></p> <p><b>+ST451</b></p>			



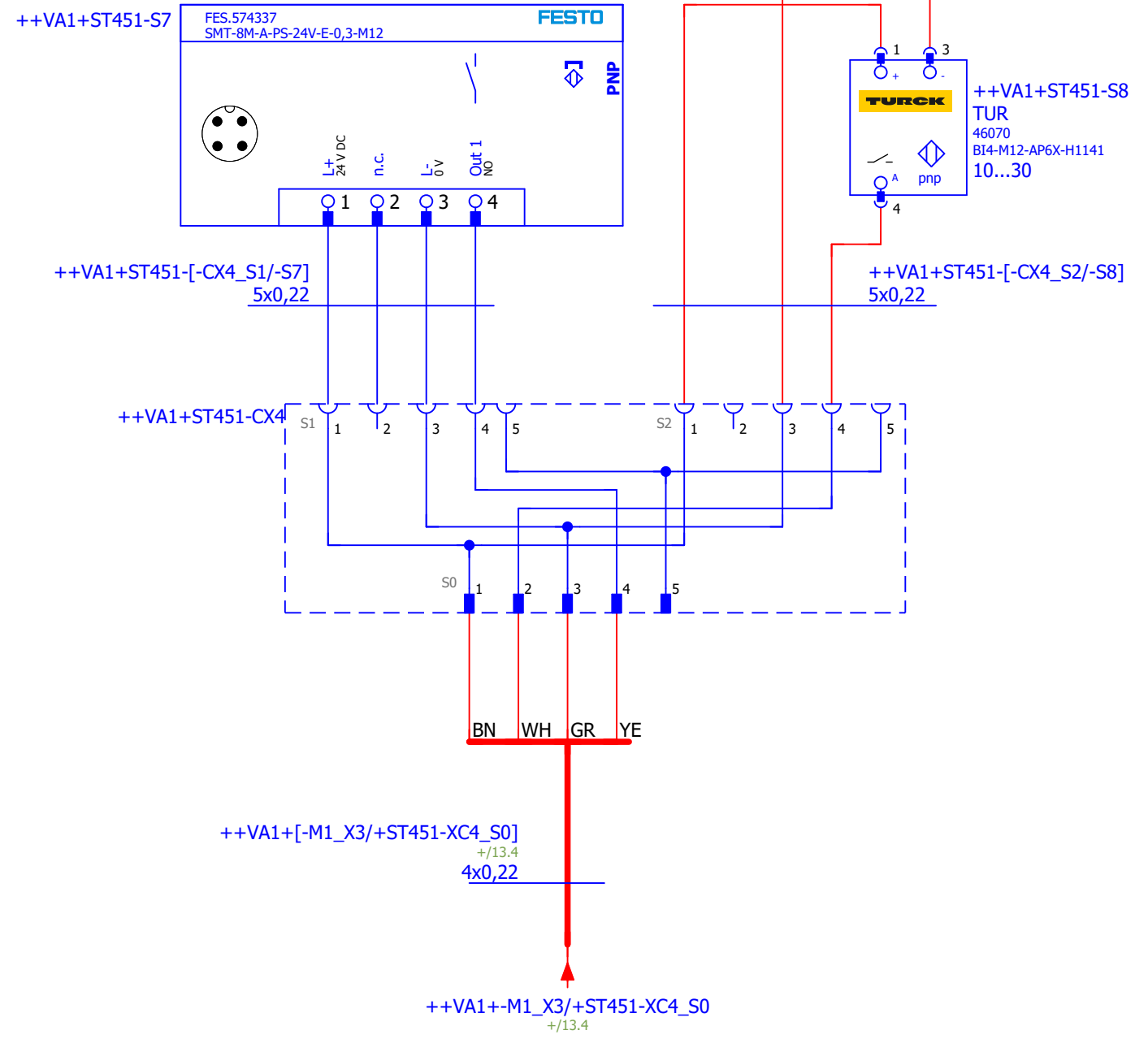
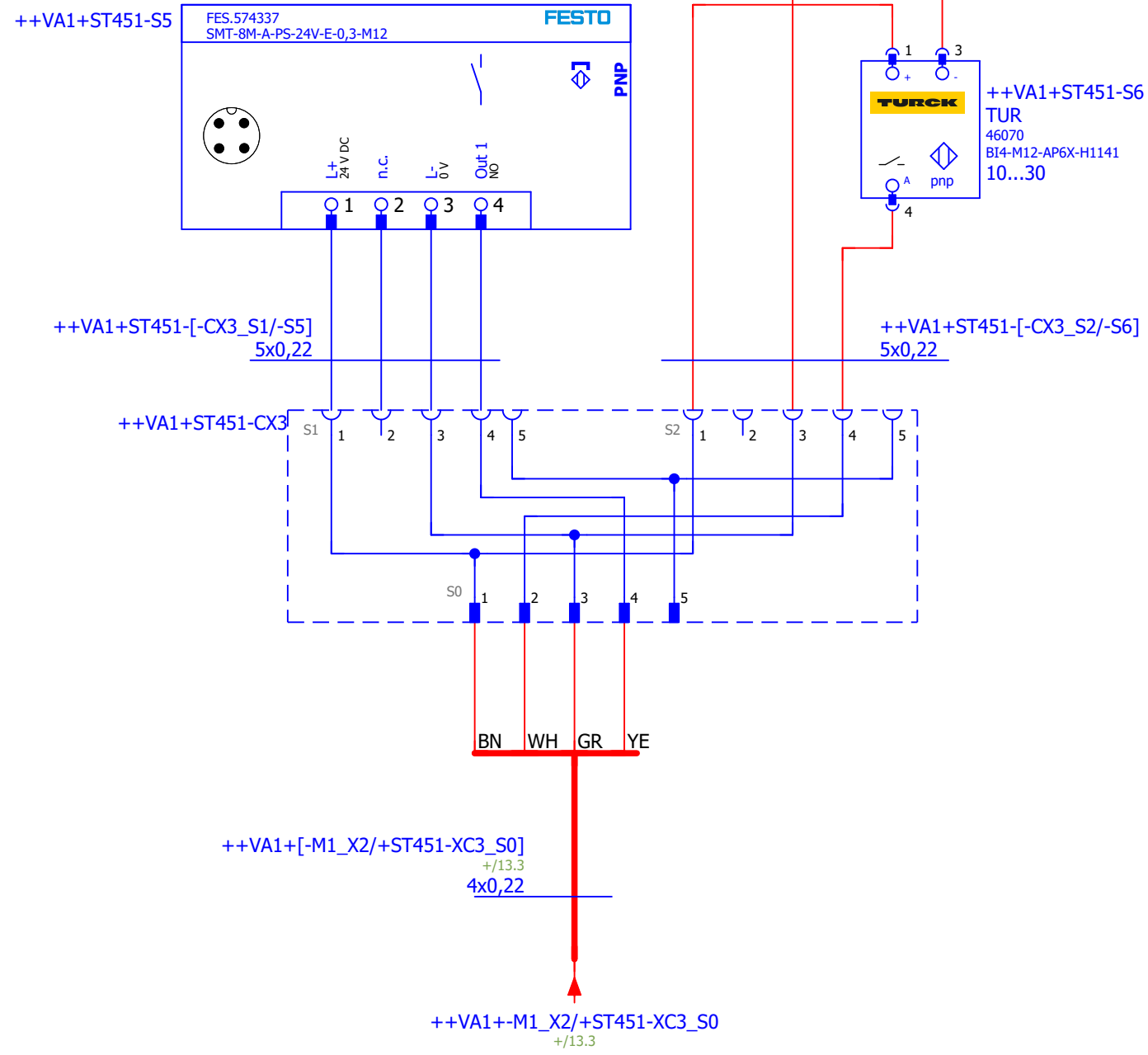

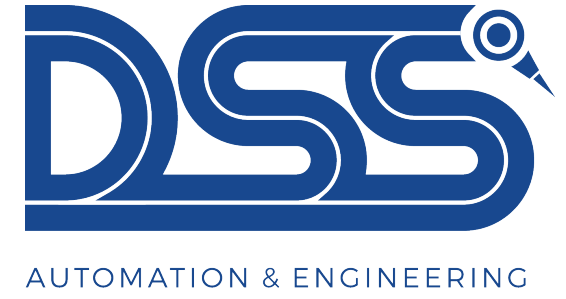

Müşteri : FORD OTOSAN



Üretici (şirket) : DSS OTOMASYON

+ST452

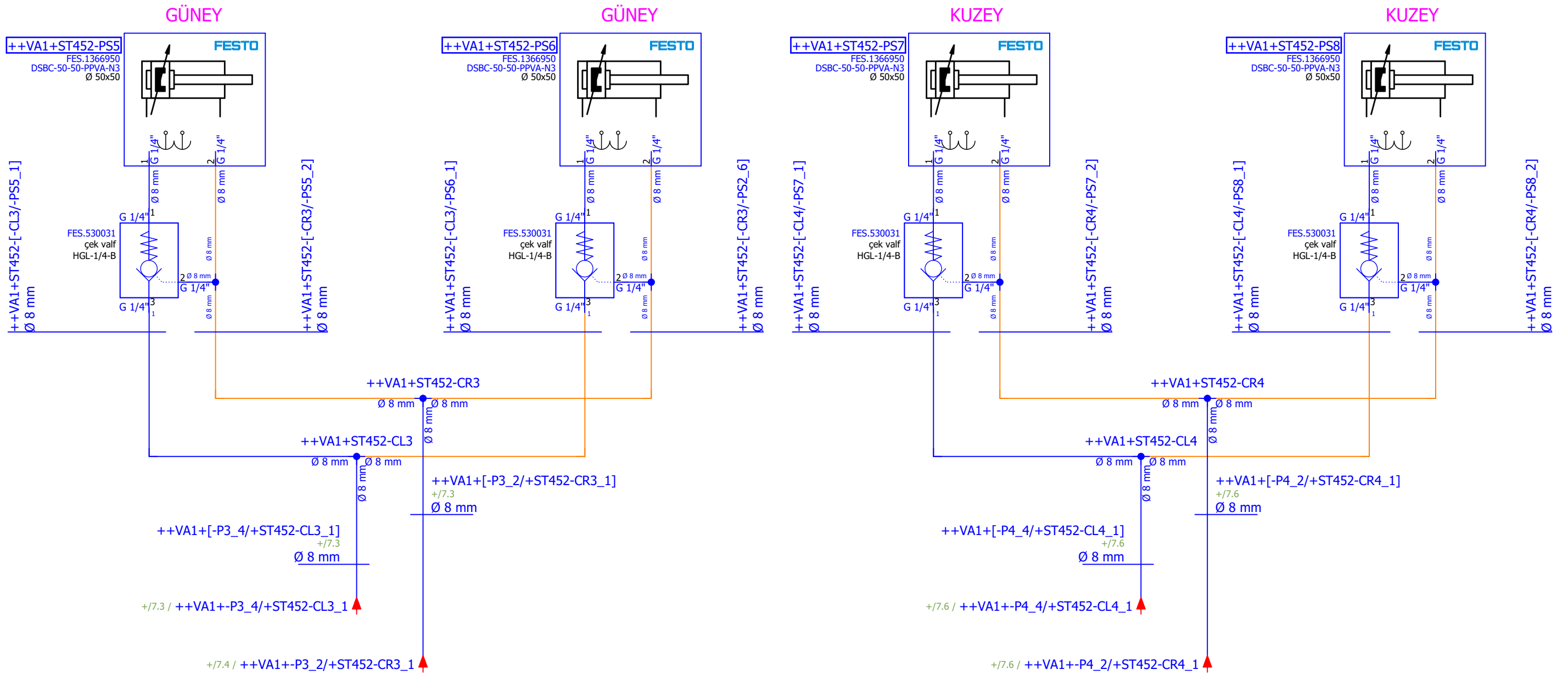

	Yeşilyurt, Muhtar Cafer Sk. No:8 41190 Başiskele/Kocaeli		<b>PROJE ADI</b>	<b>SAYFA AÇIKLAMASI</b>	Çizen: Hasancan Simen	Sayfa 1
	info@dssotomasyon.com.tr		PLC101 stoper	KAPAK	Kontrol Eden: Sabri Ebrem	++VA1
	+90 544 322 23 10					+ST452



 <p>Yeşilyurt, Muhtar Cafer Sk. No:8 41190 Başiskele/Kocaeli</p> <p>info@dssotomasyon.com.tr</p> <p>+90 544 322 23 10</p>		<p><b>PROJE ADI</b></p> <p>PLC101 stoper</p>	<p><b>SAYFA AÇIKLAMASI</b></p> <p>PİSTONLAR</p>	<p>Çizen: Hasancan Simen</p> <p>Kontrol Eden: Sabri Ebrem</p>	<p>Sayfa 2</p> <p>T. Sayfa 48 / 167</p>
		<p><b>++VA1</b></p> <p><b>+ST452</b></p>			

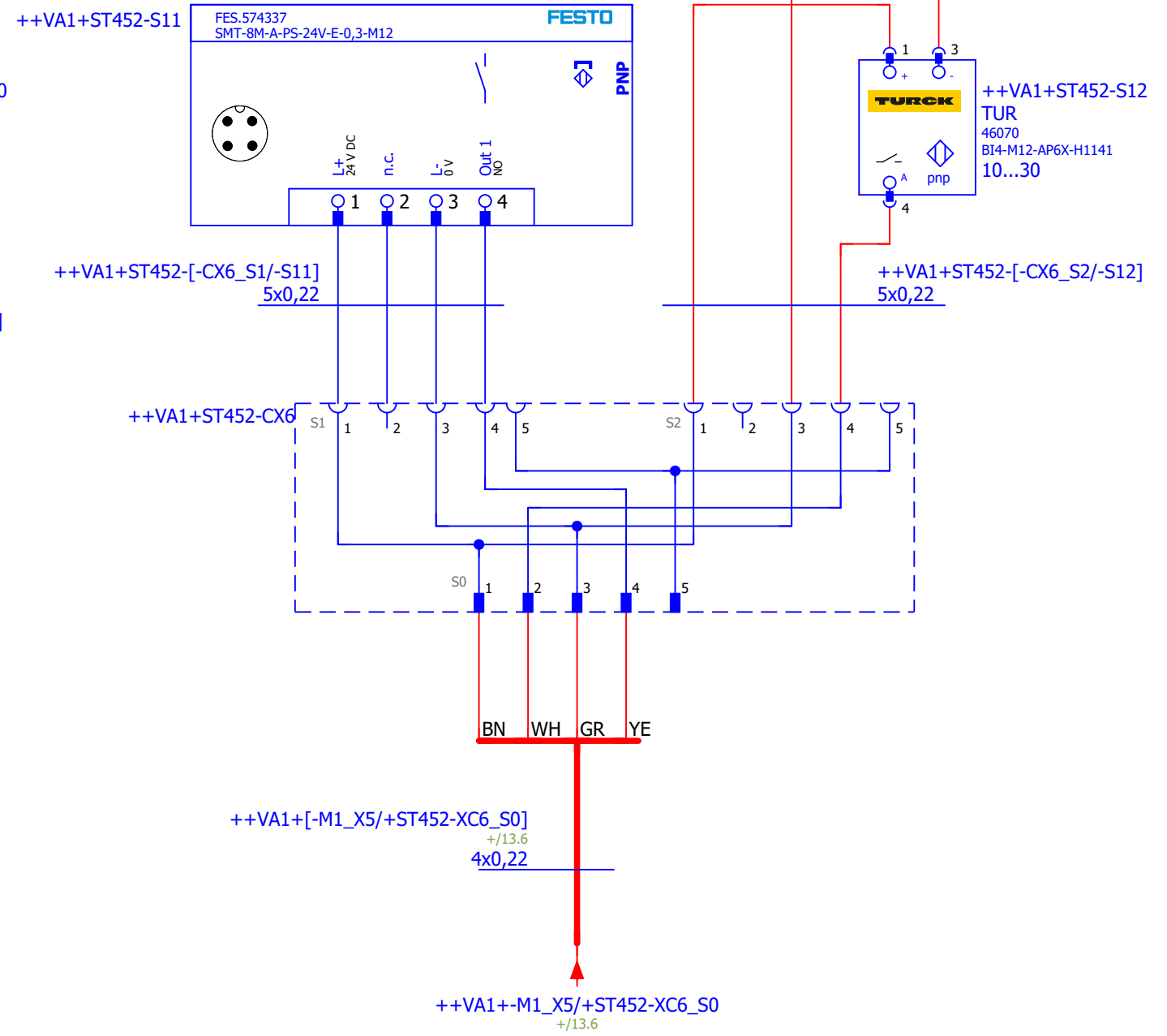
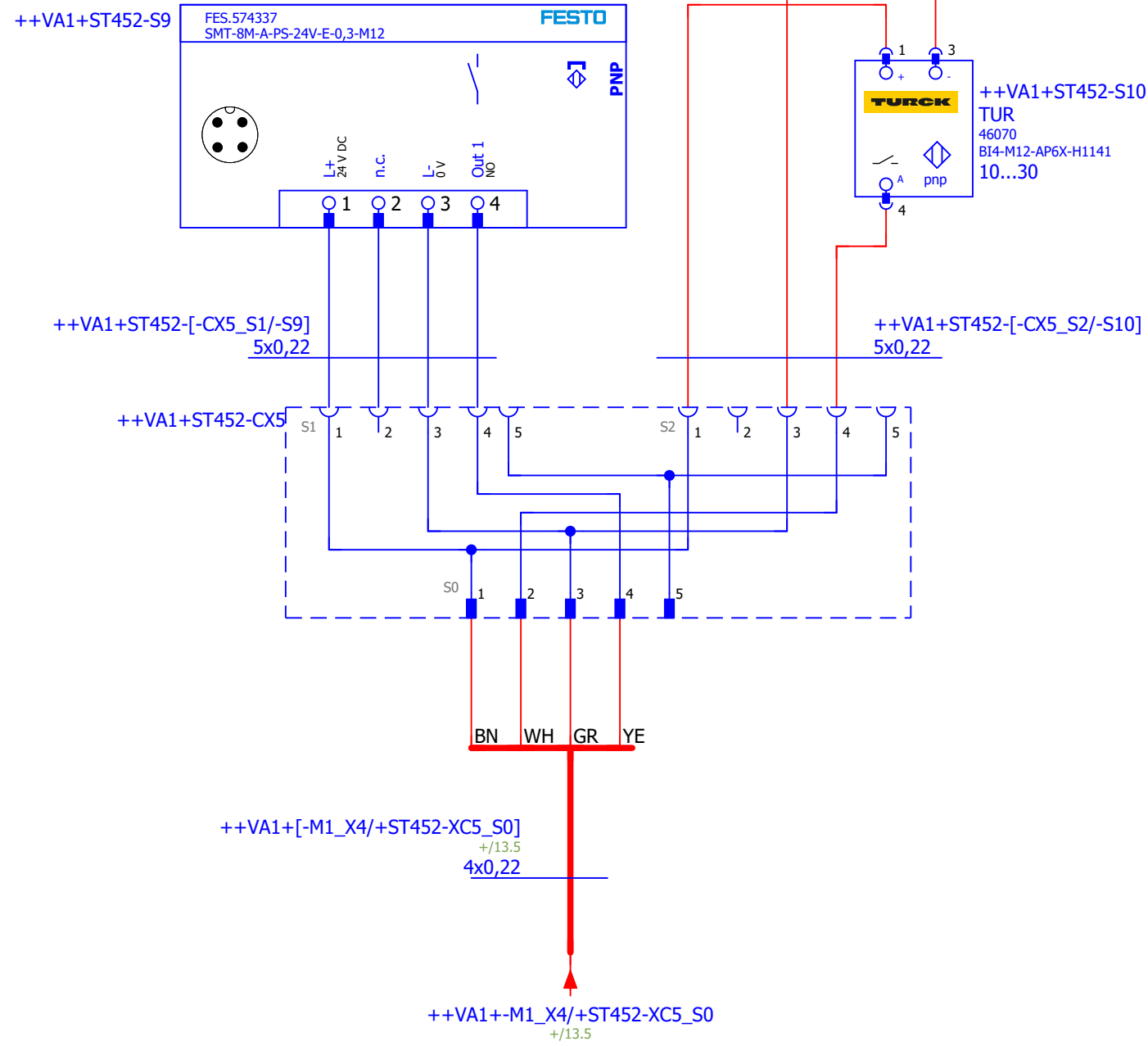

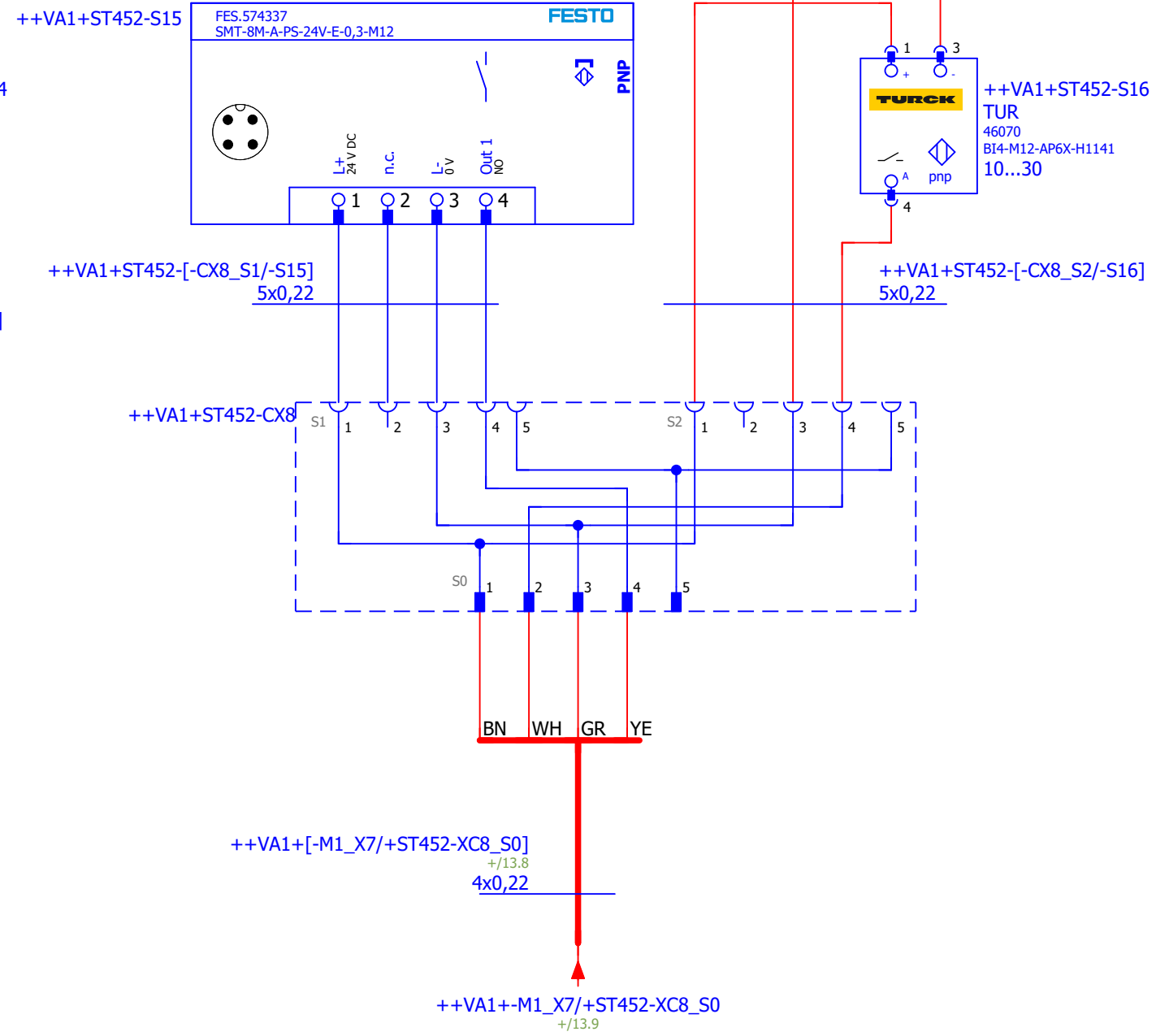
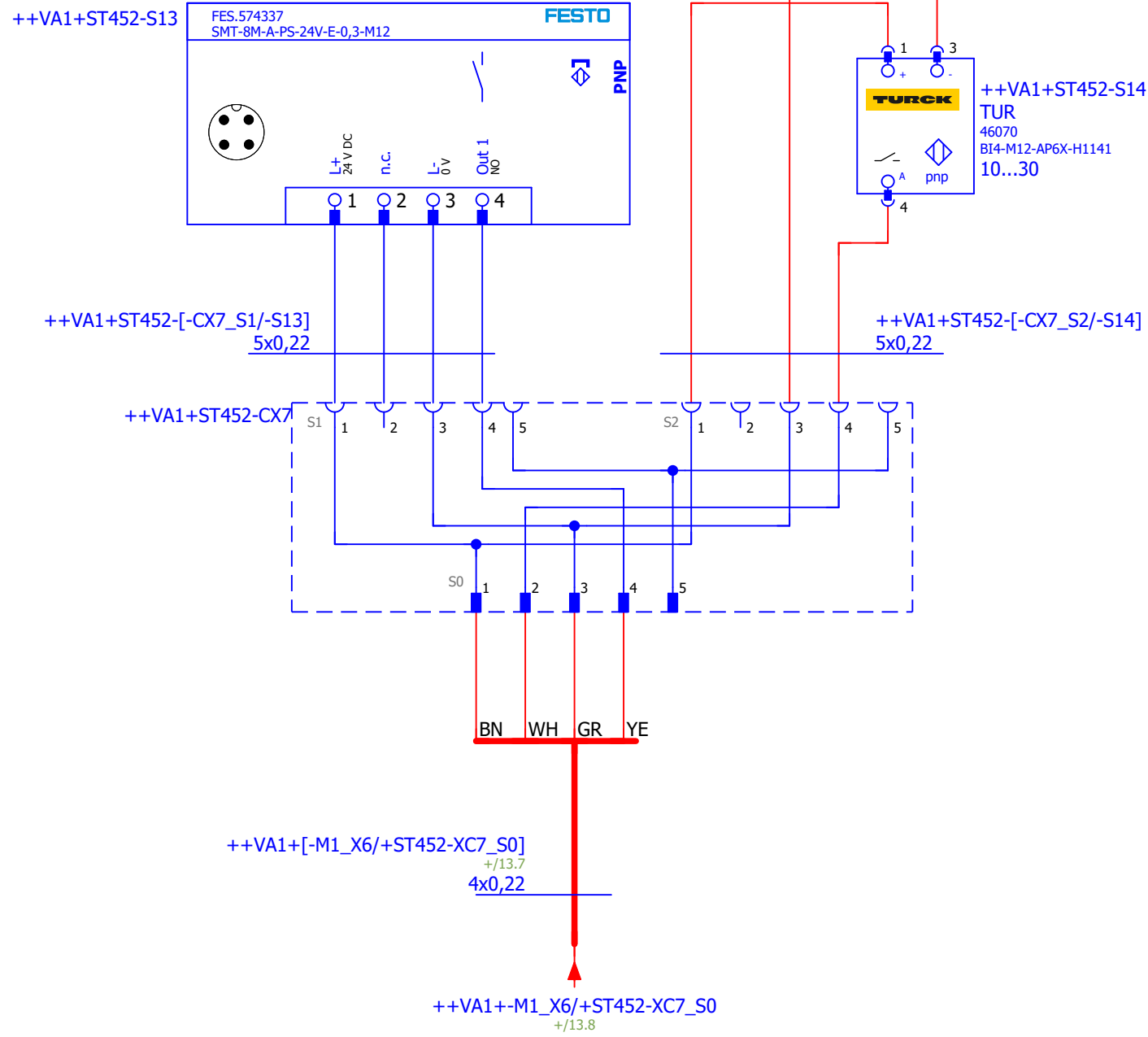

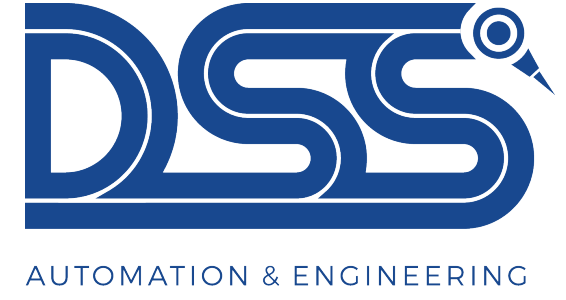



Müşteri : FORD OTOSAN

Üretici (şirket) : DSS OTOMASYON

+ST453

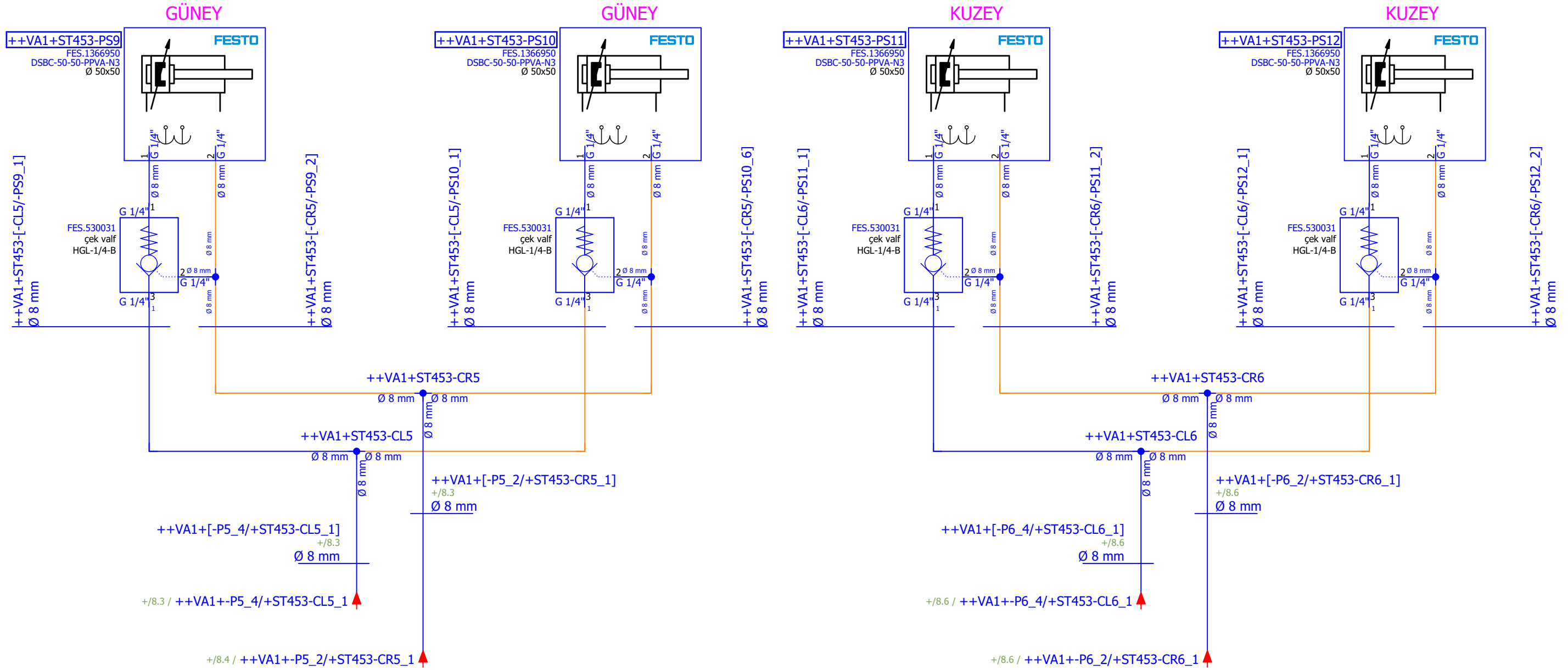



	Yeşilyurt, Muhtar Cafer Sk. No:8 41190 Başiskele/Kocaeli		<b>PROJE ADI</b>	<b>SAYFA AÇIKLAMASI</b>	Çizen: Hasancan Simen	Sayfa 3
	info@dssotomasyon.com.tr		PLC101 stoper	PİSTONLAR	Kontrol Eden: Sabri Ebrem	
	+90 544 322 23 10					





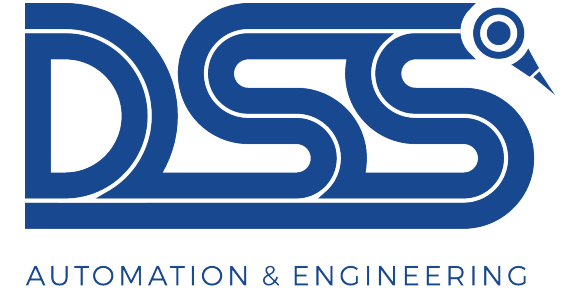

Müşteri : FORD OTOSAN

Üretici (şirket) : DSS OTOMASYON

+ST454



1

	Yeşilyurt, Muhtar Cafer Sk. No:8 41190 Başiskele/Kocaeli		<b>PROJE ADI</b>	<b>SAYFA AÇIKLAMASI</b>	Çizen: Hasancan Simen	Sayfa 1
	info@dssotomasyon.com.tr		PLC101 stoper	KAPAK	Kontrol Eden: Sabri Ebrem	++VA1
	+90 544 322 23 10					+ST454

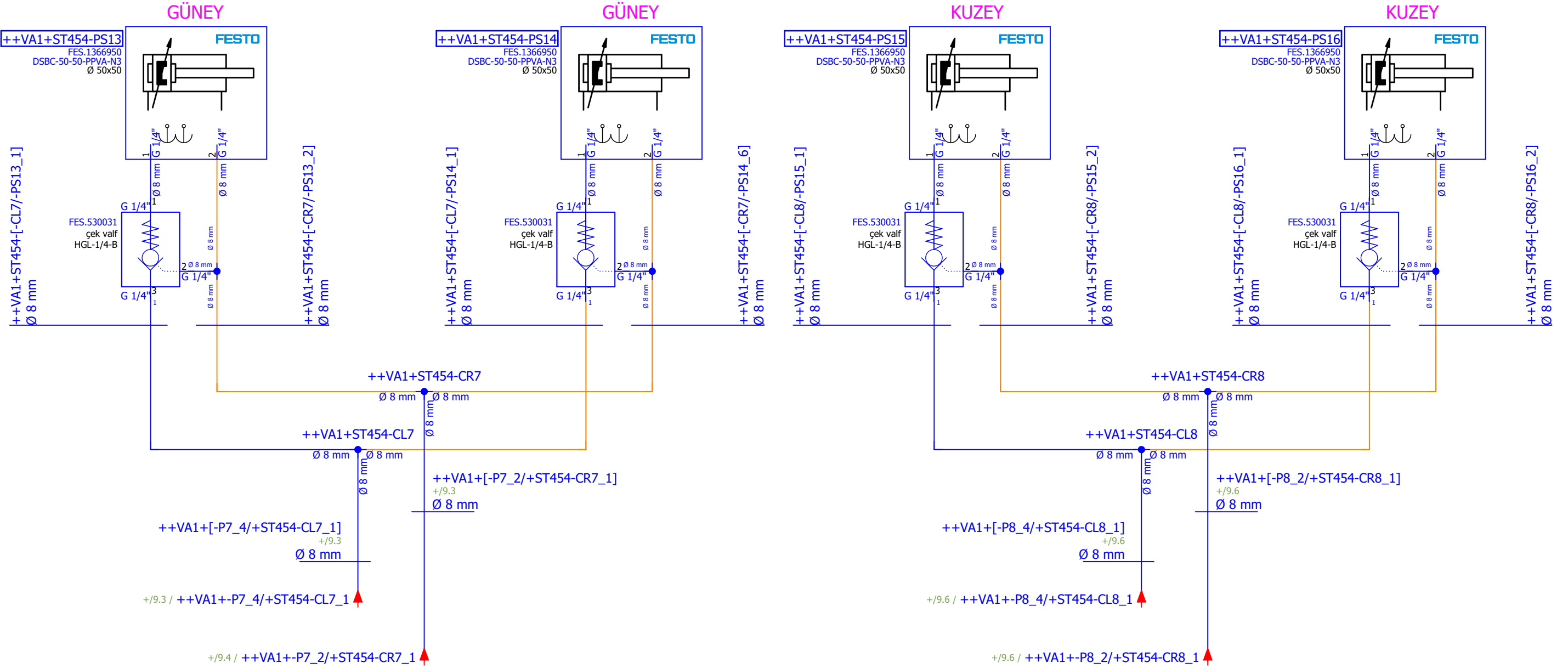

<p>Yeşilyurt, Muhtar Cafer Sk. No:8 41190 Başiskele/Kocaeli</p> <p>info@dssotomasyon.com.tr</p> <p>+90 544 322 23 10</p>		<p><b>PROJE ADI</b></p> <p>PLC101 stoper</p>	<p><b>SAYFA AÇIKLAMASI</b></p> <p>PİSTONLAR</p>	<p>Çizen: Hasancan Simen</p> <p>Kontrol Eden: Sabri Ebrem</p>	<p>Sayfa 4</p> <p>T. Sayfa 56 / 167</p>
		<p><b>++VA1</b></p> <p><b>+ST454</b></p>			

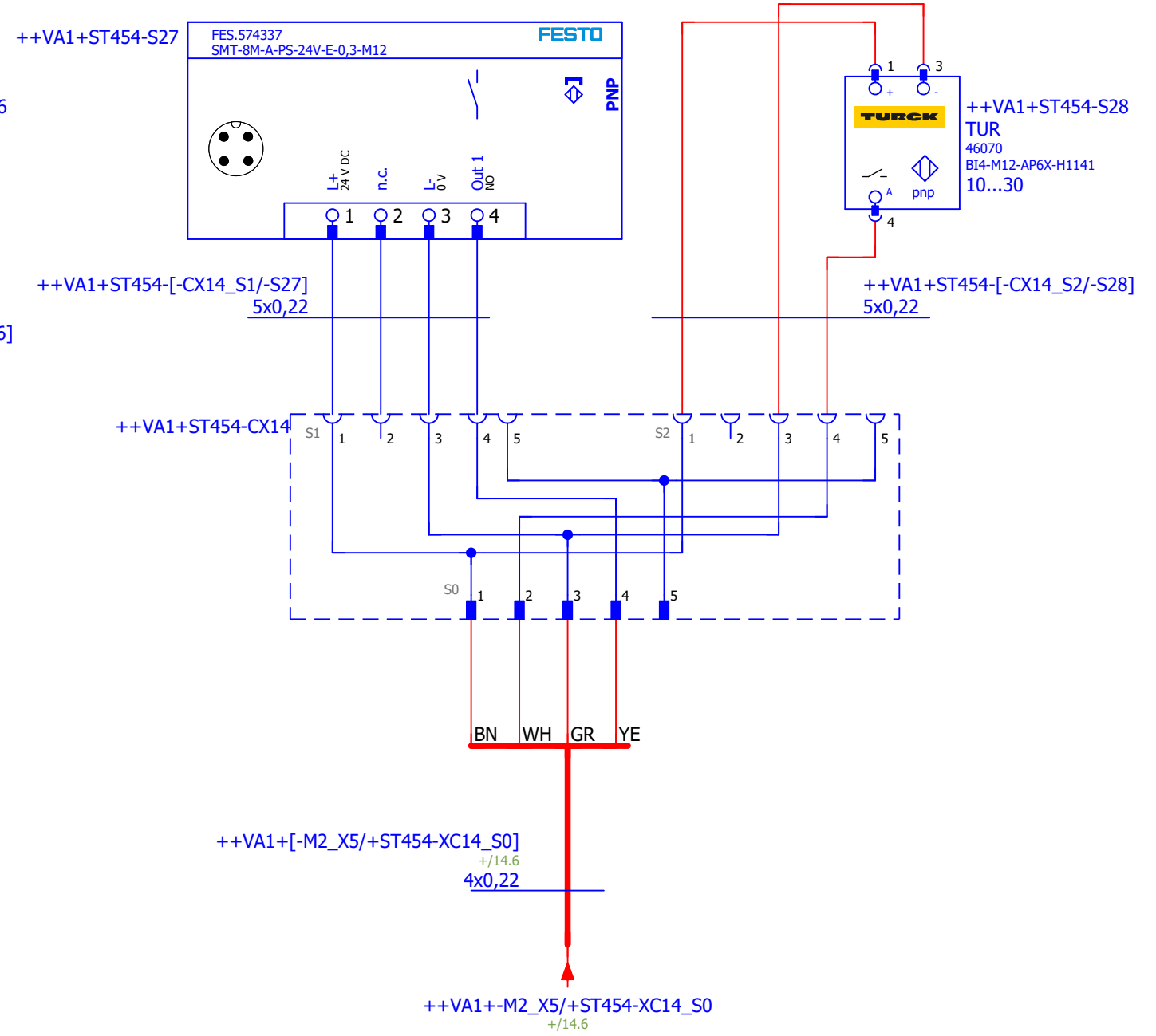
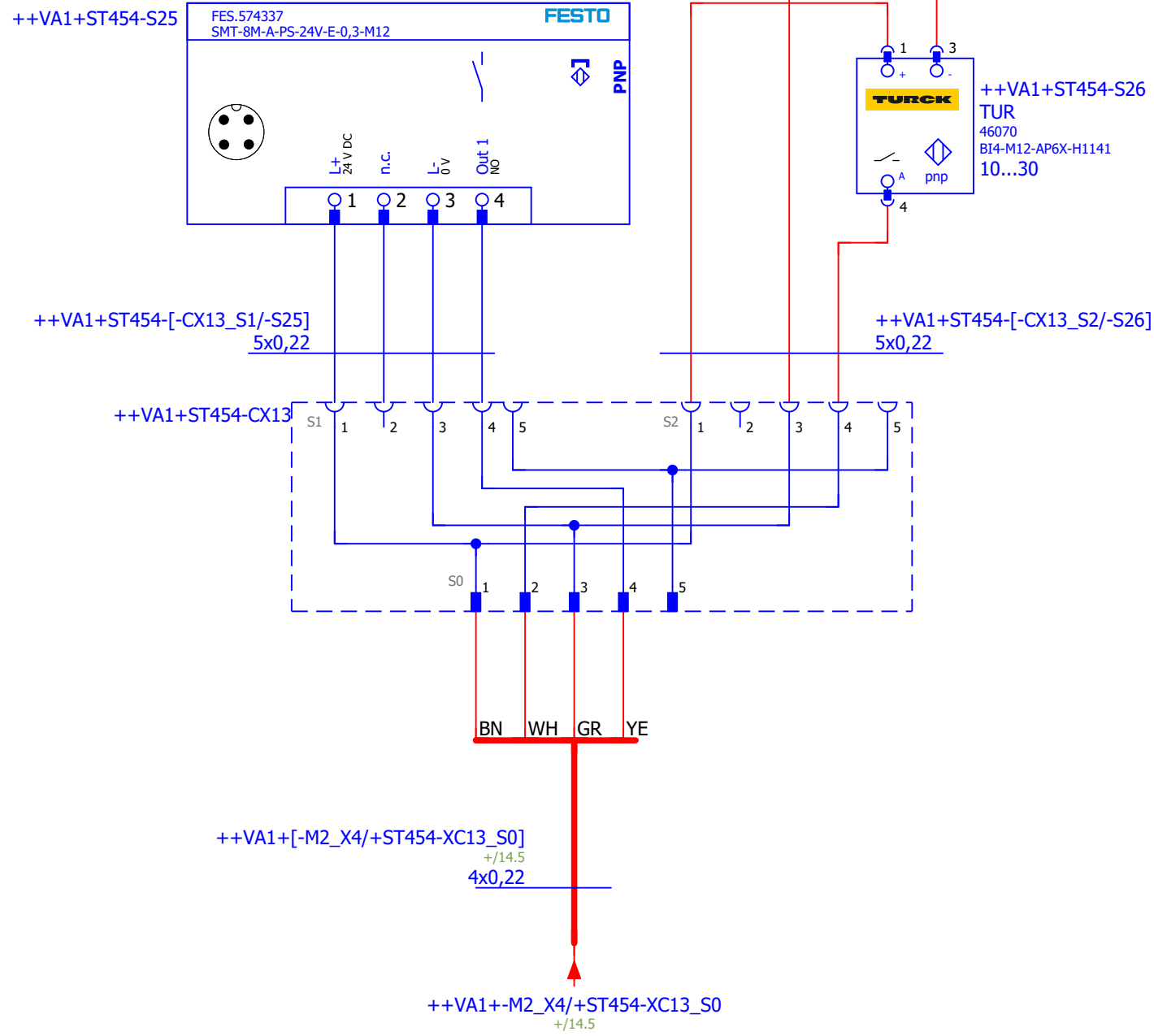

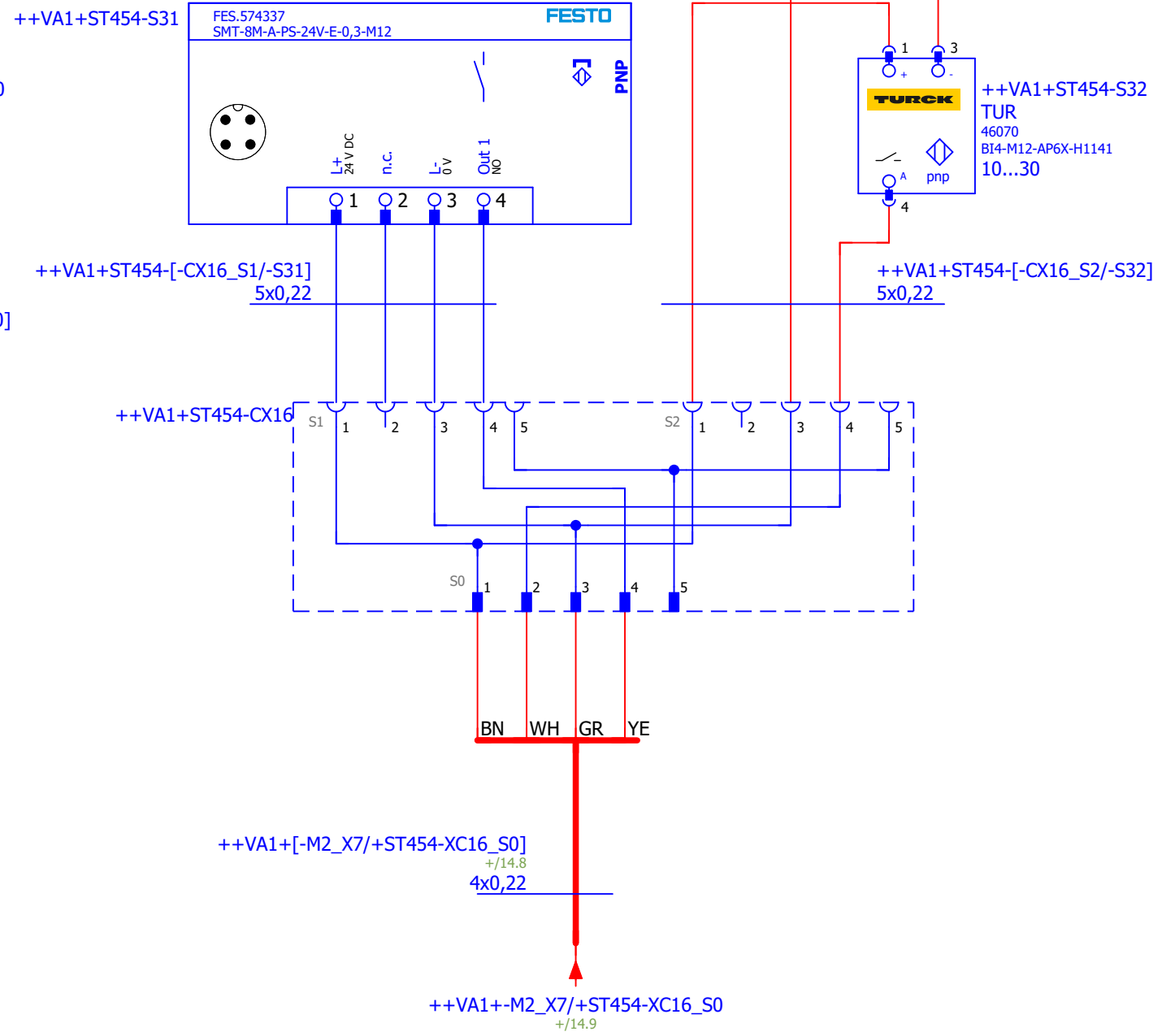
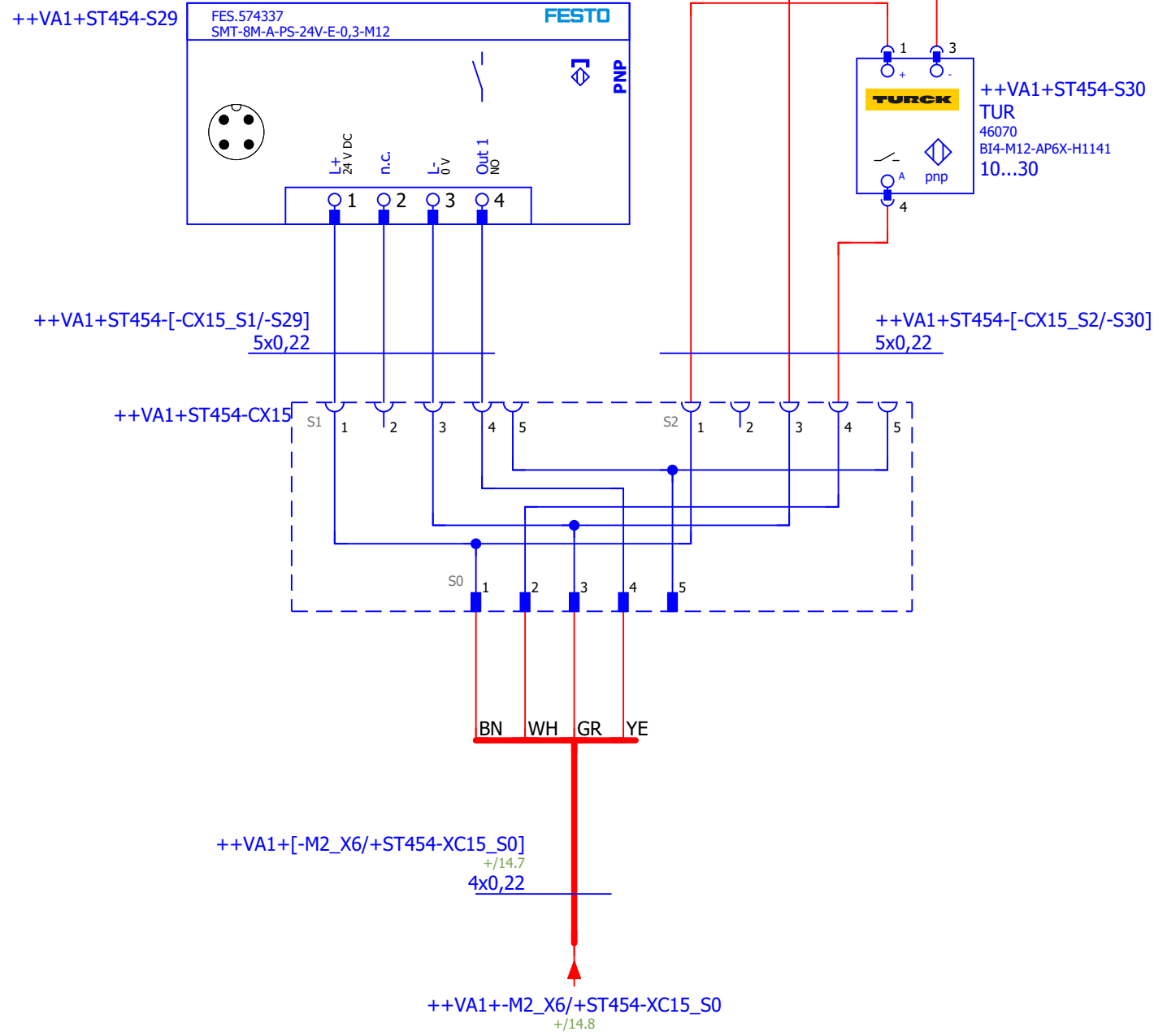

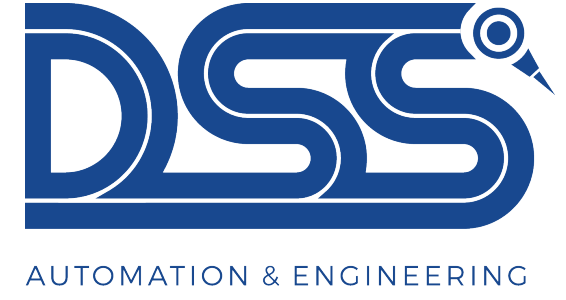

Müşteri : FORD OTOSAN

Üretici (şirket) : DSS OTOMASYON

+ST455



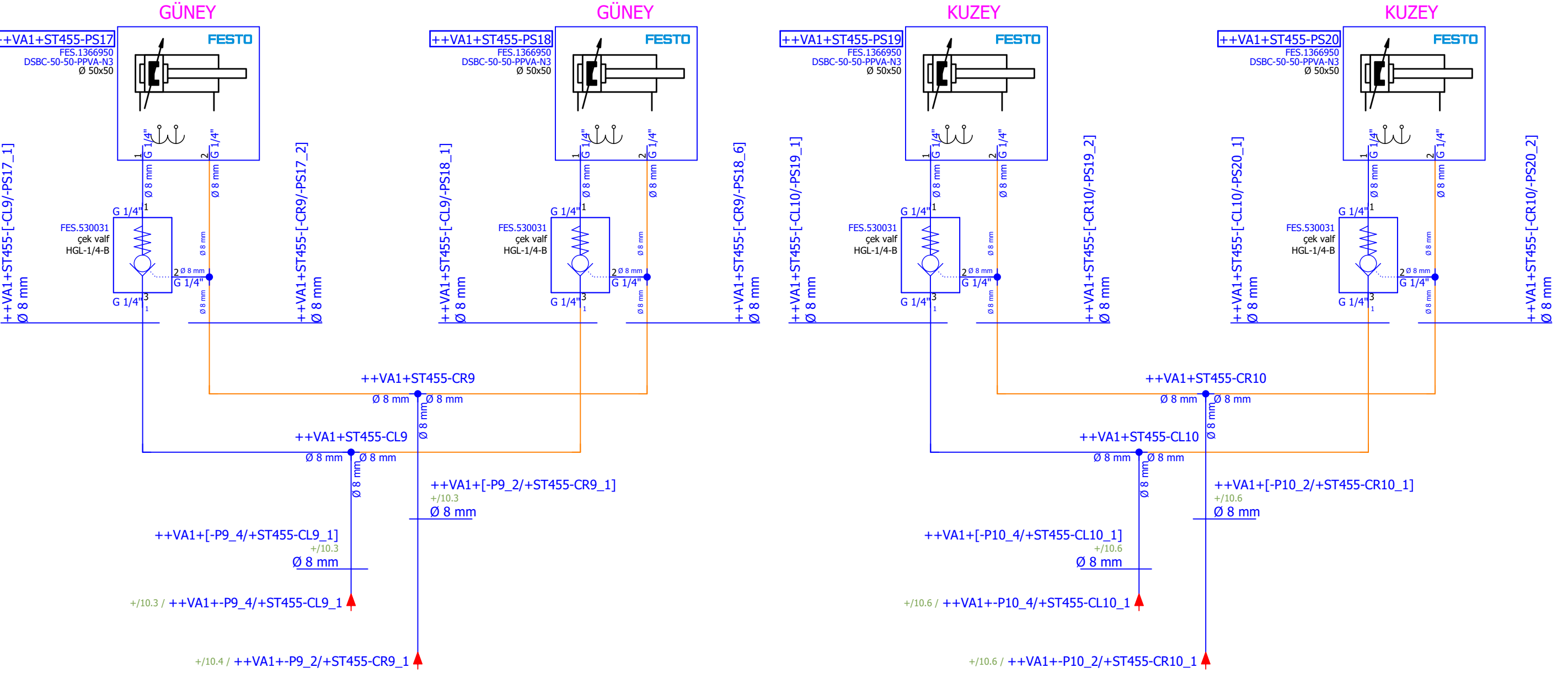

	Yeşilyurt, Muhtar Cafer Sk. No:8 41190 Başiskele/Kocaeli		<b>PROJE ADI</b>	<b>SAYFA AÇIKLAMASI</b>	Çizen: Hasancan Simen	Sayfa 5
	info@dssotomasyon.com.tr		PLC101 stoper	PİSTONLAR	Kontrol Eden: Sabri Ebrem	
	+90 544 322 23 10					++VA1 +ST455

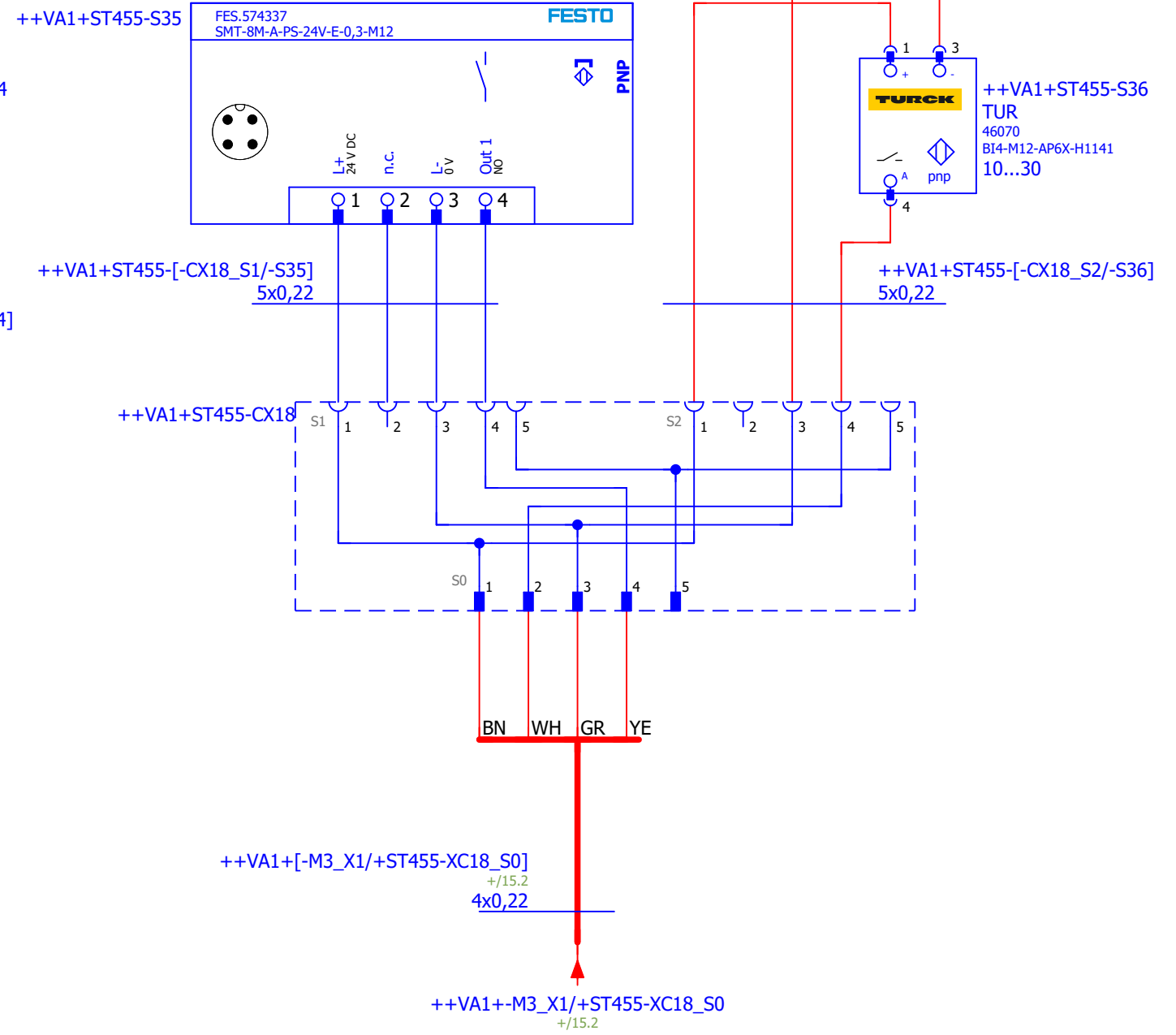
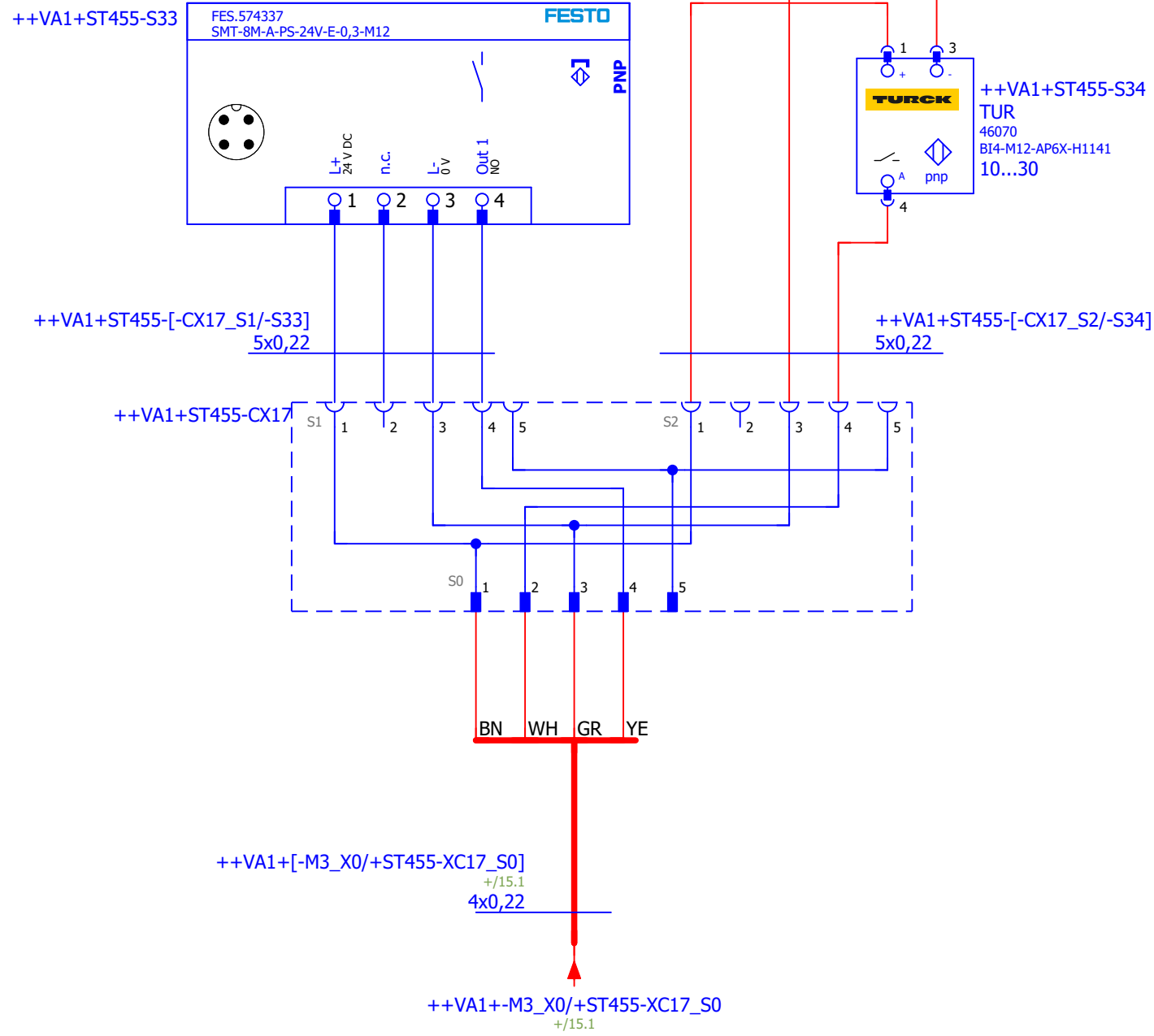

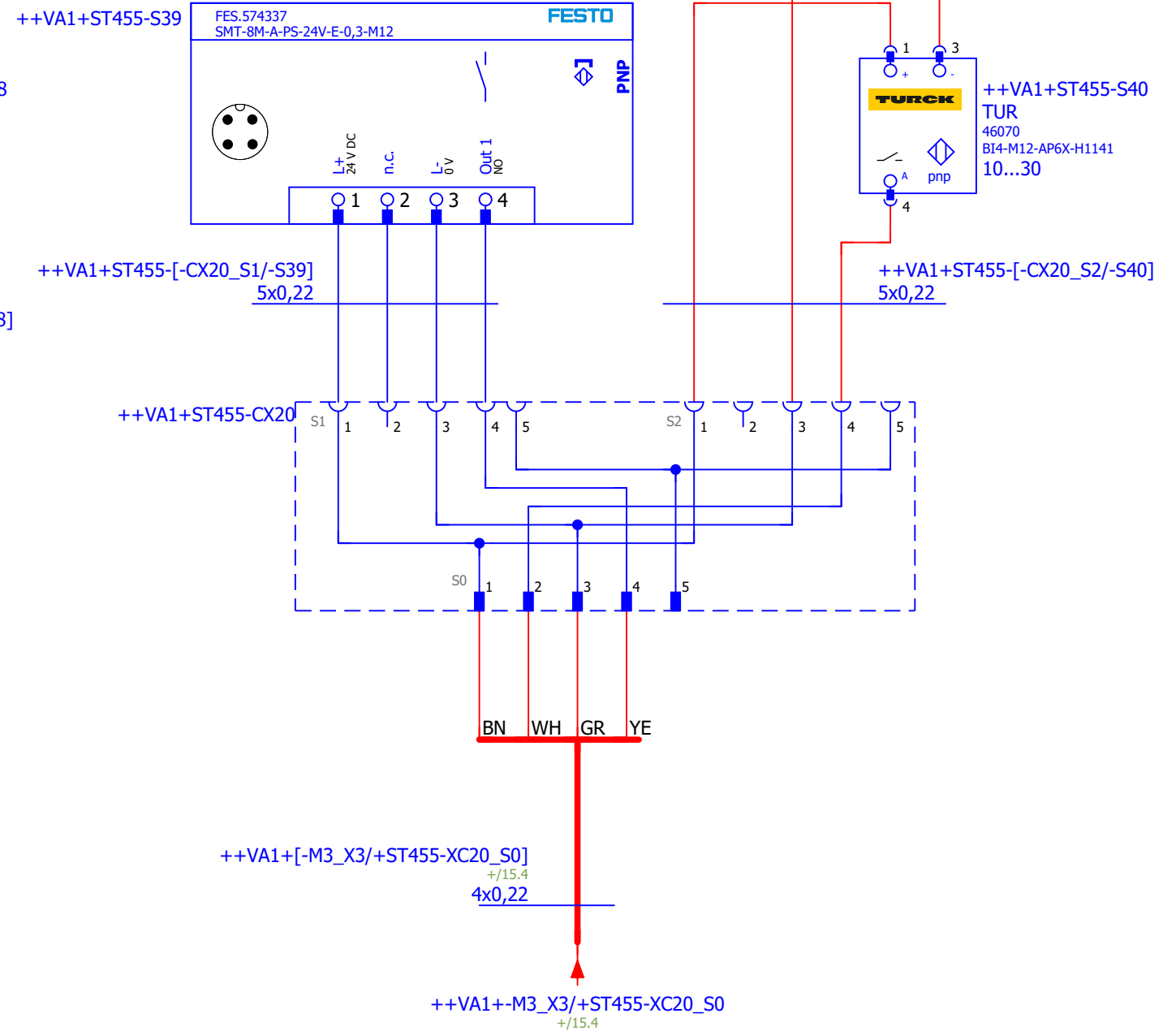
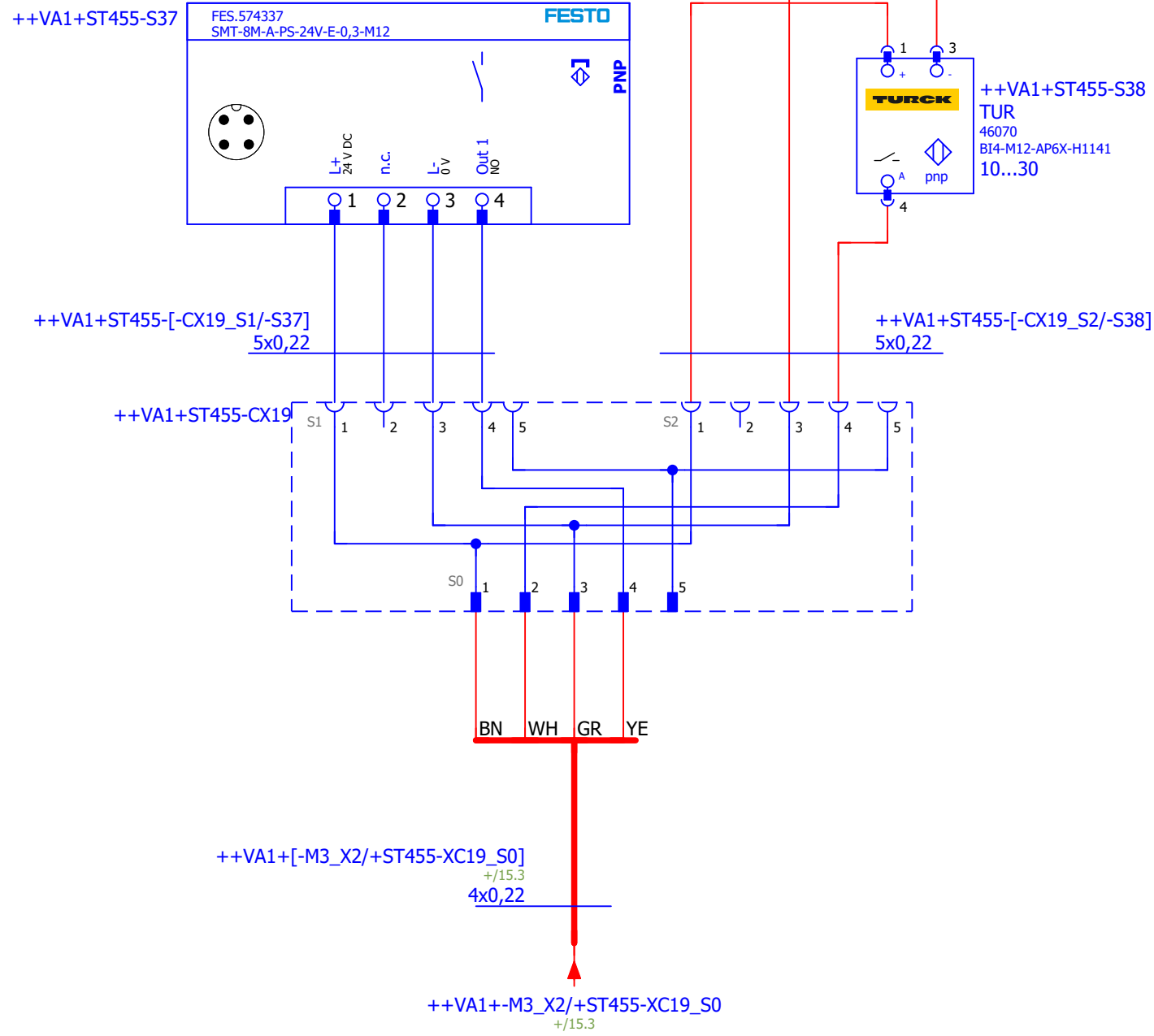

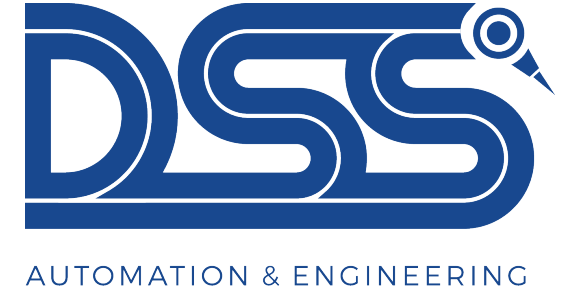

Müşteri : FORD OTOSAN

Üretici (şirket) : DSS OTOMASYON

+ST456



1

	Yeşilyurt, Muhtar Cafer Sk. No:8 41190 Başiskele/Kocaeli		<b>PROJE ADI</b>	<b>SAYFA AÇIKLAMASI</b>	Çizen: Hasancan Simen	Sayfa 1
	info@dssotomasyon.com.tr		PLC101 stoper	KAPAK	Kontrol Eden: Sabri Ebrem	++VA1
	+90 544 322 23 10					+ST456

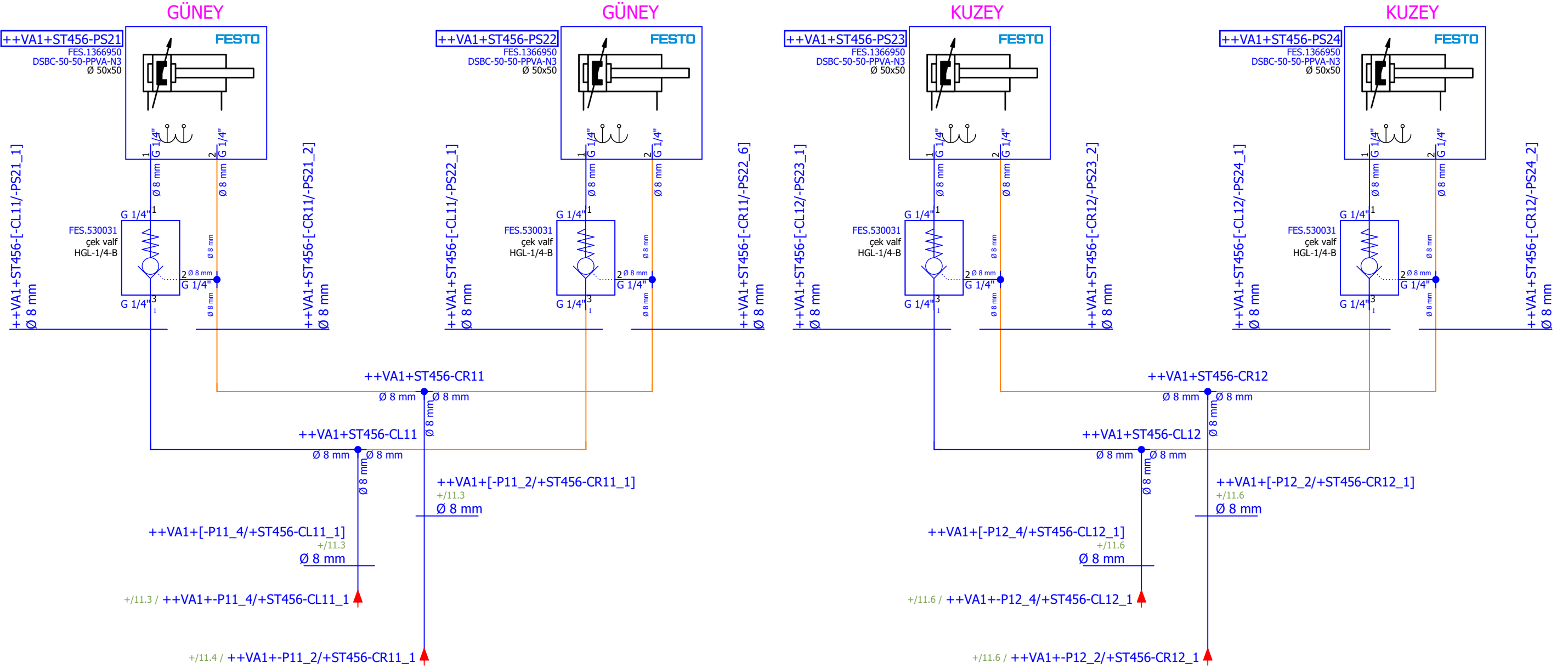

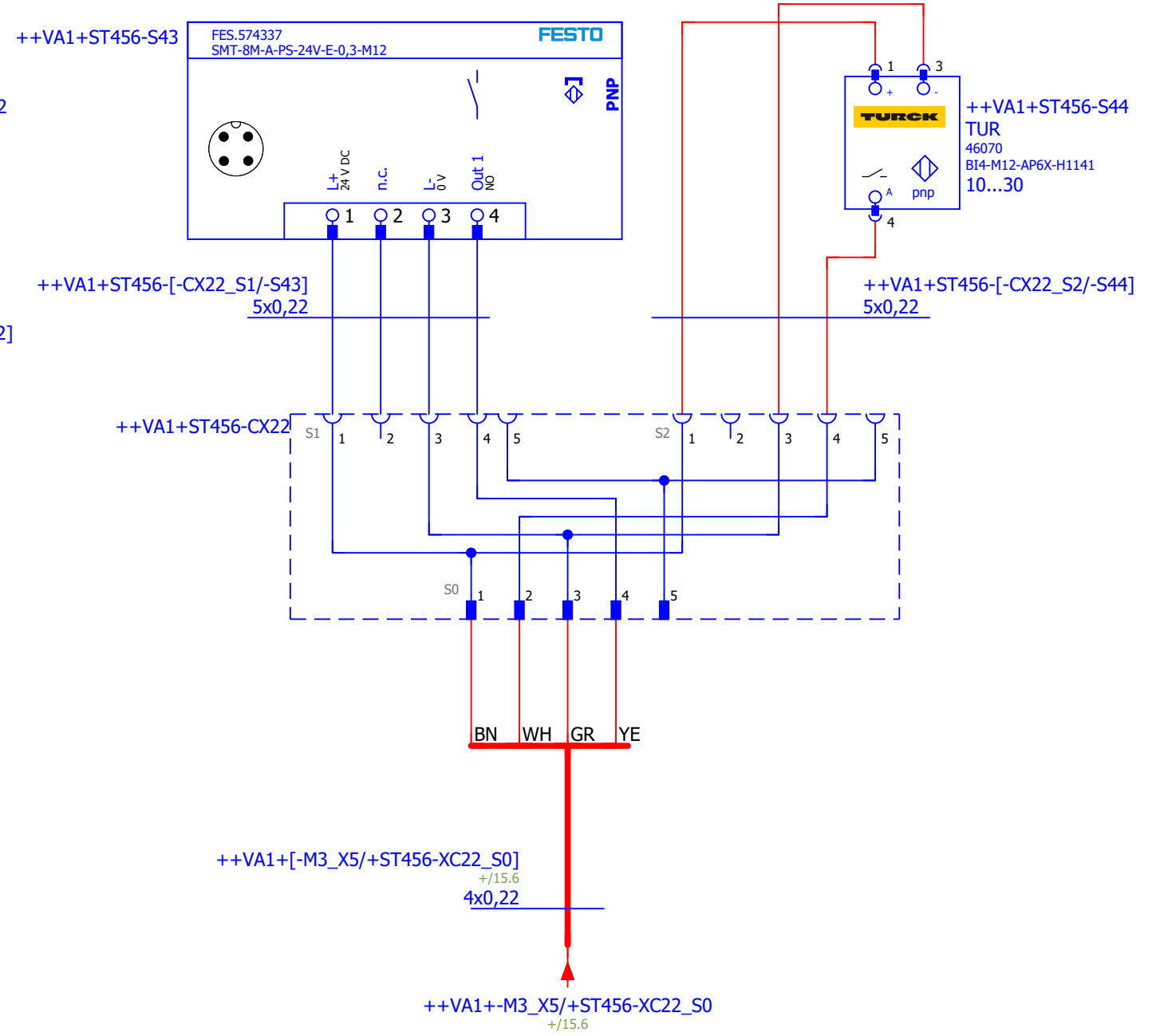
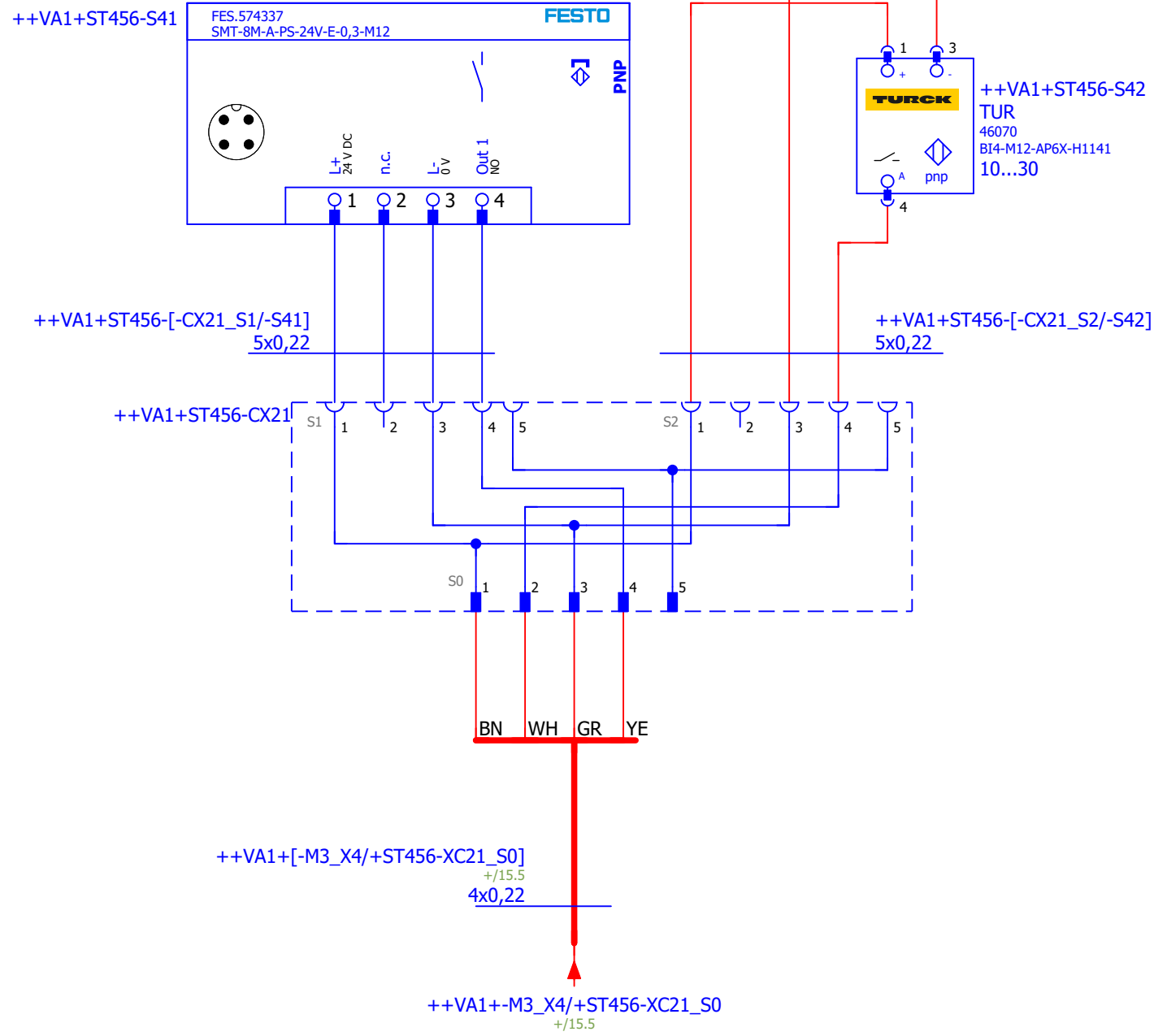

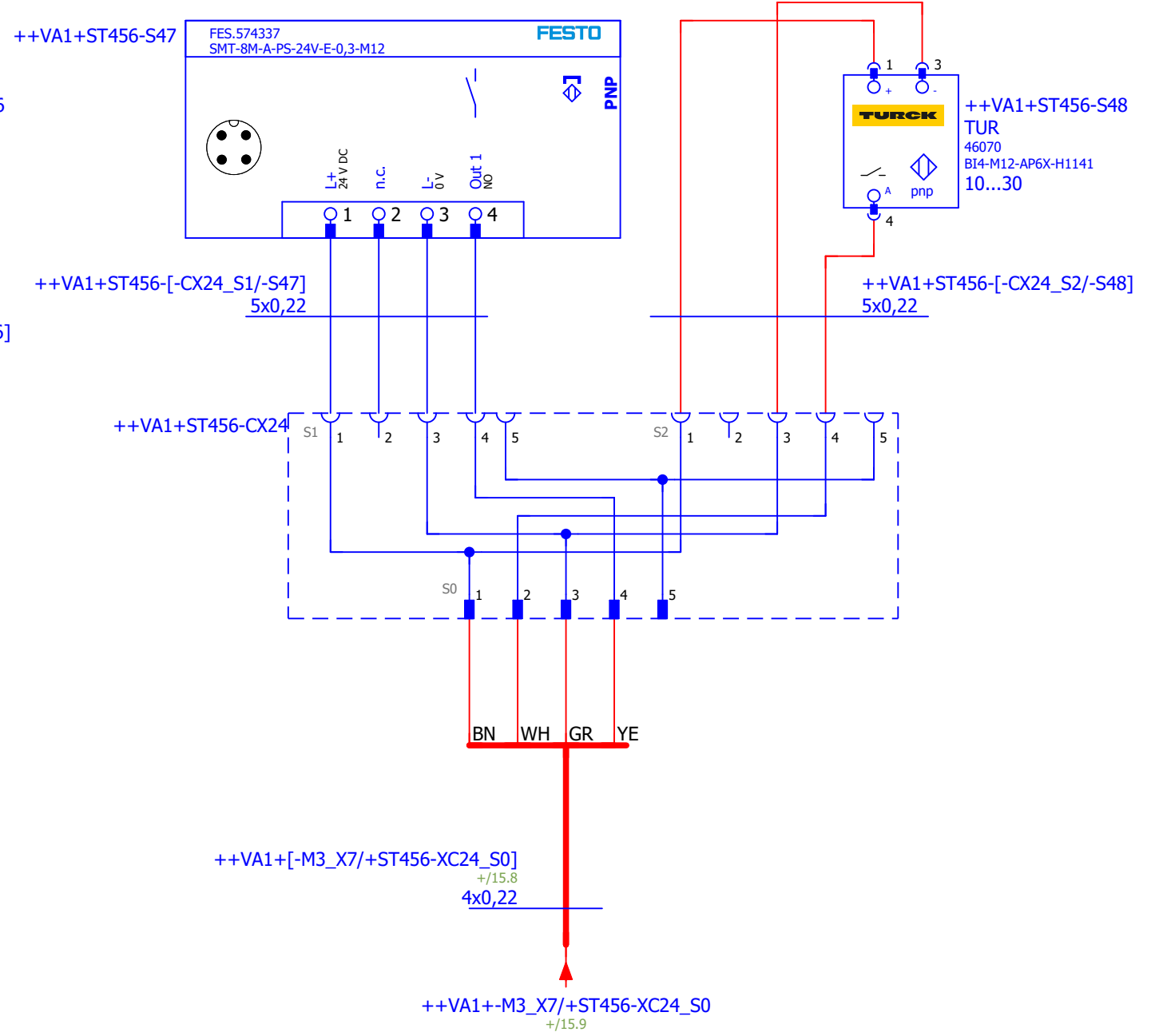
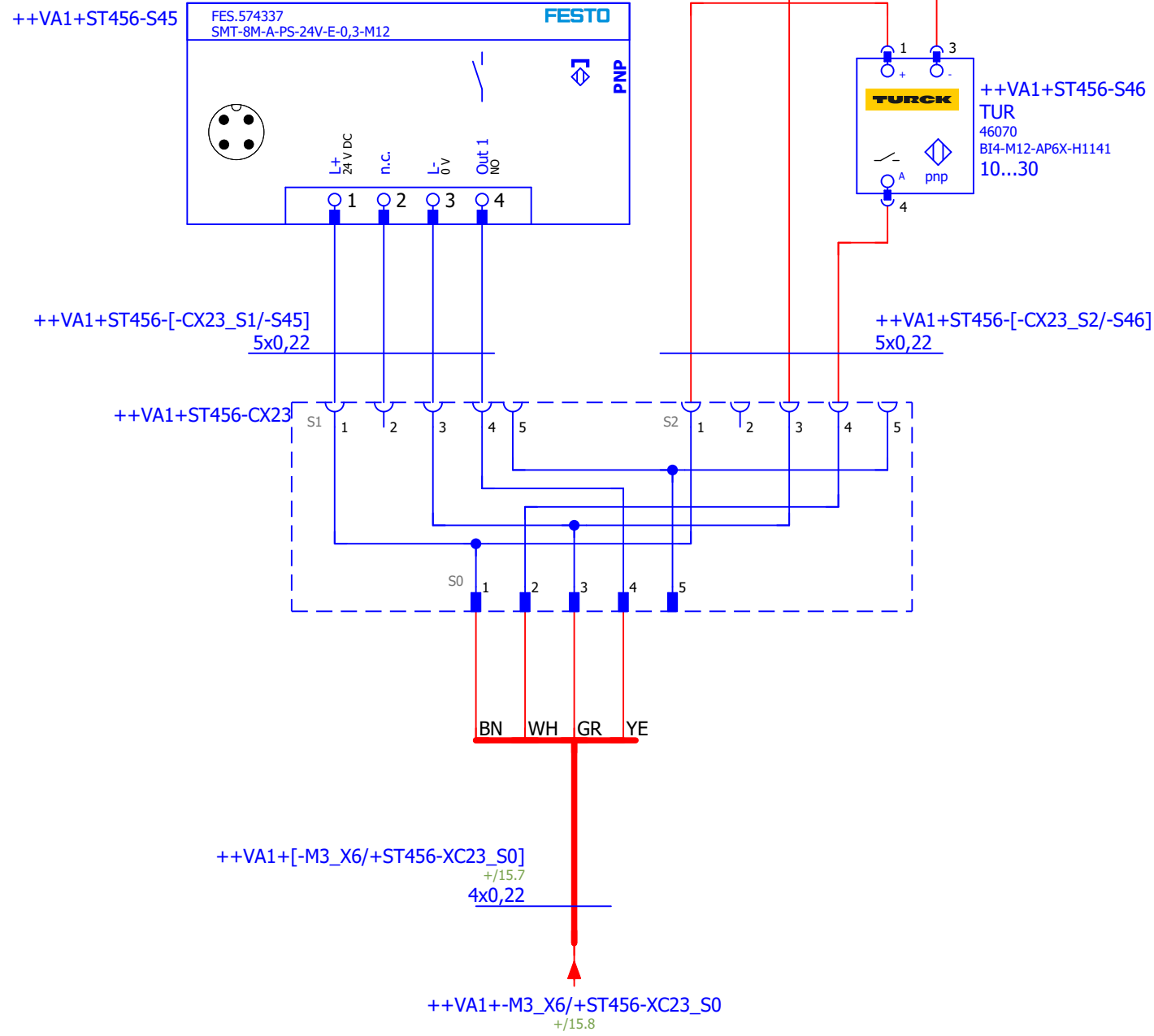

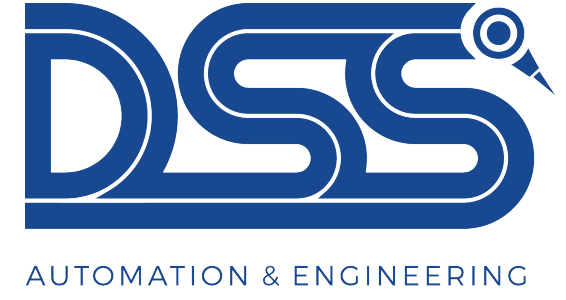

Müşteri : FORD OTOSAN

Üretici (şirket) : DSS OTOMASYON

++VA2



	Yeşilyurt, Muhtar Cafer Sk. No:8 41190 Başiskele/Kocaeli		<b>PROJE ADI</b>	<b>SAYFA AÇIKLAMASI</b>	Çizen: Hasancan Simen	Sayfa 1
	info@dssotomasyon.com.tr		PLC101 stoper	KAPAK	Kontrol Eden: Sabri Ebrem	++VA2
	+90 544 322 23 10					+

KUZHEY

GÜNEY

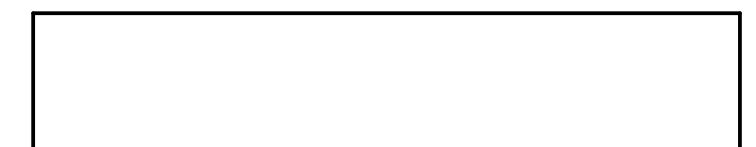
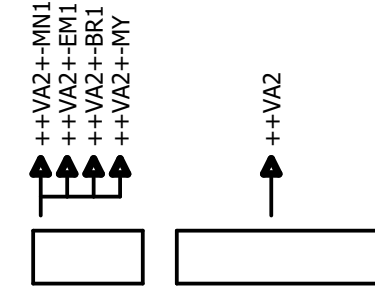
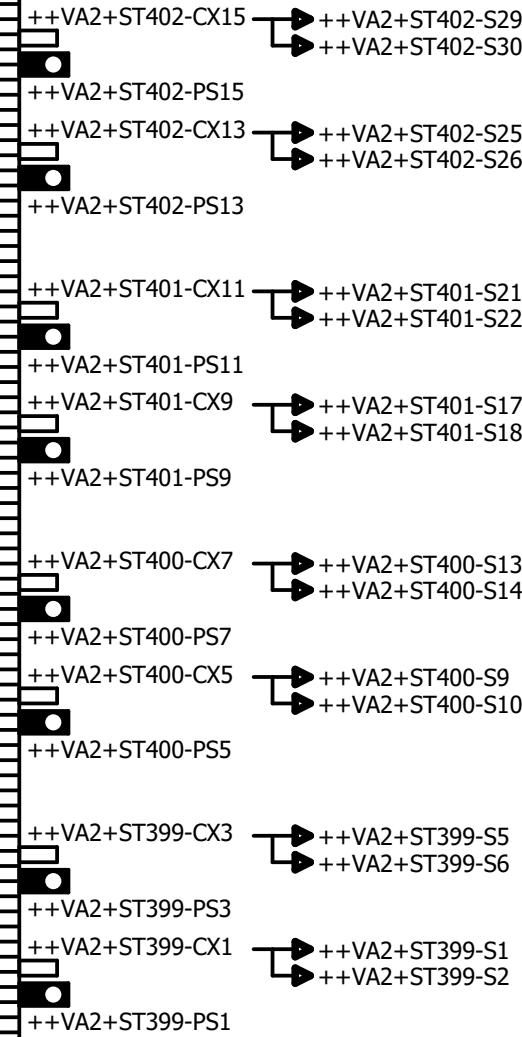
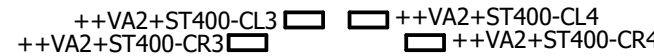
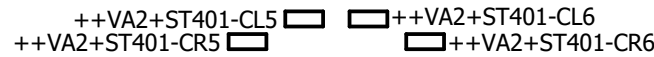
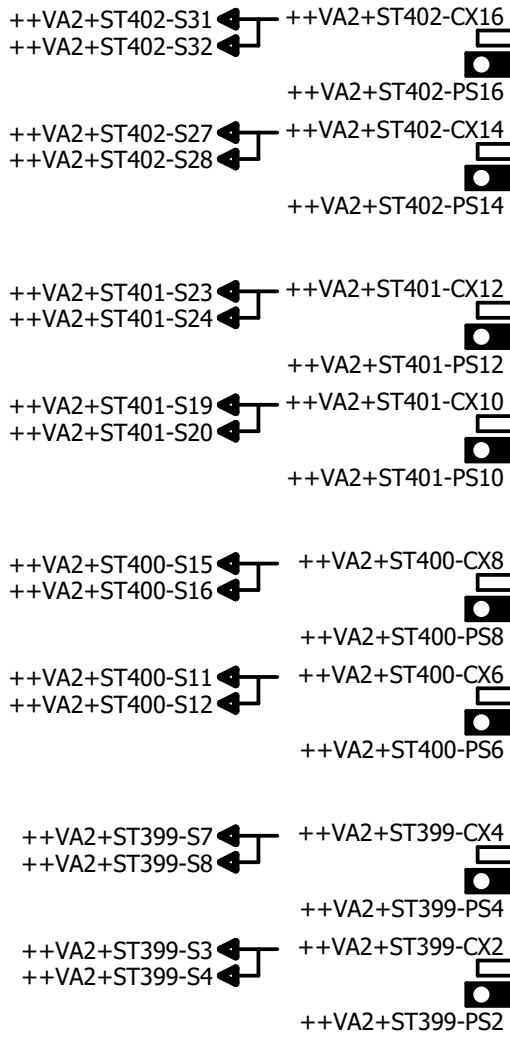
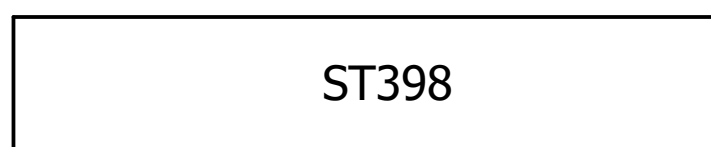
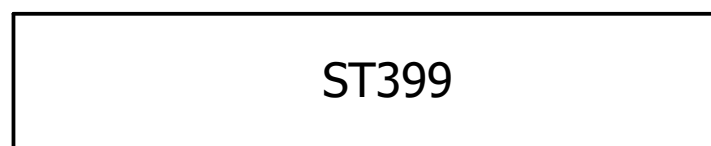
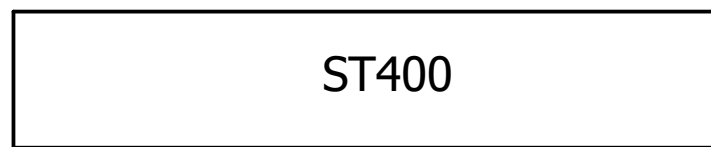
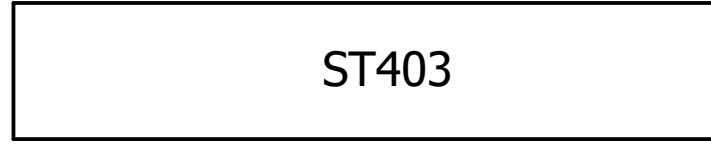

1.a



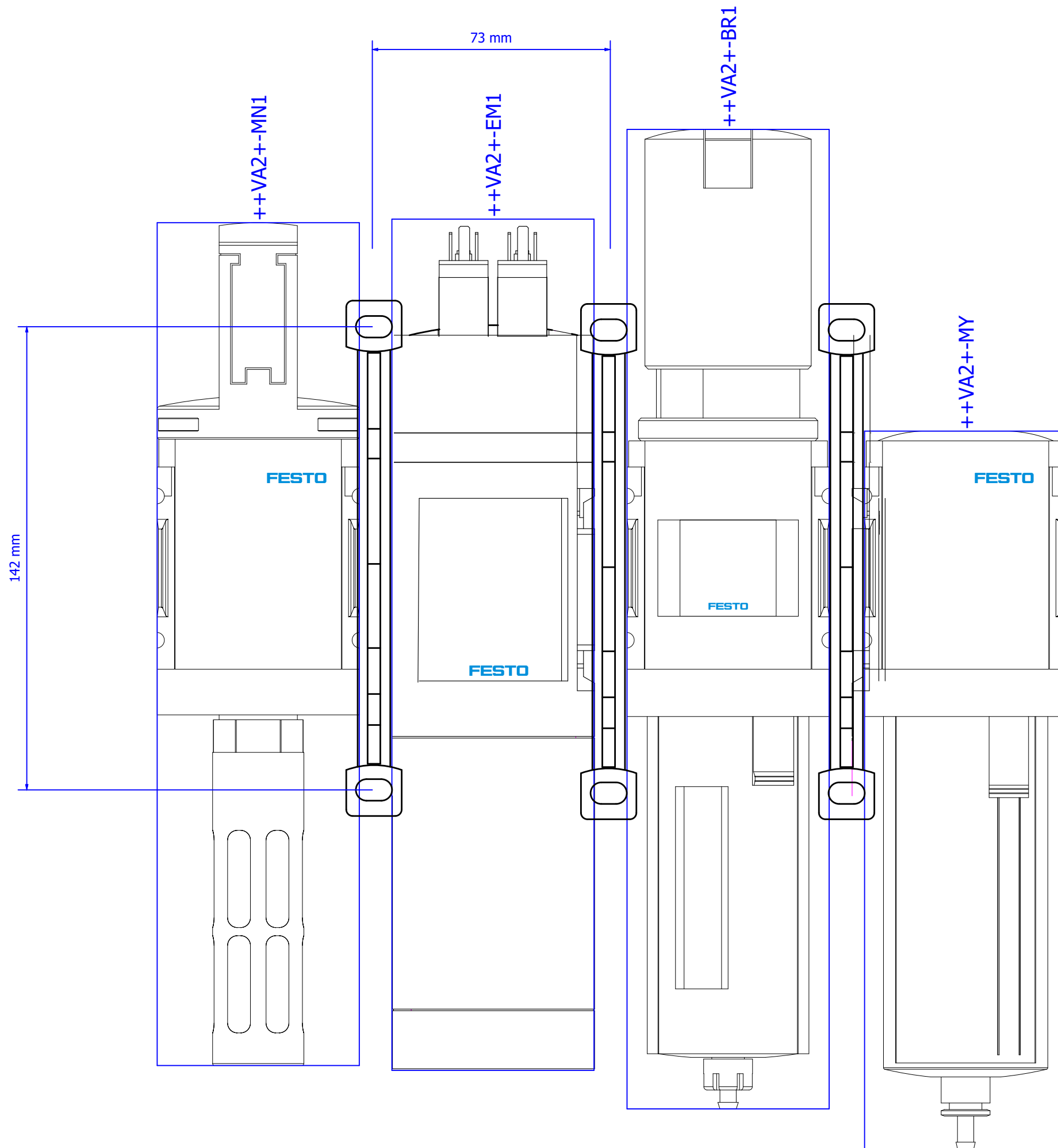

2



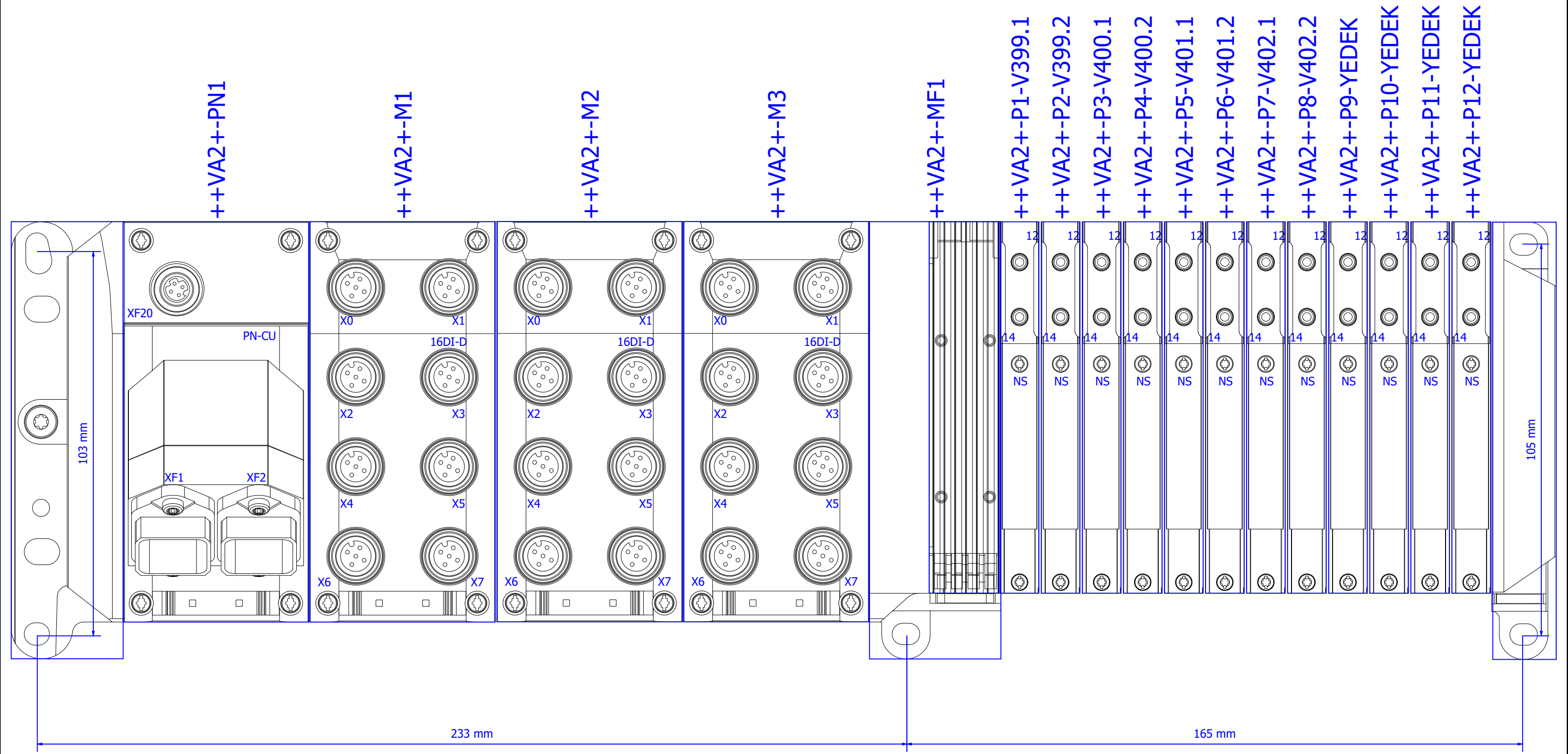

	Yeşilyurt, Muhtar Cafer Sk. No:8 41190 Başiskele/Kocaeli		<b>PROJE ADI</b>	<b>SAYFA AÇIKLAMASI</b>	Çizen: Hasancan Simen	Sayfa 3
	info@dssotomasyon.com.tr		PLC101 stoper	MOTAJ PLAKASI	Kontrol Eden: Sabri Ebrem	++VA2 +
+90 544 322 23 10						

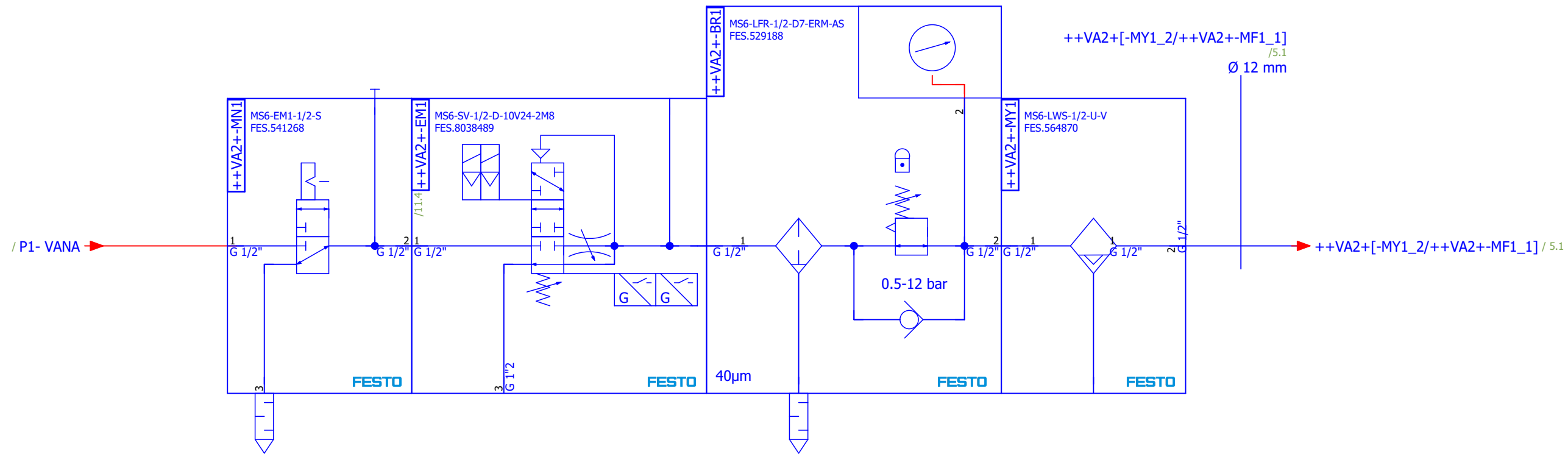

<b>PROJE ADI</b>	PLC101 stoper
------------------	---------------

<b>SAYFA AÇIKLAMASI</b>	ŞARTLANDIRICI
-------------------------	---------------

Çizen:	Hasancan Simen
Kontrol Eden:	Sabri Ebrem

++VA2	
+	

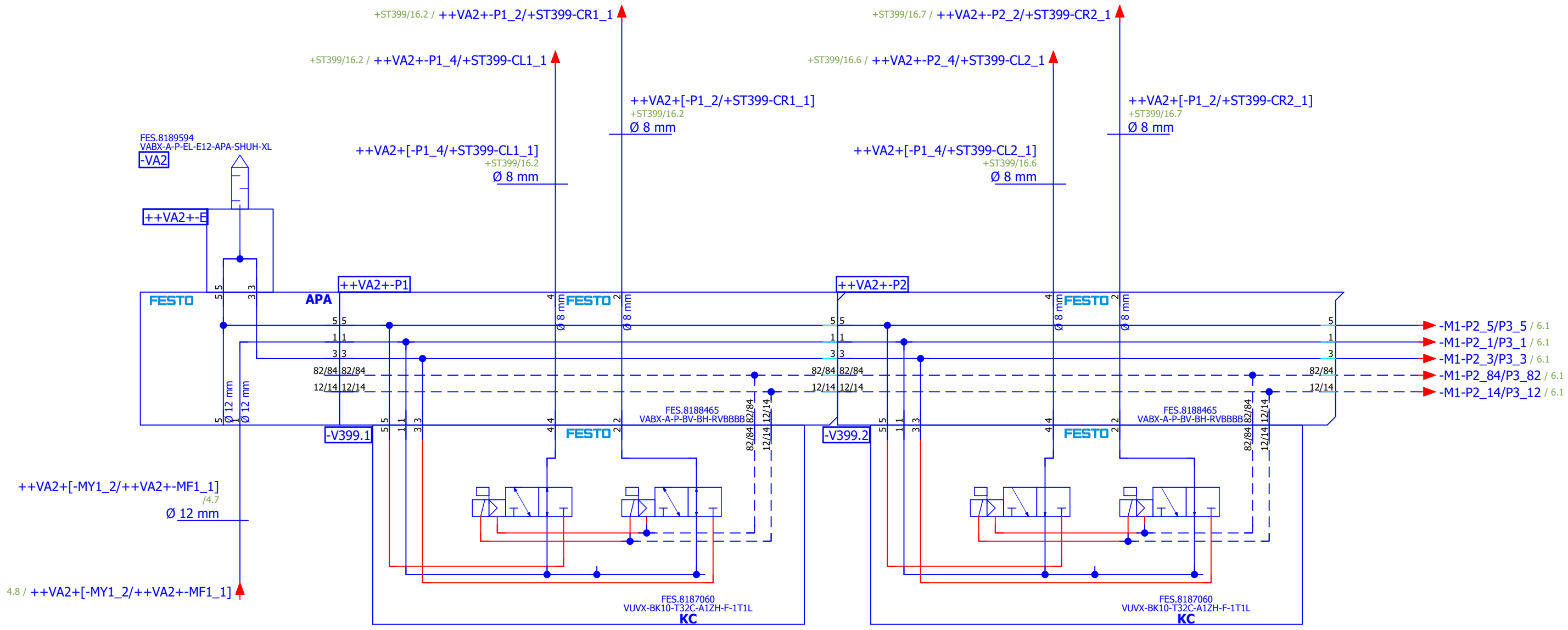

++VA2+[-MY1\_2/++VA2+-MF1\_1]  
/4.7  
Ø 12 mm

4.8 / ++VA2+[-MY1\_2/++VA2+-MF1\_1]

- -M1-P2\_5/P3\_5 / 6.1
- -M1-P2\_1/P3\_1 / 6.1
- -M1-P2\_3/P3\_3 / 6.1
- -M1-P2\_84/P3\_82 / 6.1
- -M1-P2\_14/P3\_12 / 6.1

<p>Yeşilyurt, Muhtar Cafer Sk. No:8 41190 Başiskele/Kocaeli</p> <p>info@dssotomasyon.com.tr</p> <p>+90 544 322 23 10</p>		<p><b>PROJE ADI</b></p> <p>PLC101 stoper</p>	<p><b>SAYFA AÇIKLAMASI</b></p> <p>-VA2-V399</p>	<p>Çizen: Hasancan Simen</p> <p>Kontrol Eden: Sabri Ebrem</p>	<p>Sayfa 5</p> <p>T. Sayfa 72 / 167</p>
		<p><b>++VA2</b></p>	<p><b>+</b></p>		

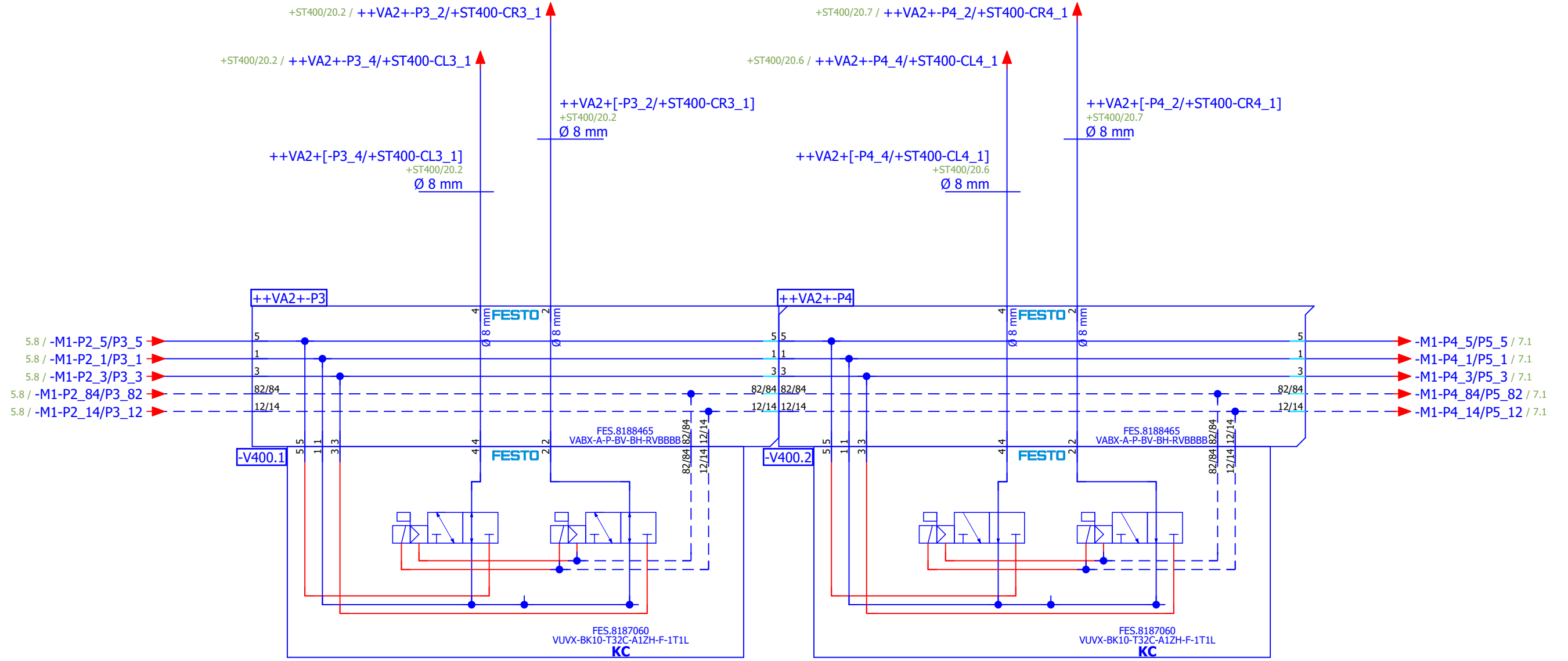

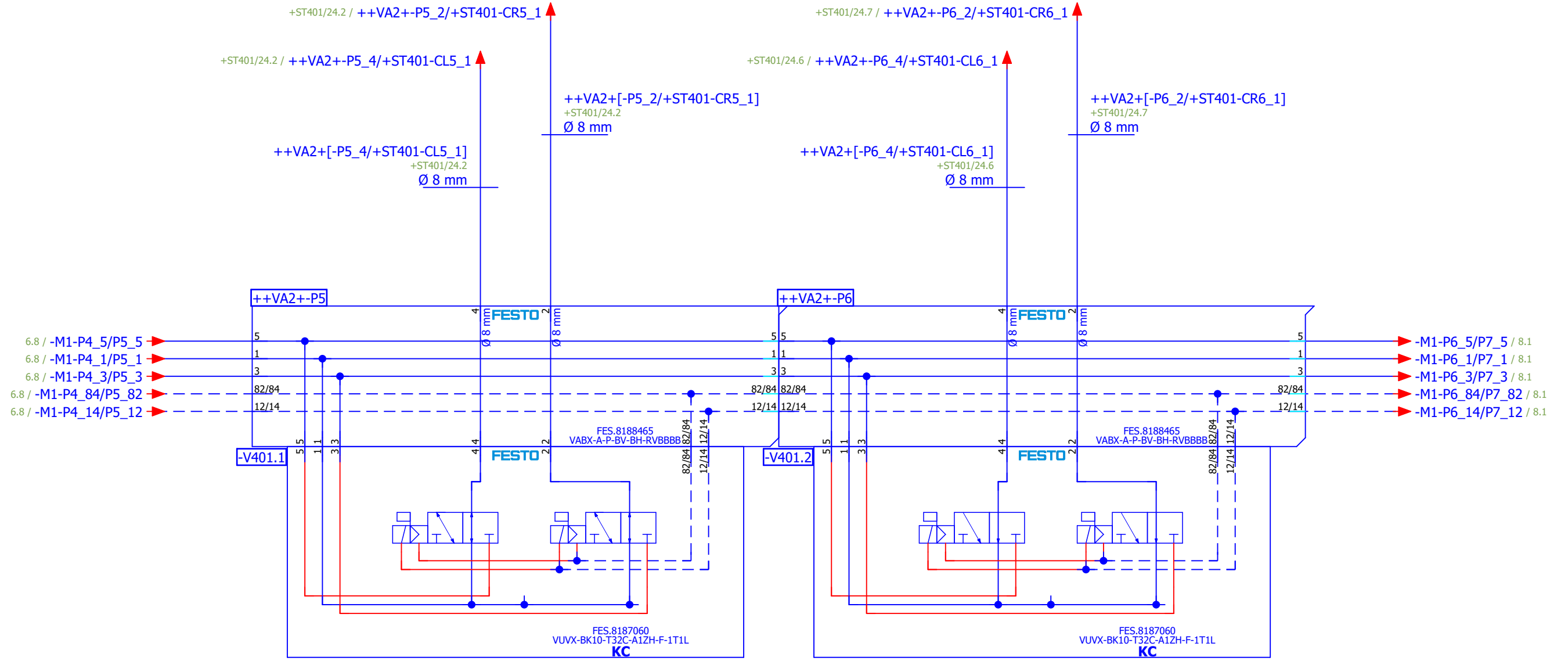

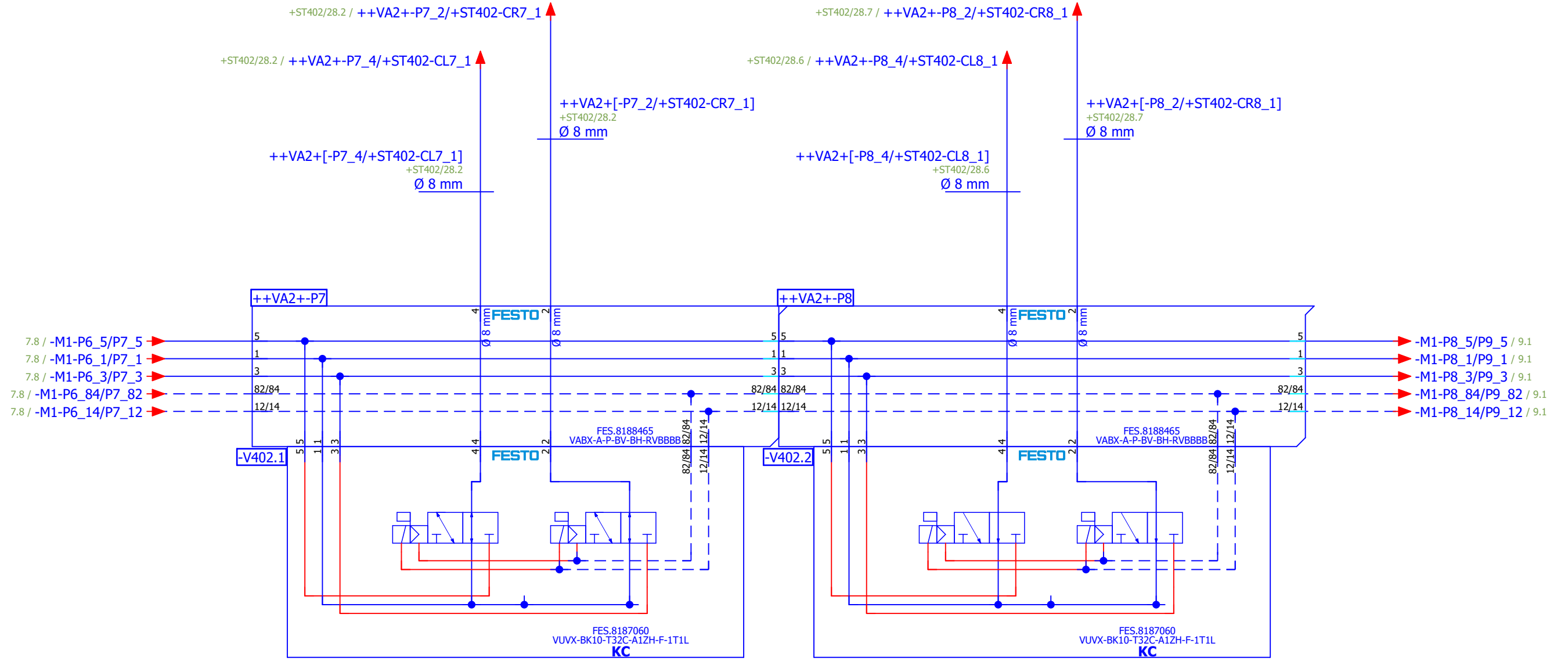

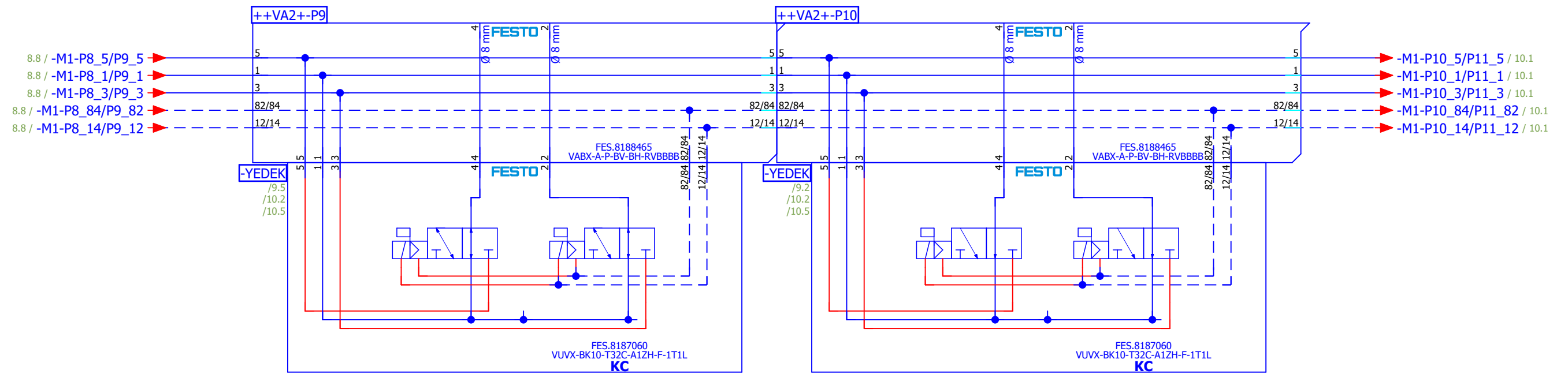

<p>Yeşilyurt, Muhtar Cafer Sk. No:8 41190 Başiskele/Kocaeli</p> <p>info@dssotomasyon.com.tr</p> <p>+90 544 322 23 10</p>		<p><b>PROJE ADI</b></p> <p>PLC101 stoper</p>	<p><b>SAYFA AÇIKLAMASI</b></p> <p>-VA2-V402</p>	<p>Çizen: Hasancan Simen</p> <p>Kontrol Eden: Sabri Ebrem</p>	<p>Sayfa 8</p> <p>T. Sayfa 75 / 167</p>
		<p><b>++VA2</b></p>	<p><b>+</b></p>		

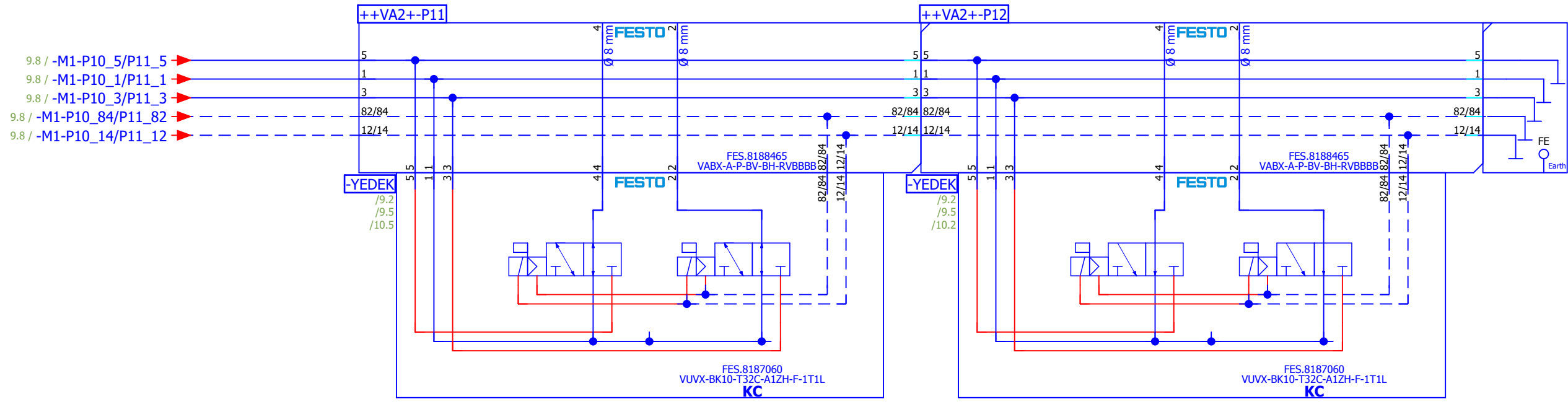



	Yeşilyurt, Muhtar Cafer Sk. No:8 41190 Başiskele/Kocaeli		<b>PROJE ADI</b>	<b>SAYFA AÇIKLAMASI</b>	Çizen: Hasancan Simen	Sayfa 10
	info@dssotomasyon.com.tr		PLC101 stoper	-VA2-YEDEK	Kontrol Eden: Sabri Ebrem	++VA2
	+90 544 322 23 10					+

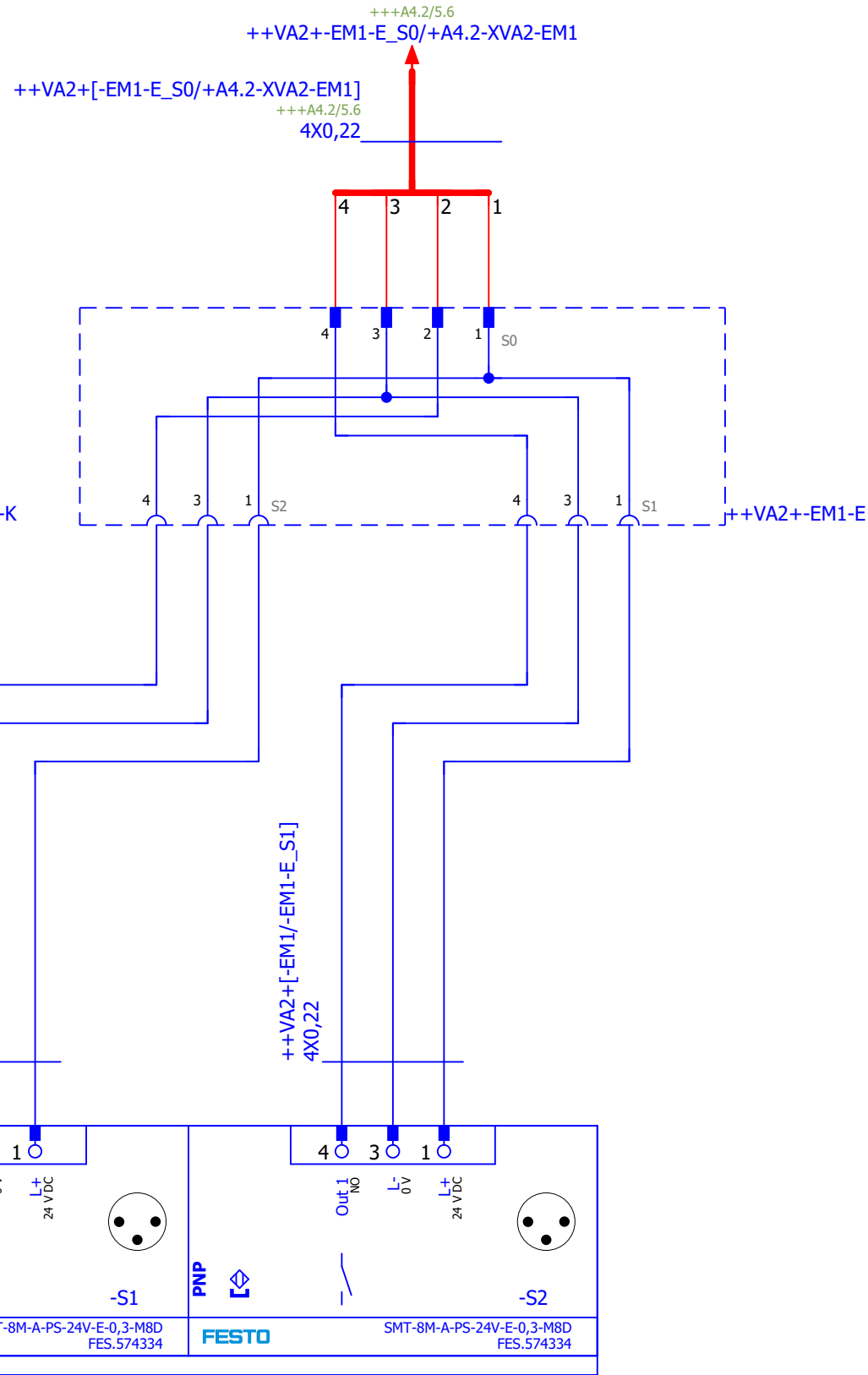
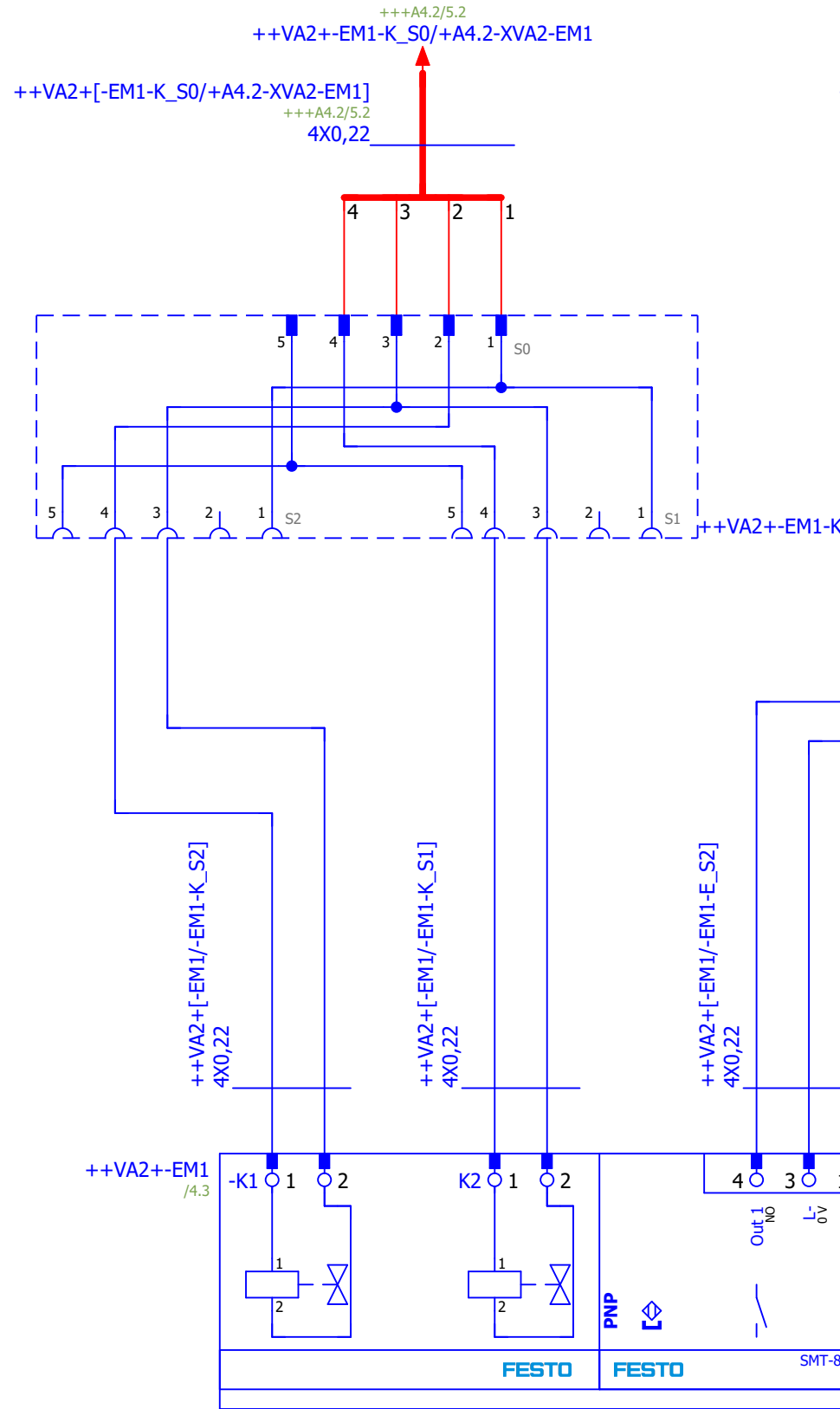
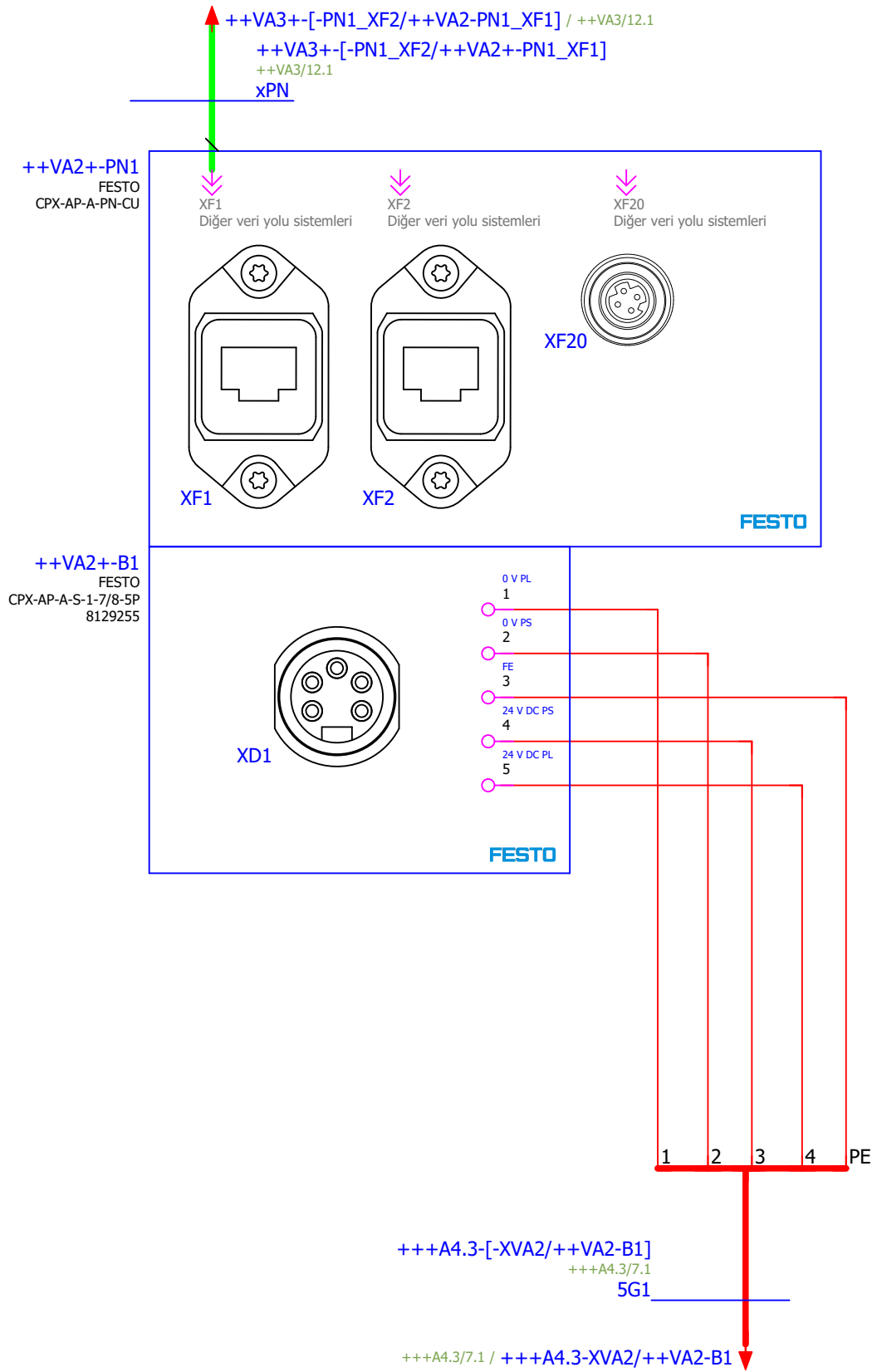

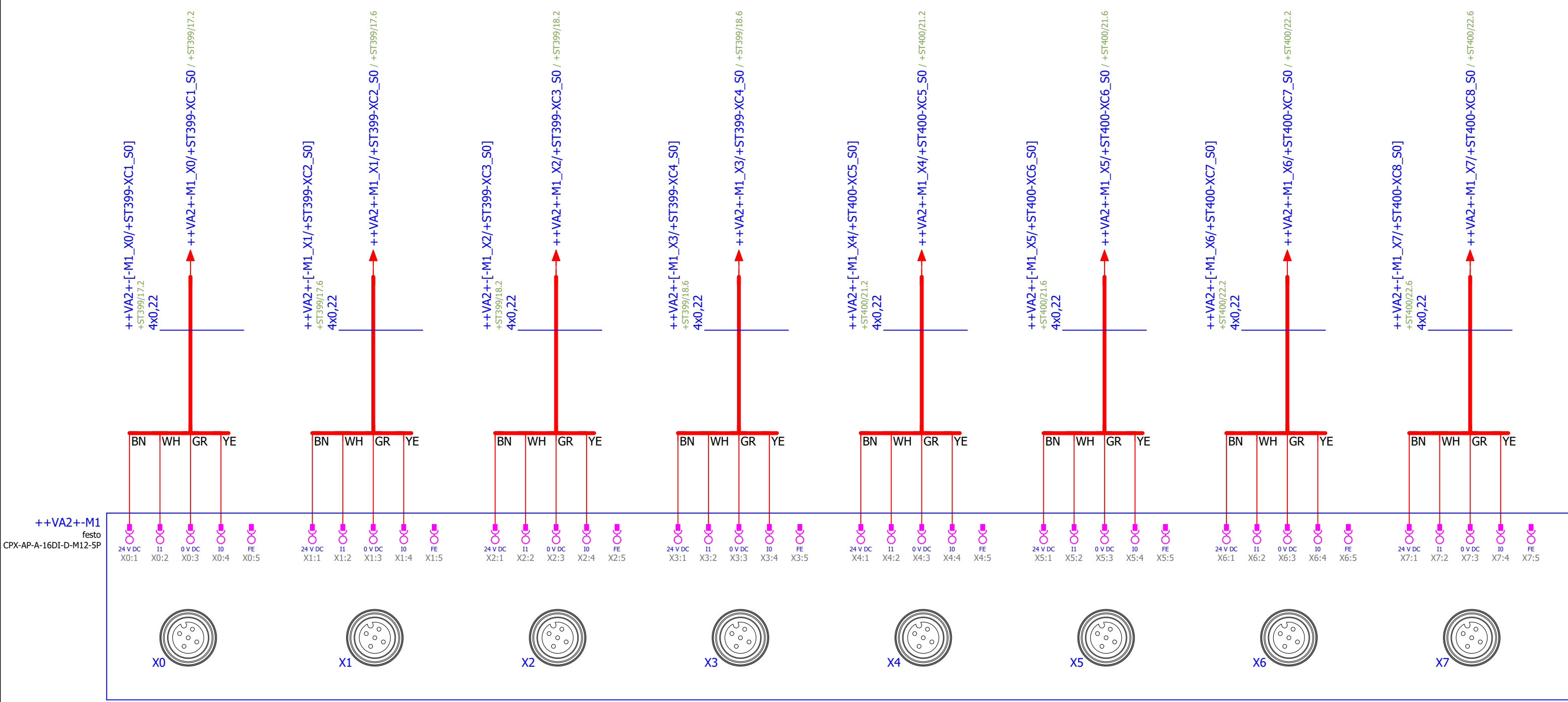

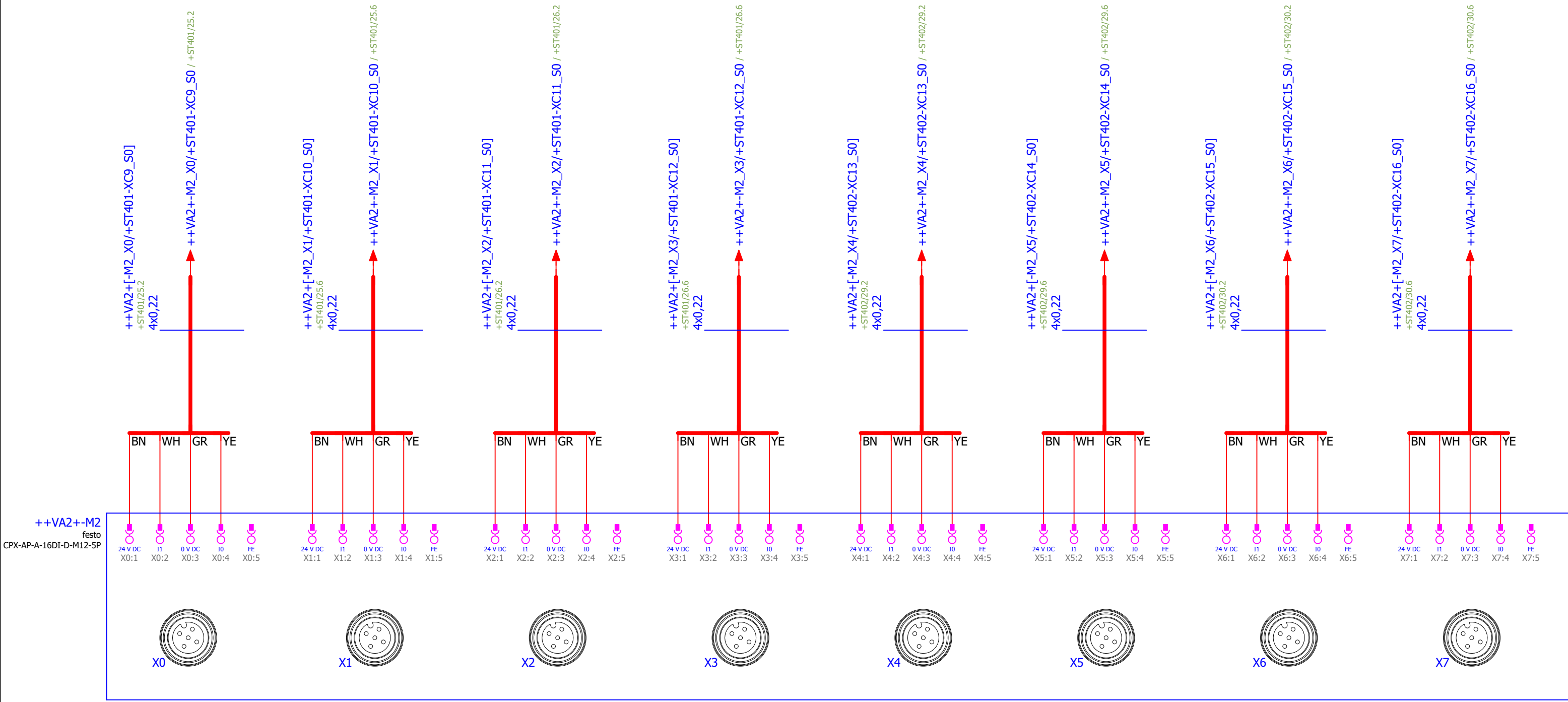

++VA2+-M3  
festo

CPX-AP-A-16DI-D-M12-5P

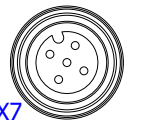
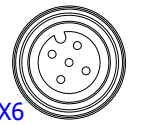
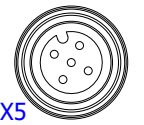
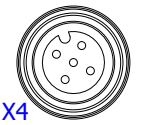
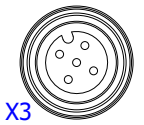
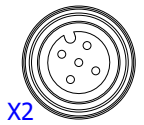
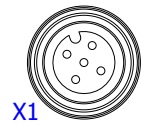
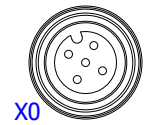
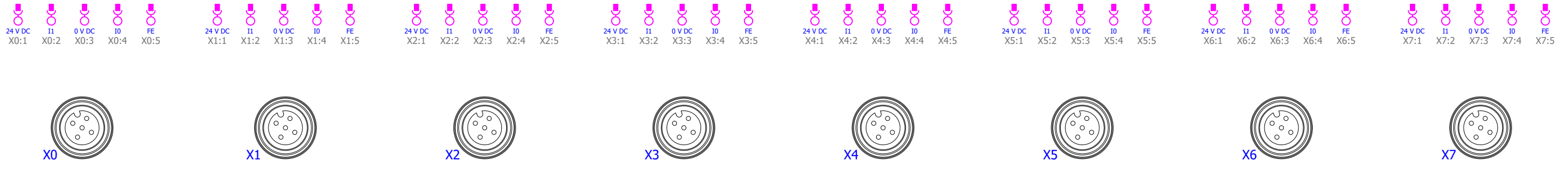

X0

X1

X2

X3

X4

X5

X6

X7





Müşteri : FORD OTOSAN

Üretici (şirket) : DSS OTOMASYON

+ST399



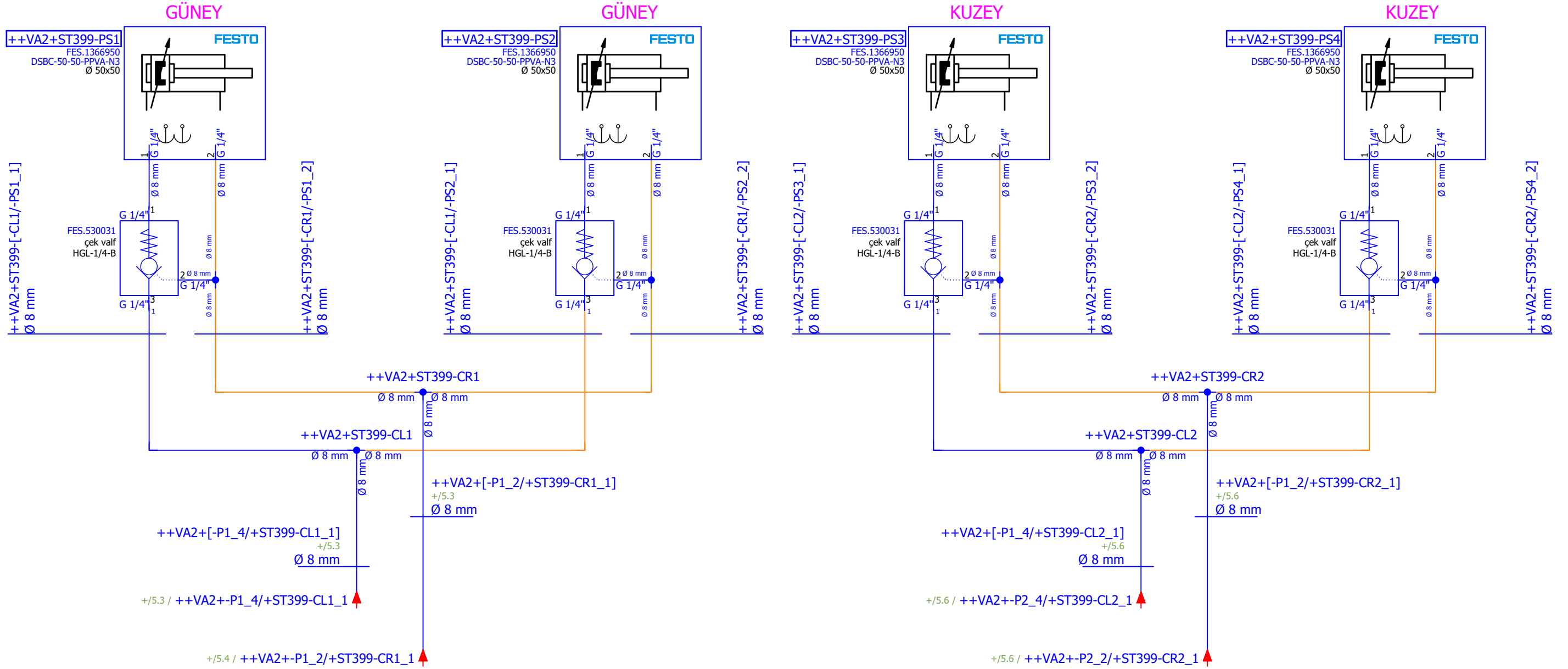

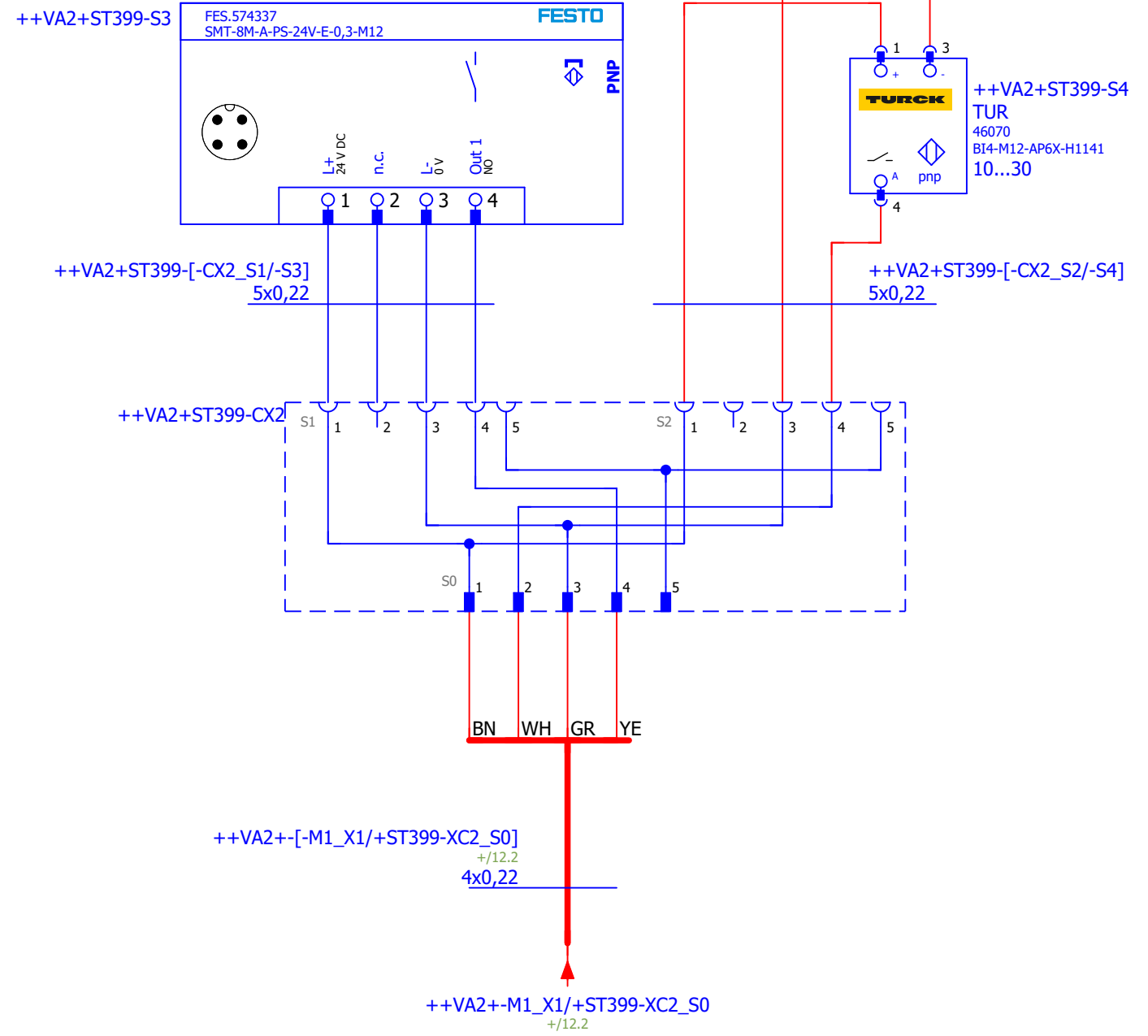
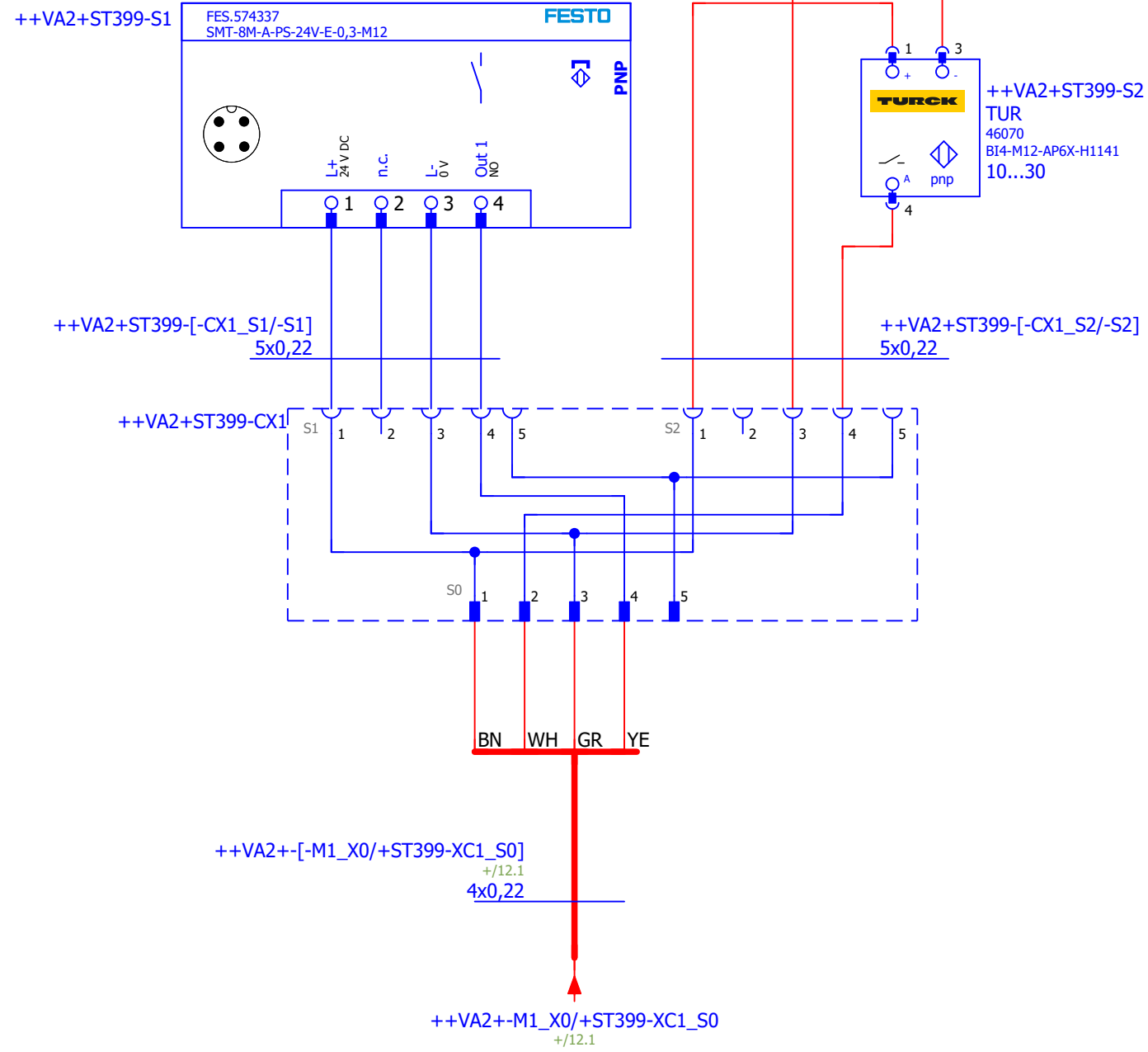

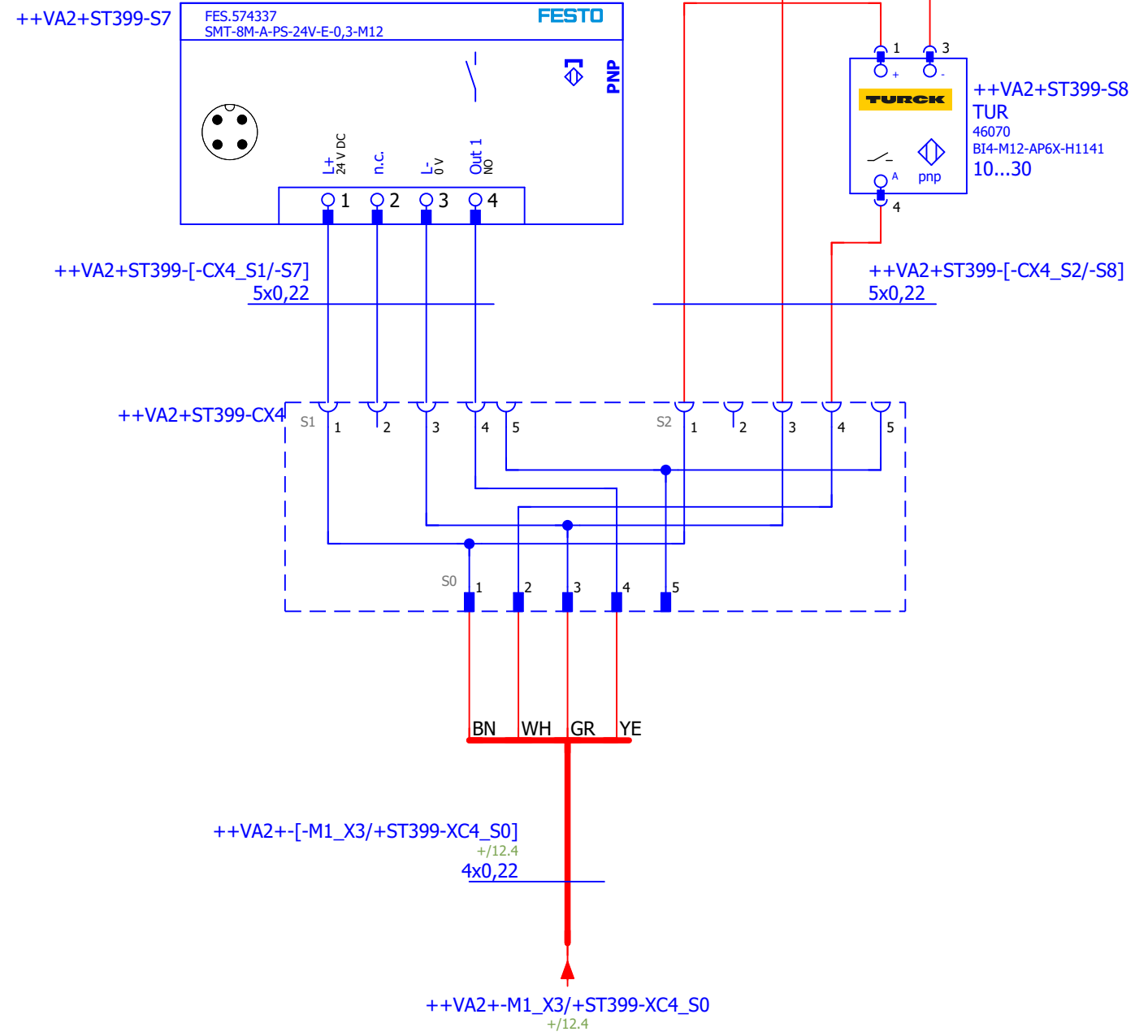
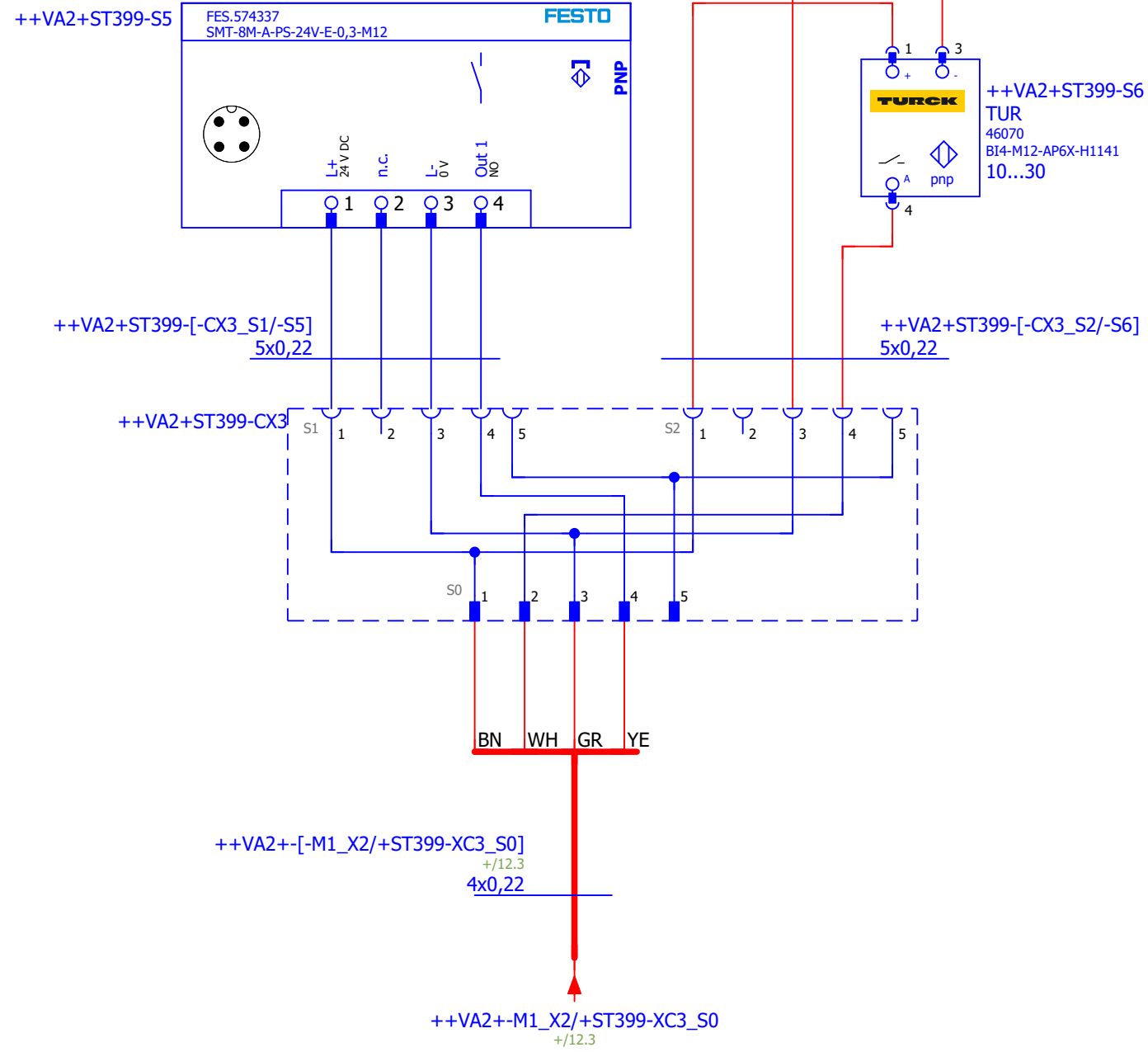

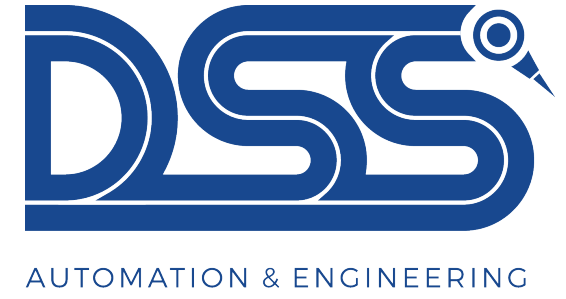

Müşteri : FORD OTOSAN

Üretici (şirket) : DSS OTOMASYON

+ST400



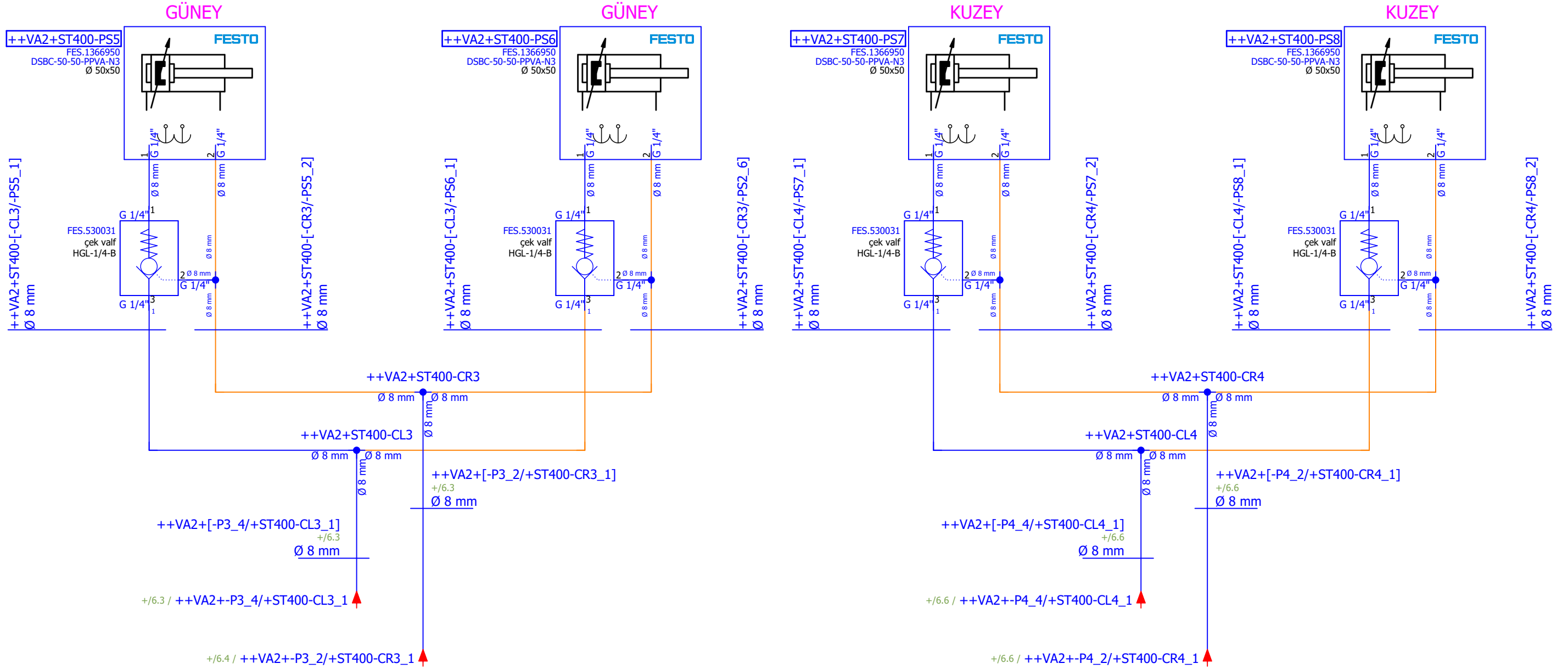

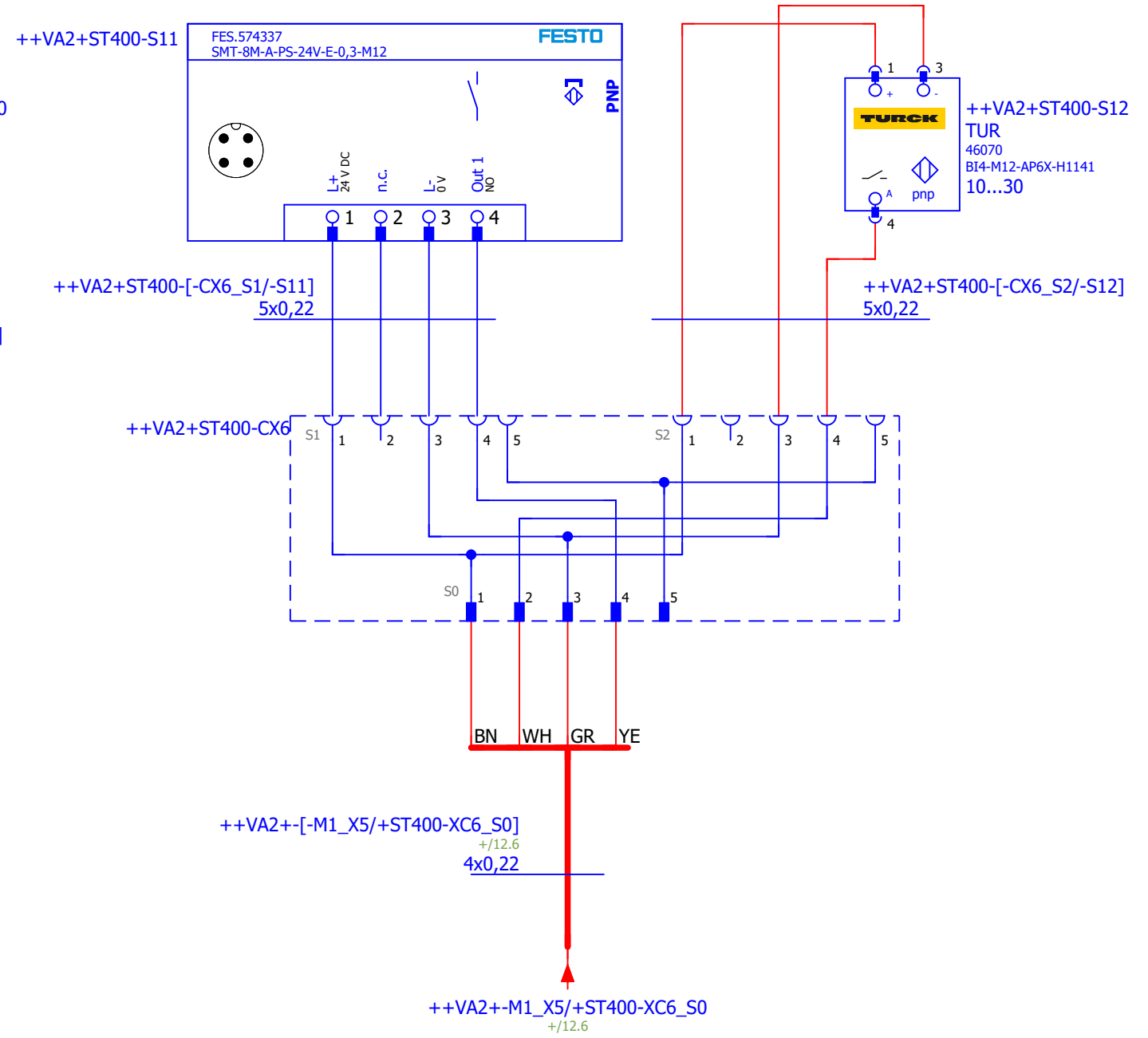
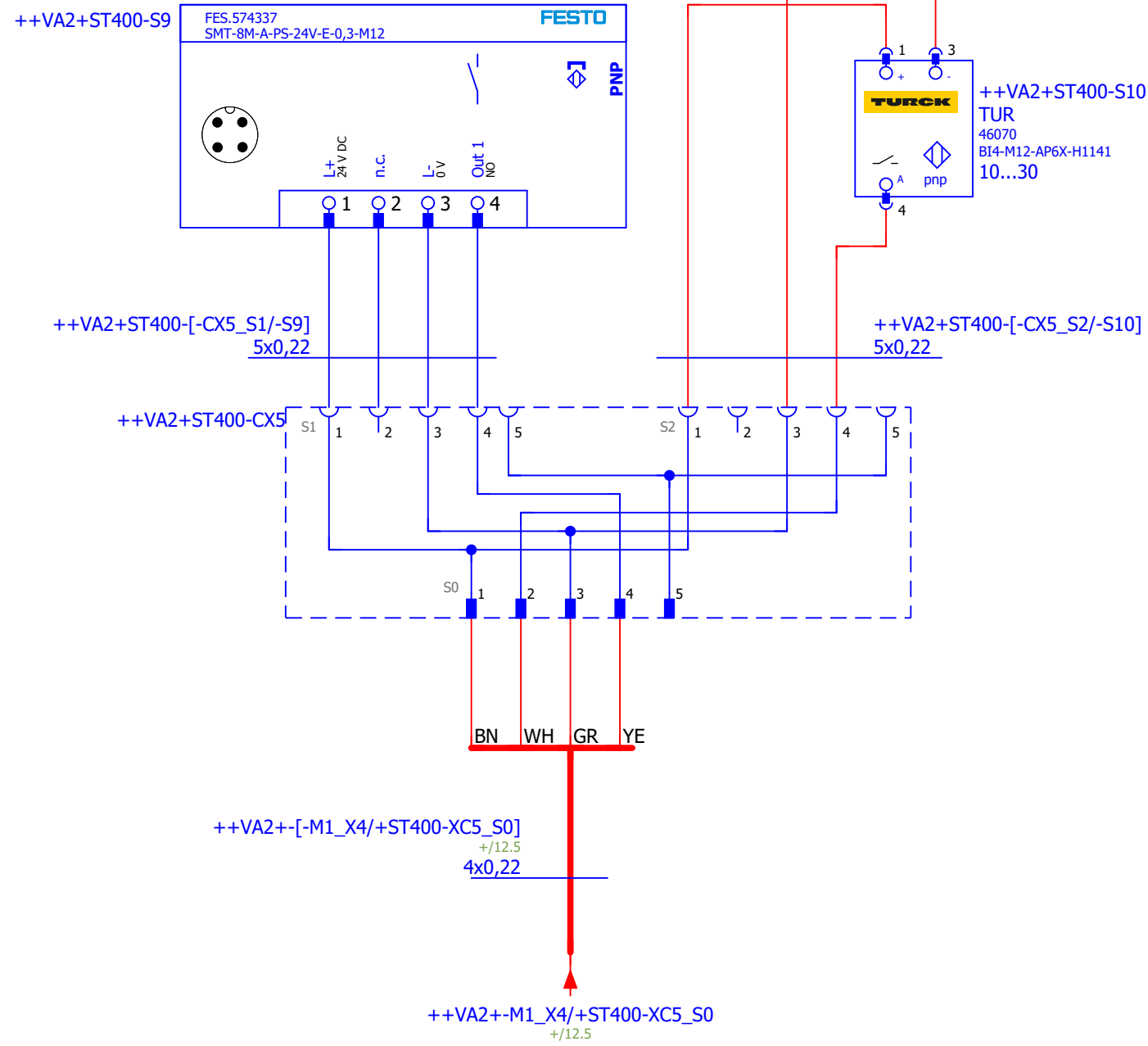

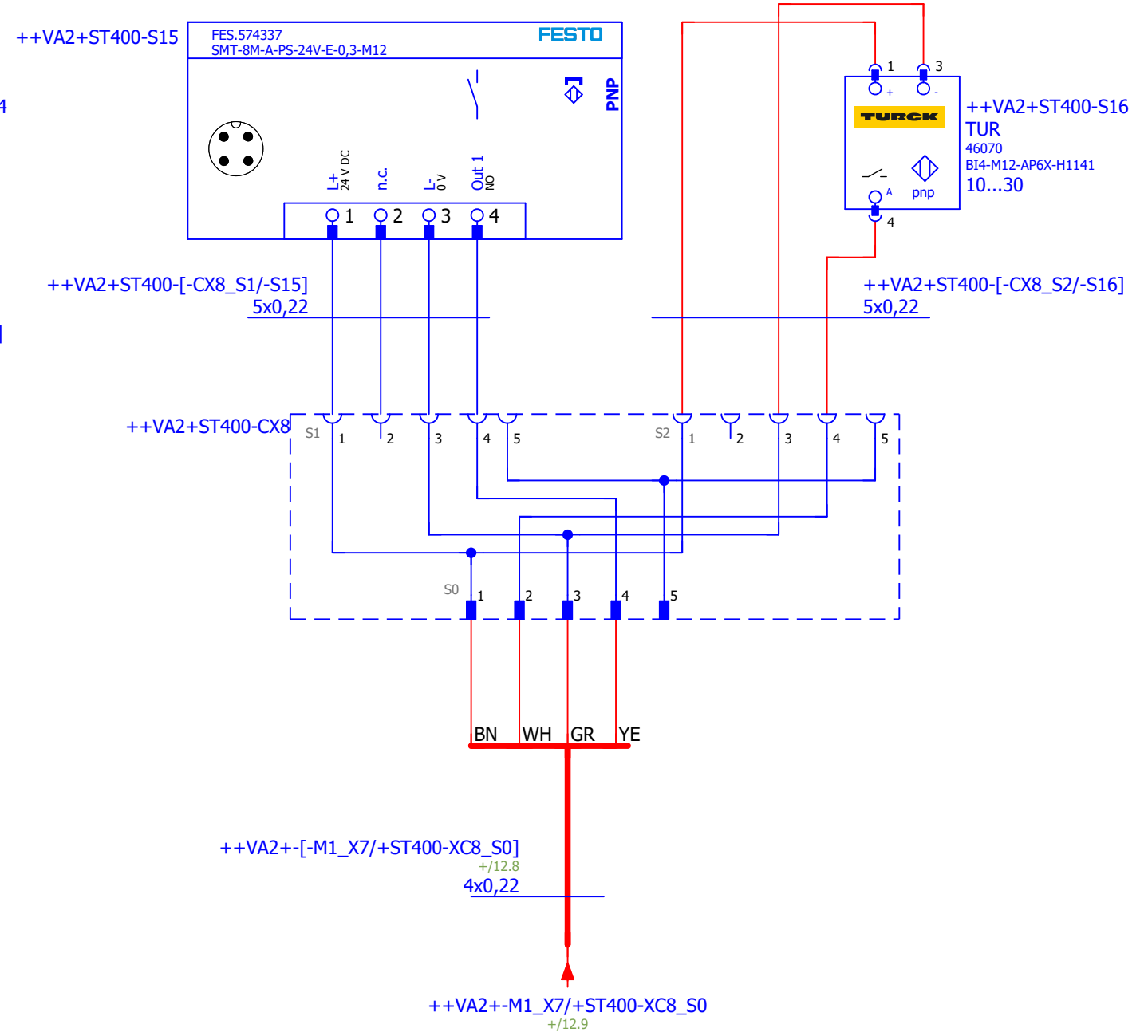
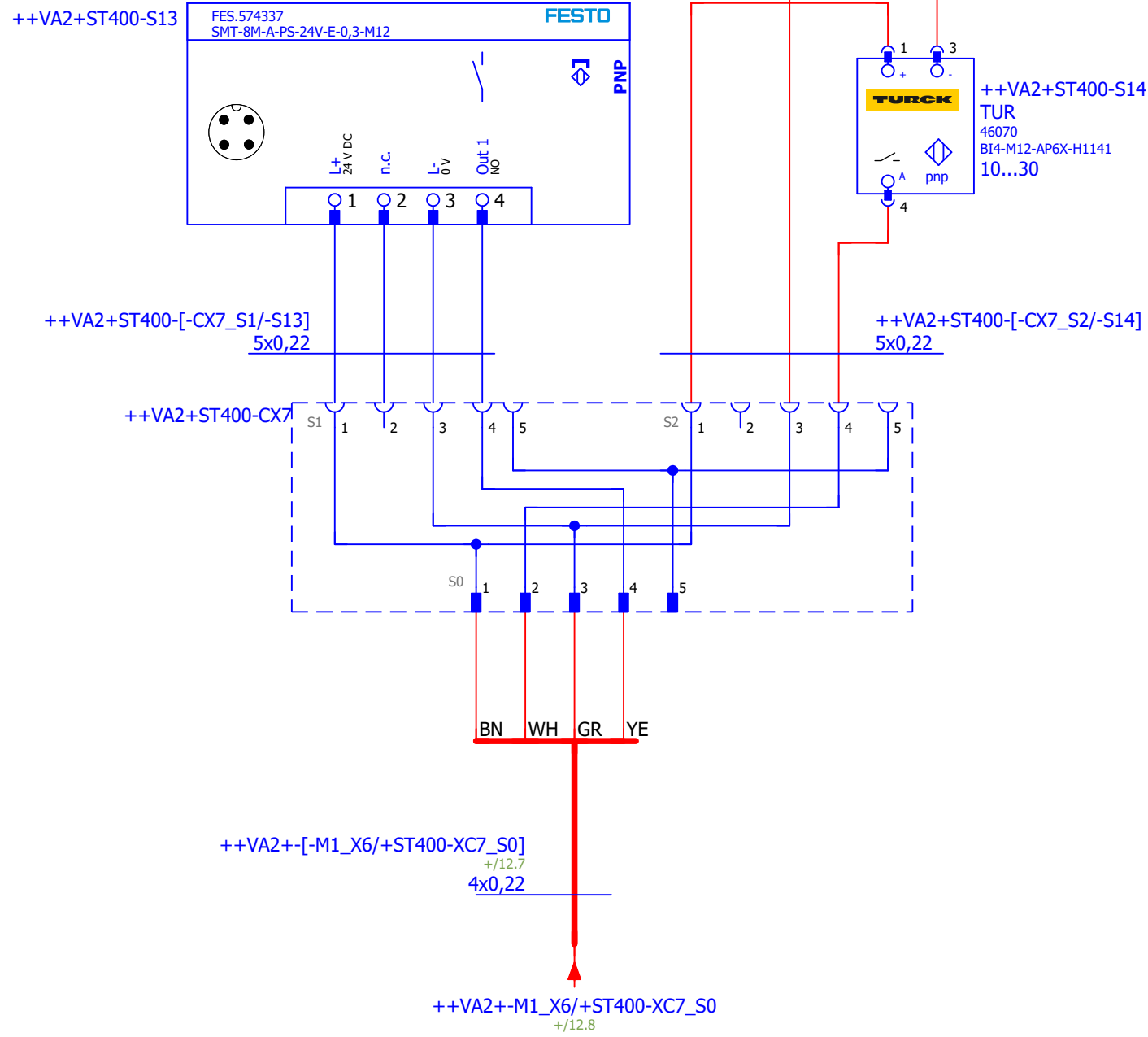

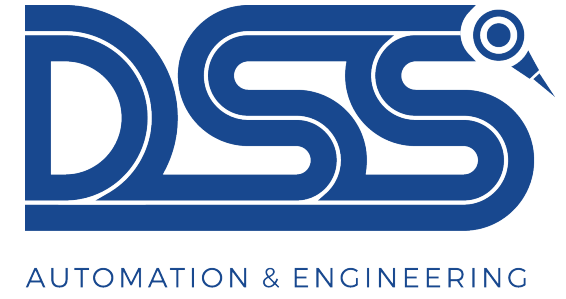

Müşteri : FORD OTOSAN

Üretici (şirket) : DSS OTOMASYON

+ST401



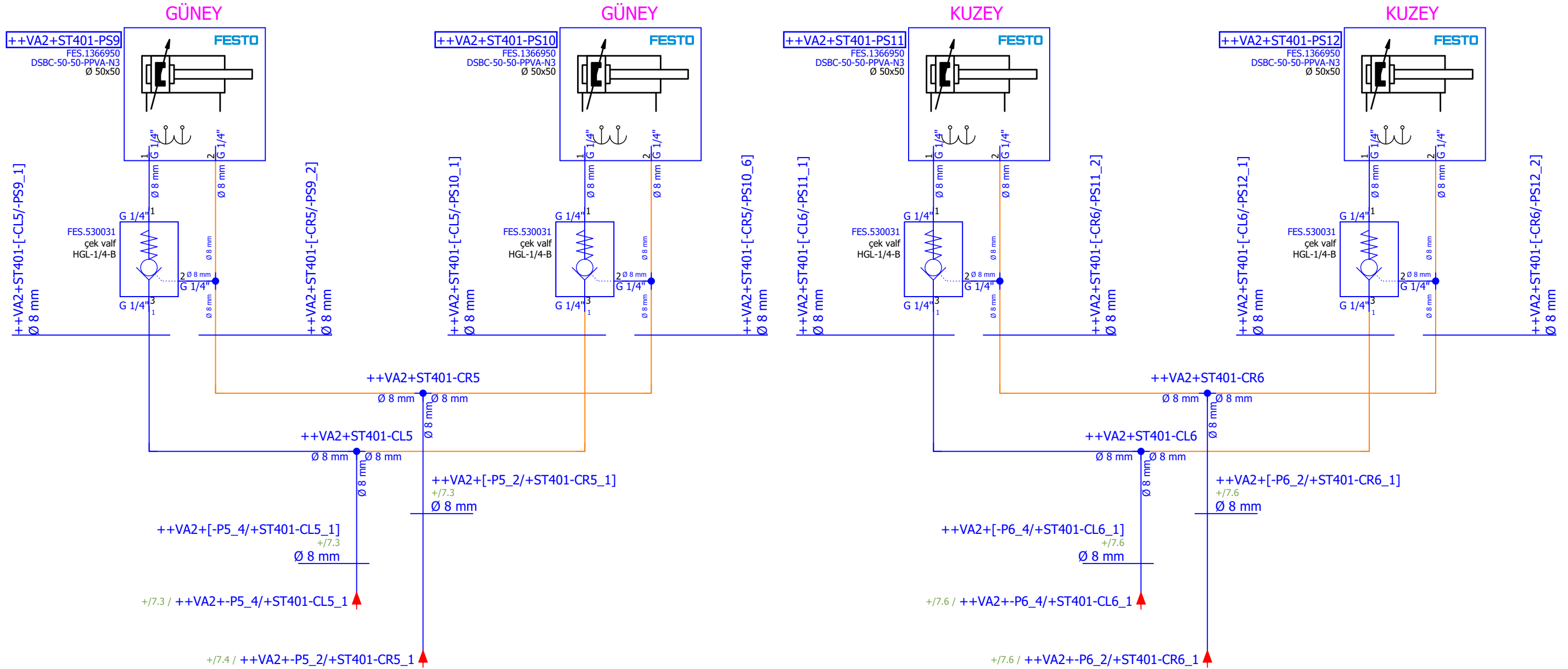

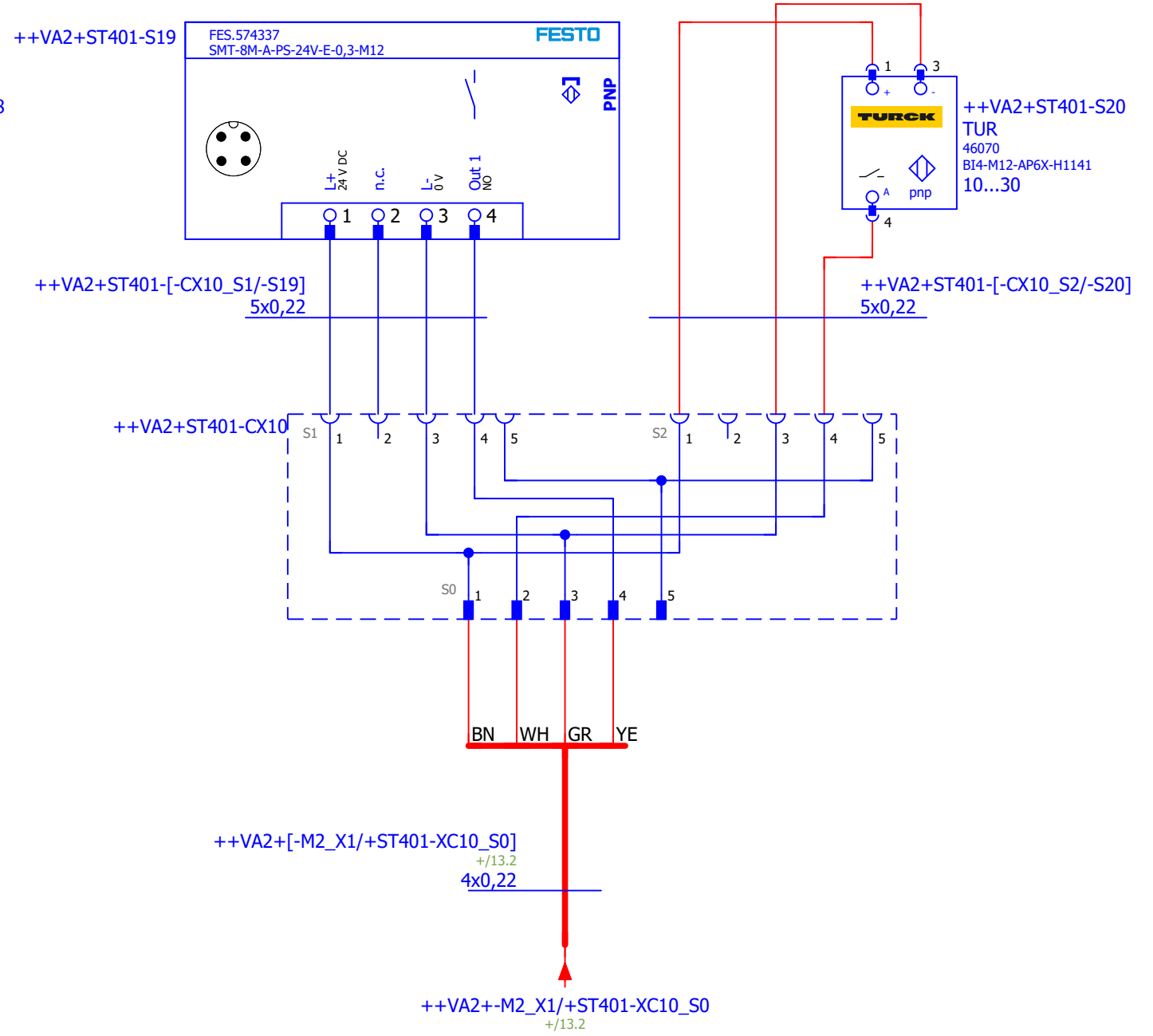
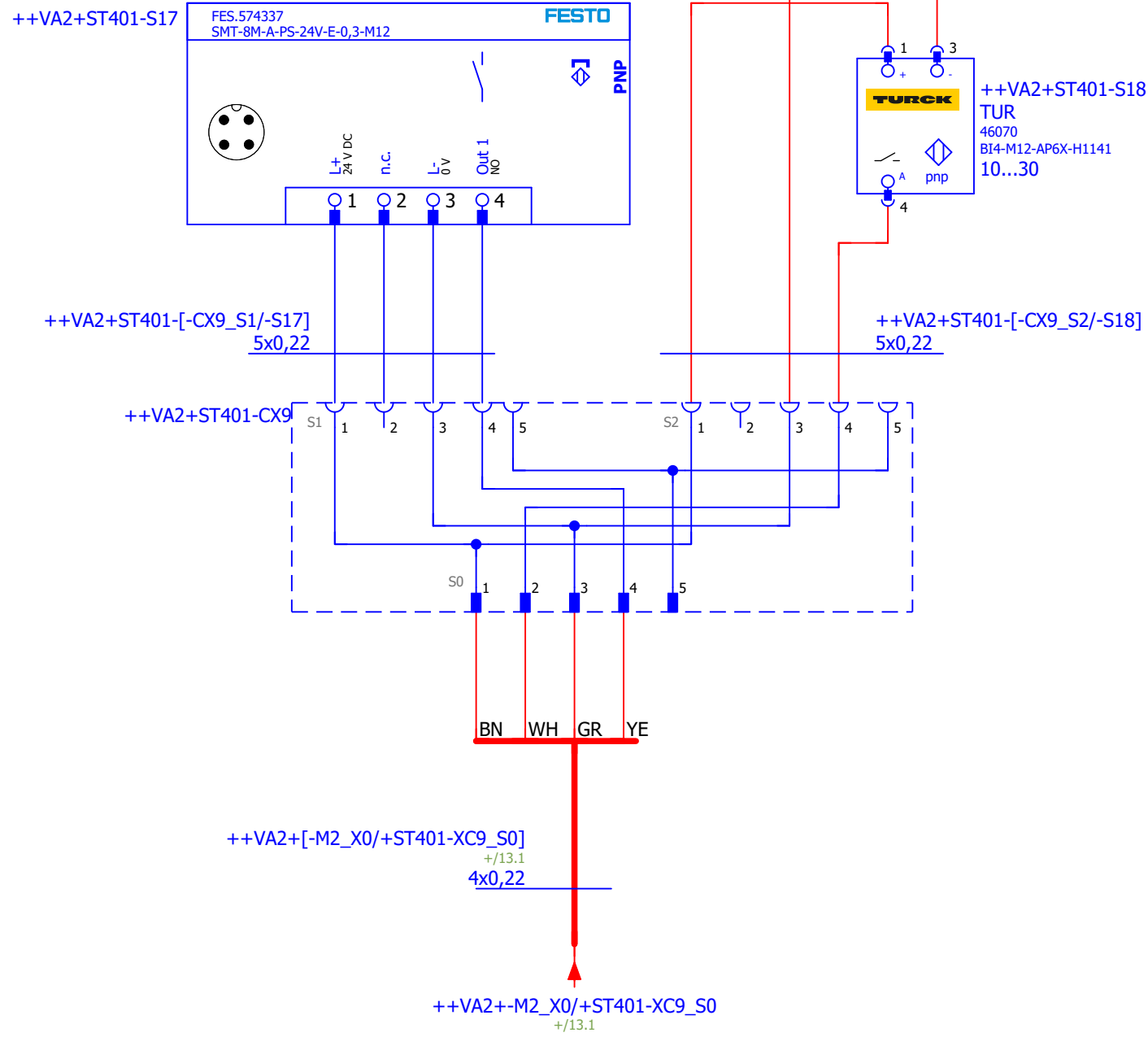

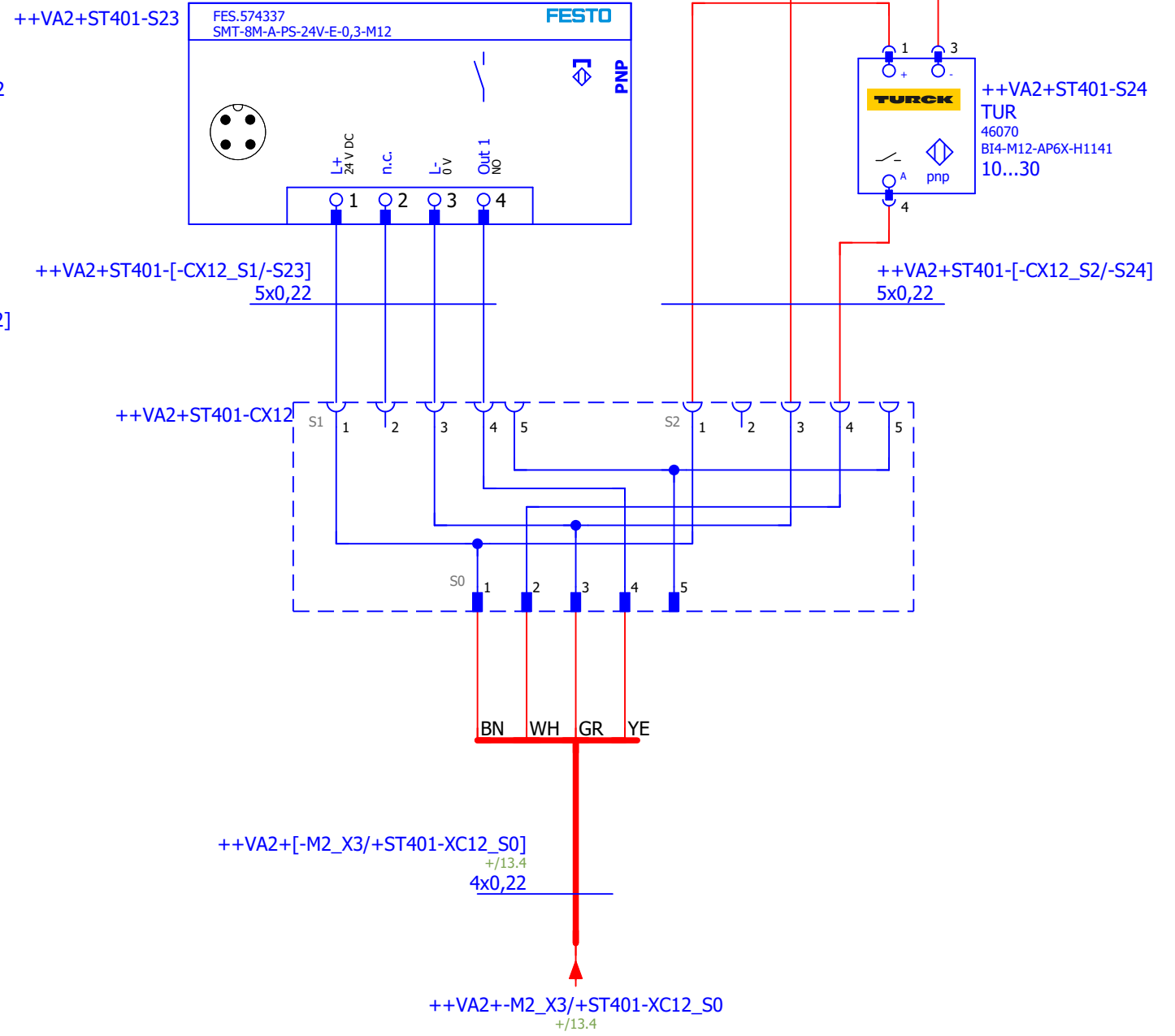
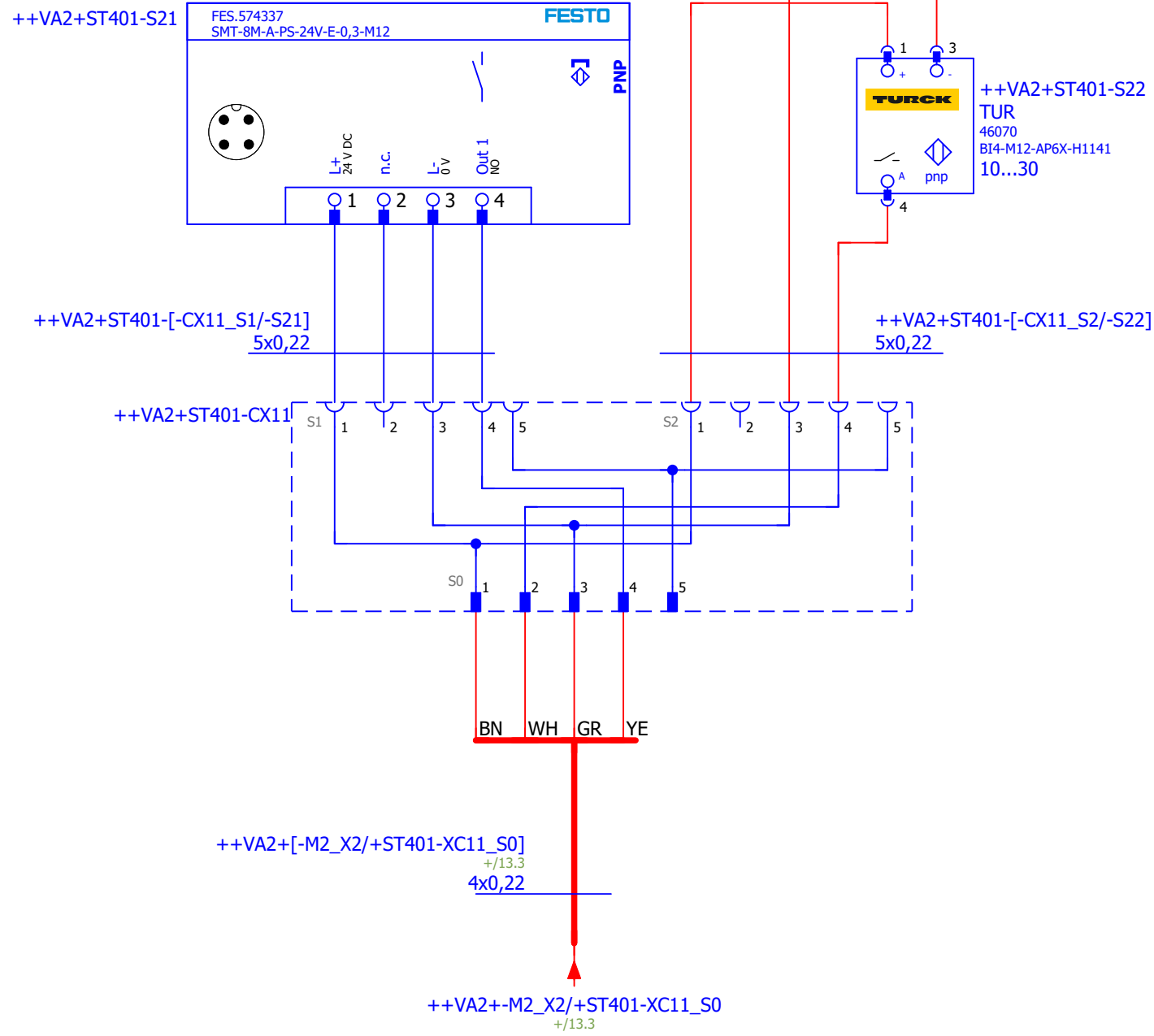

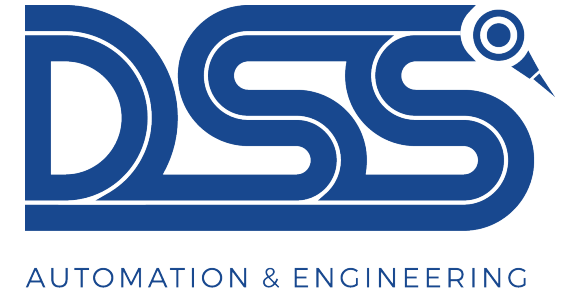

Müşteri : FORD OTOSAN

Üretici (şirket) : DSS OTOMASYON



+ST402

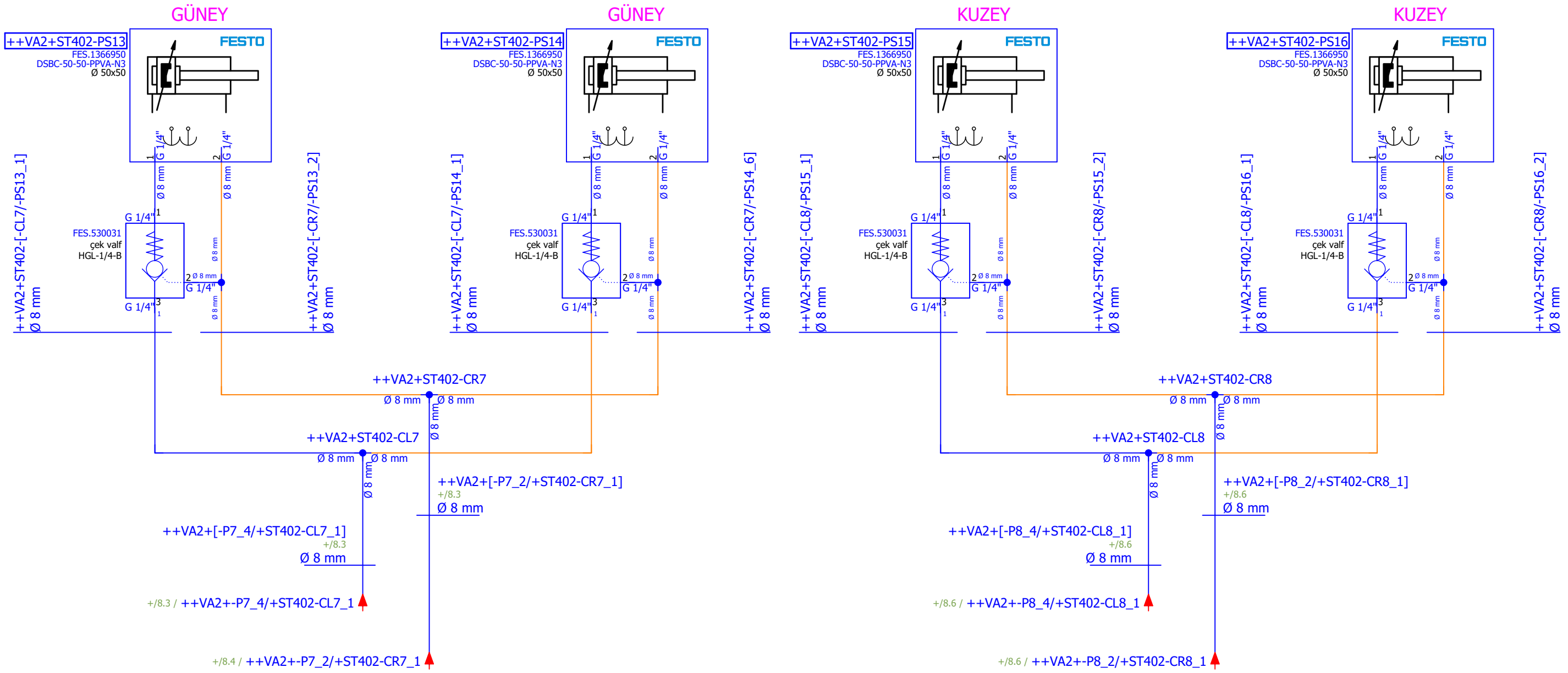

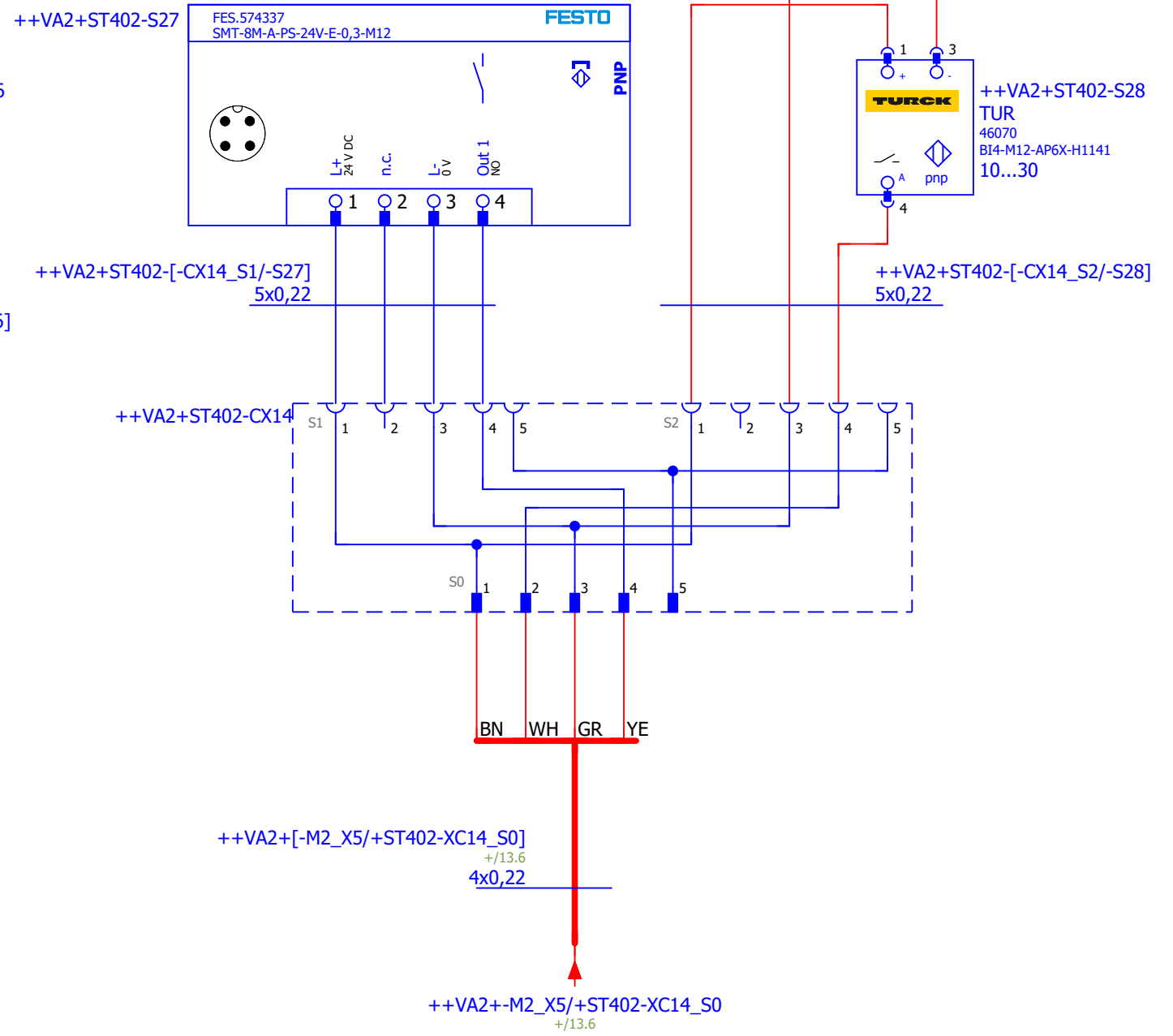
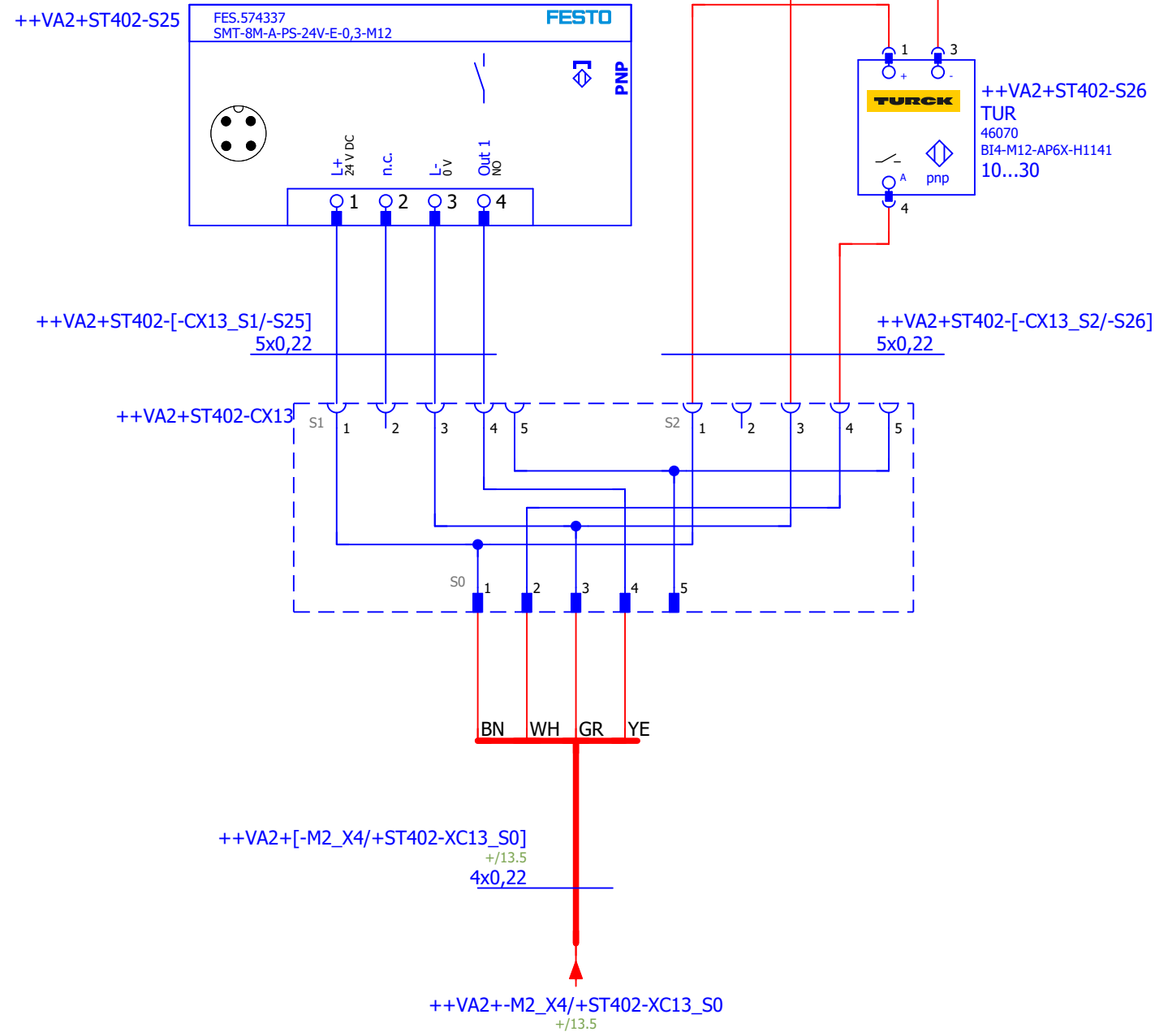

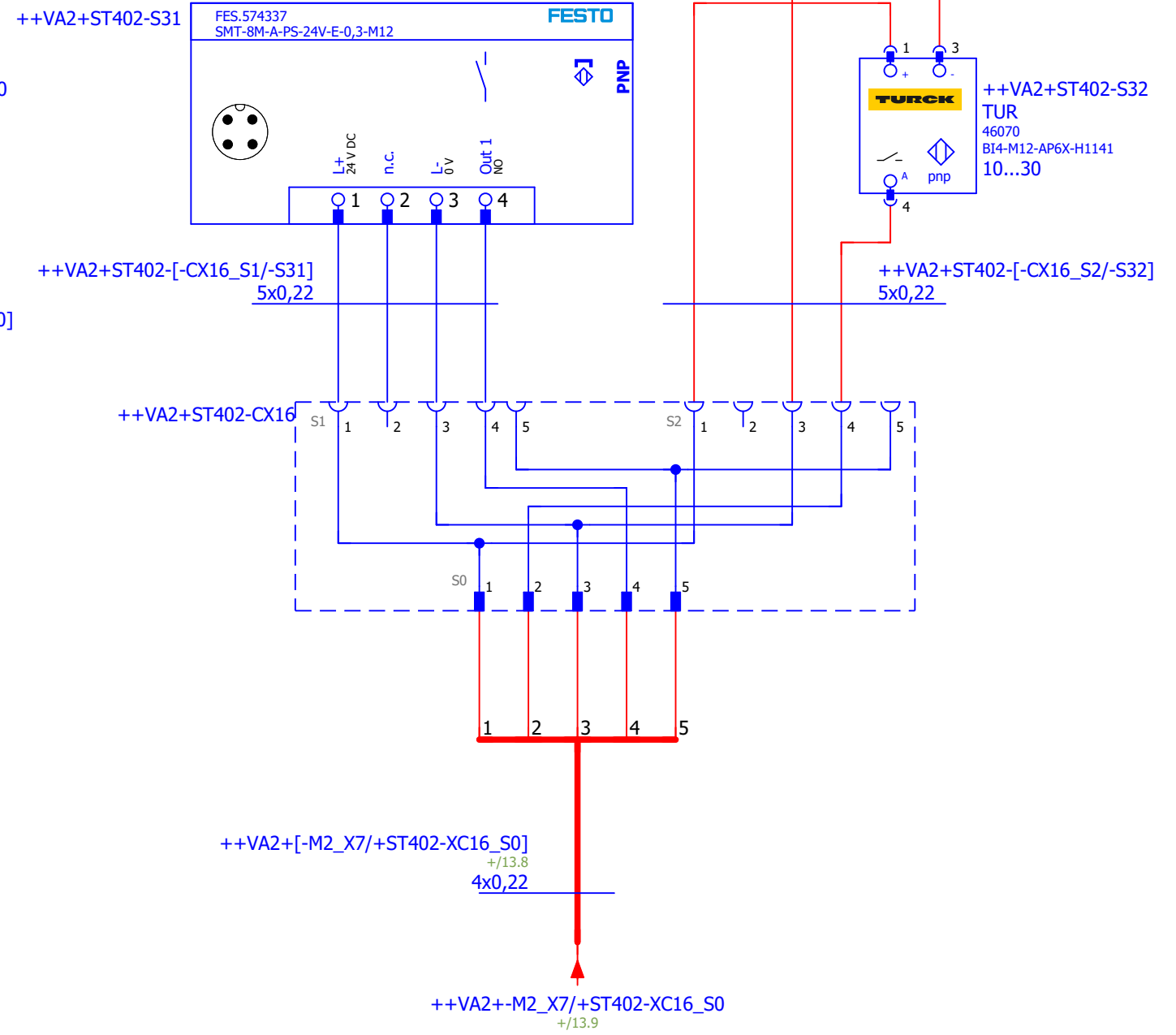
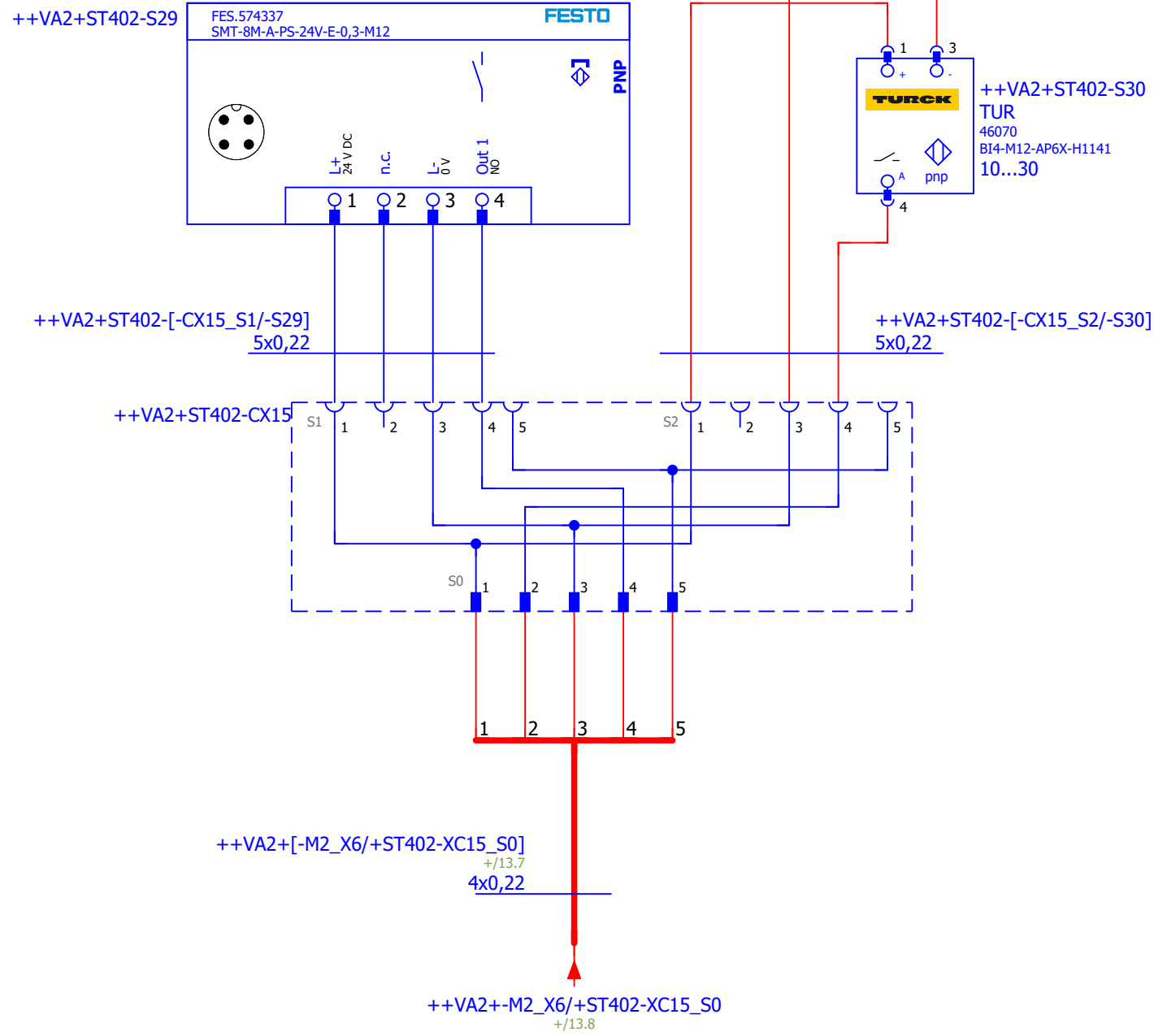



 <p>Yeşilyurt, Muhtar Cafer Sk. No:8 41190 Başiskele/Kocaeli</p> <p>info@dssotomasyon.com.tr</p> <p>+90 544 322 23 10</p>		<p><b>PROJE ADI</b></p> <p>PLC101 stoper</p>	<p><b>SAYFA AÇIKLAMASI</b></p> <p>SENSÖRLER</p>	<p>Çizen: Hasancan Simen</p> <p>Kontrol Eden: Sabri Ebrem</p>	<p>Sayfa 30</p>
		<p>++VA2</p> <p>+ST402</p>	<p>T. Sayfa 97 / 167</p>		

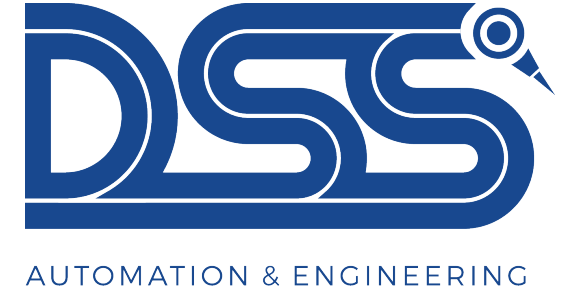

Müşteri : FORD OTOSAN

Üretici (şirket) : DSS OTOMASYON

++VA3



	Yeşilyurt, Muhtar Cafer Sk. No:8 41190 Başiskele/Kocaeli		<b>PROJE ADI</b>	<b>SAYFA AÇIKLAMASI</b>	Çizen: Hasancan Simen	Sayfa 1
	info@dssotomasyon.com.tr		PLC101 stoper	KAPAK	Kontrol Eden: Sabri Ebrem	++VA3
	+90 544 322 23 10					+

KUZEY

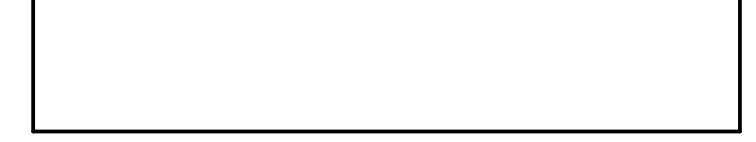
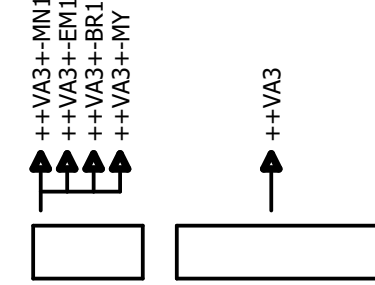
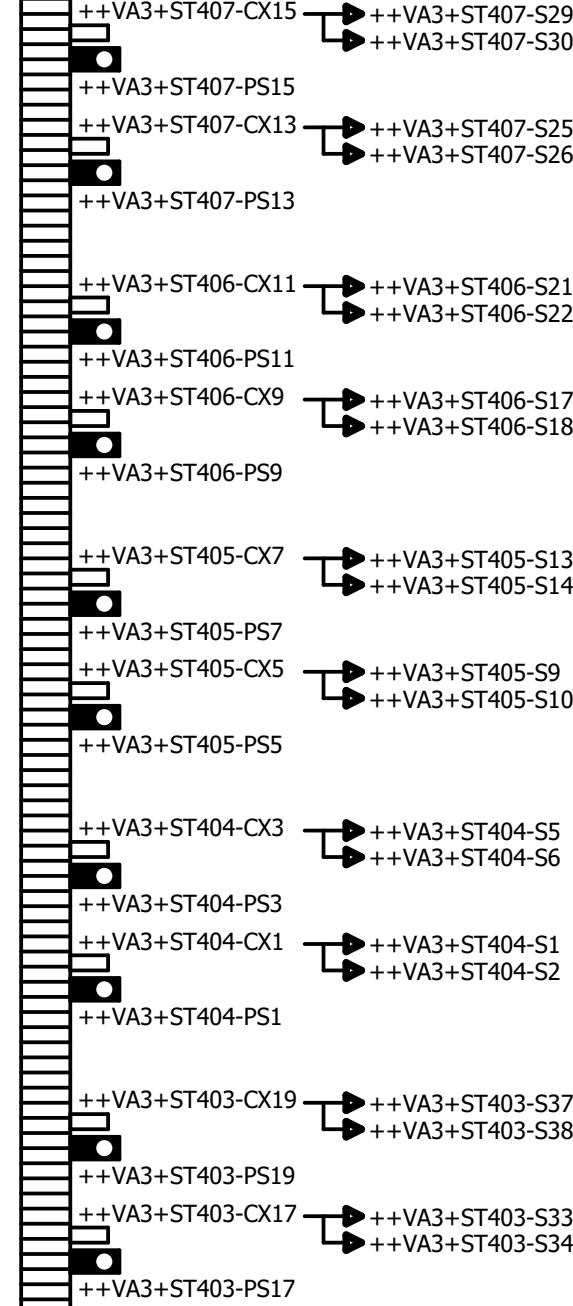
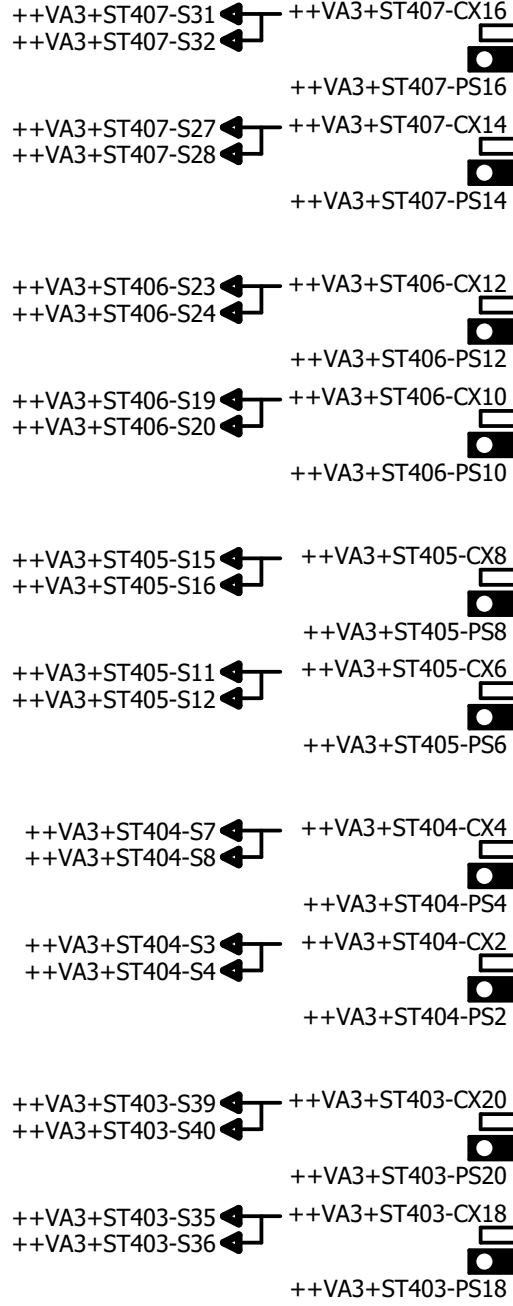

GÜNEY



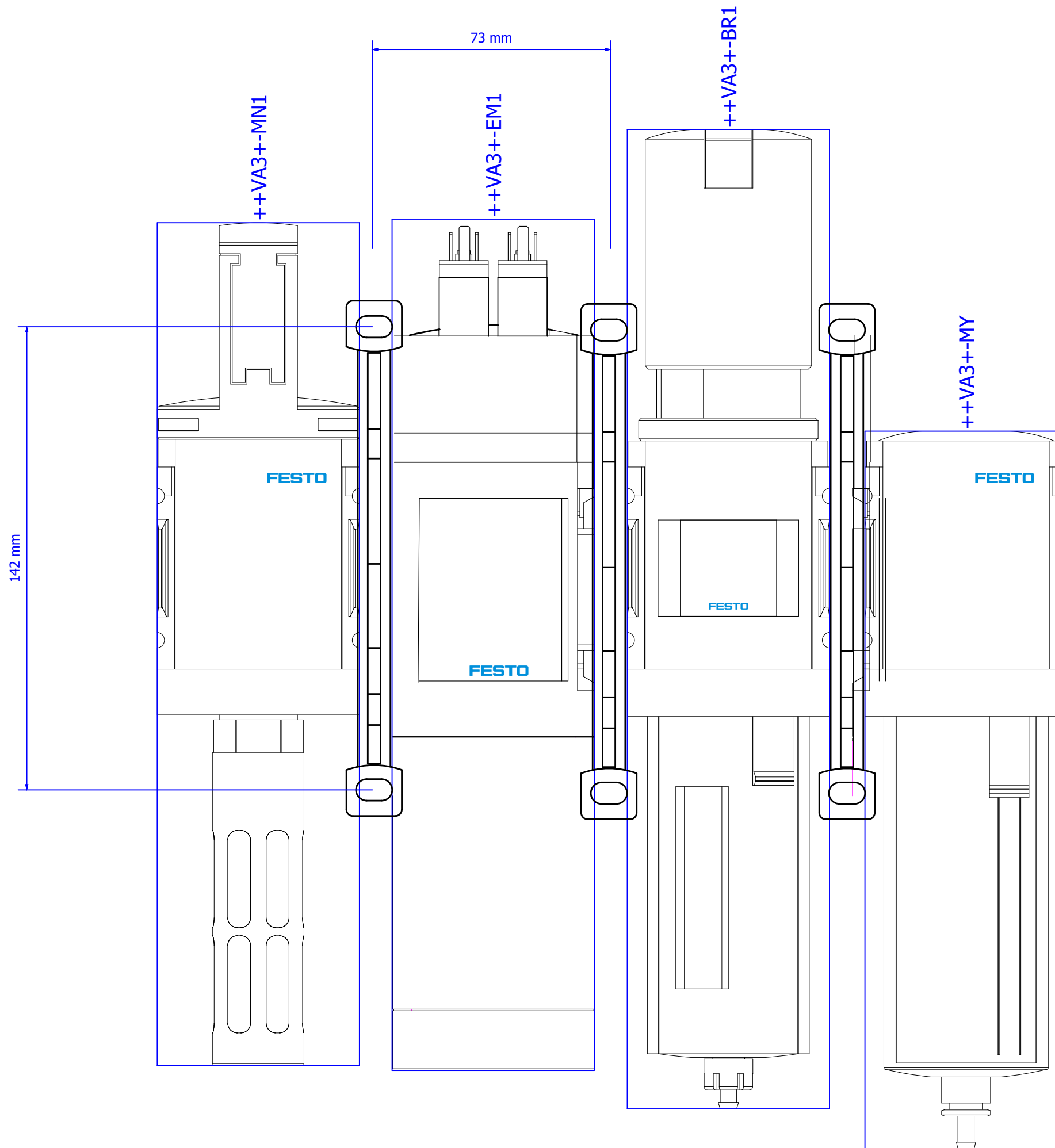

3



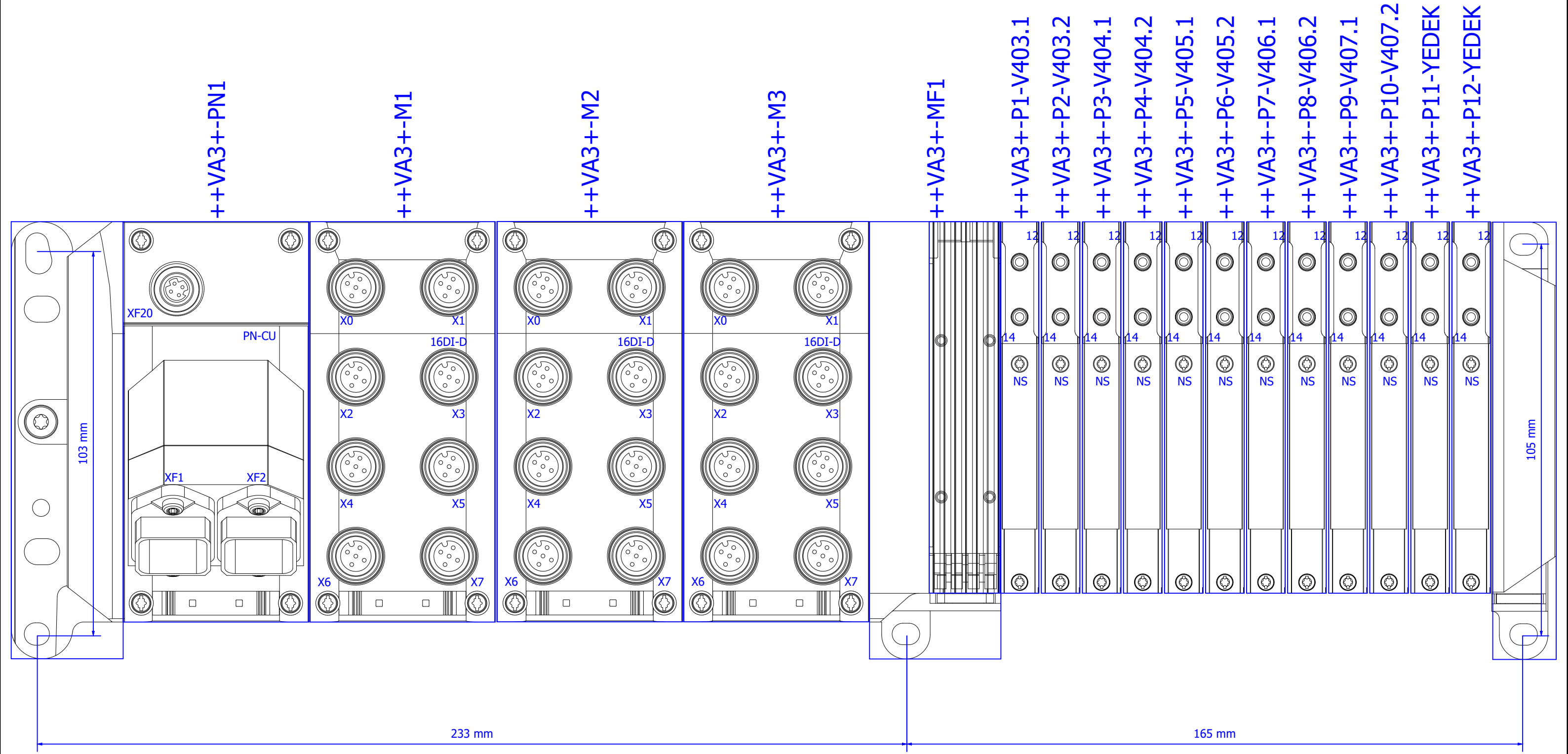

	Yeşilyurt, Muhtar Cafer Sk. No:8 41190 Başiskele/Kocaeli		<b>PROJE ADI</b> PLC101 stoper	<b>SAYFA AÇIKLAMASI</b> MOTAJ PLAKASI	Çizen: Hasancan Simen Kontrol Eden: Sabri Ebrem	++VA3 +	Sayfa 4 T. Sayfa 101 / 167
	info@dssotomasyon.com.tr +90 544 322 23 10						

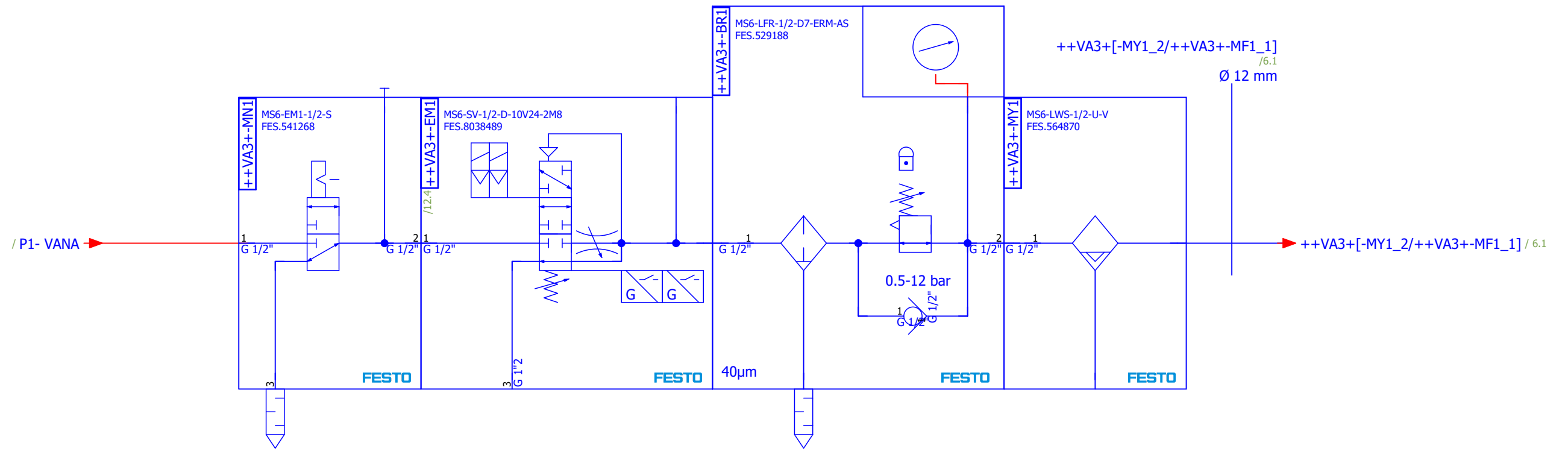

<b>PROJE ADI</b>	PLC101 stoper
------------------	---------------

<b>SAYFA AÇIKLAMASI</b>	ŞARTLANDIRICI
-------------------------	---------------

Çizen:	Hasancan Simen
Kontrol Eden:	Sabri Ebrem

++VA3	
+	

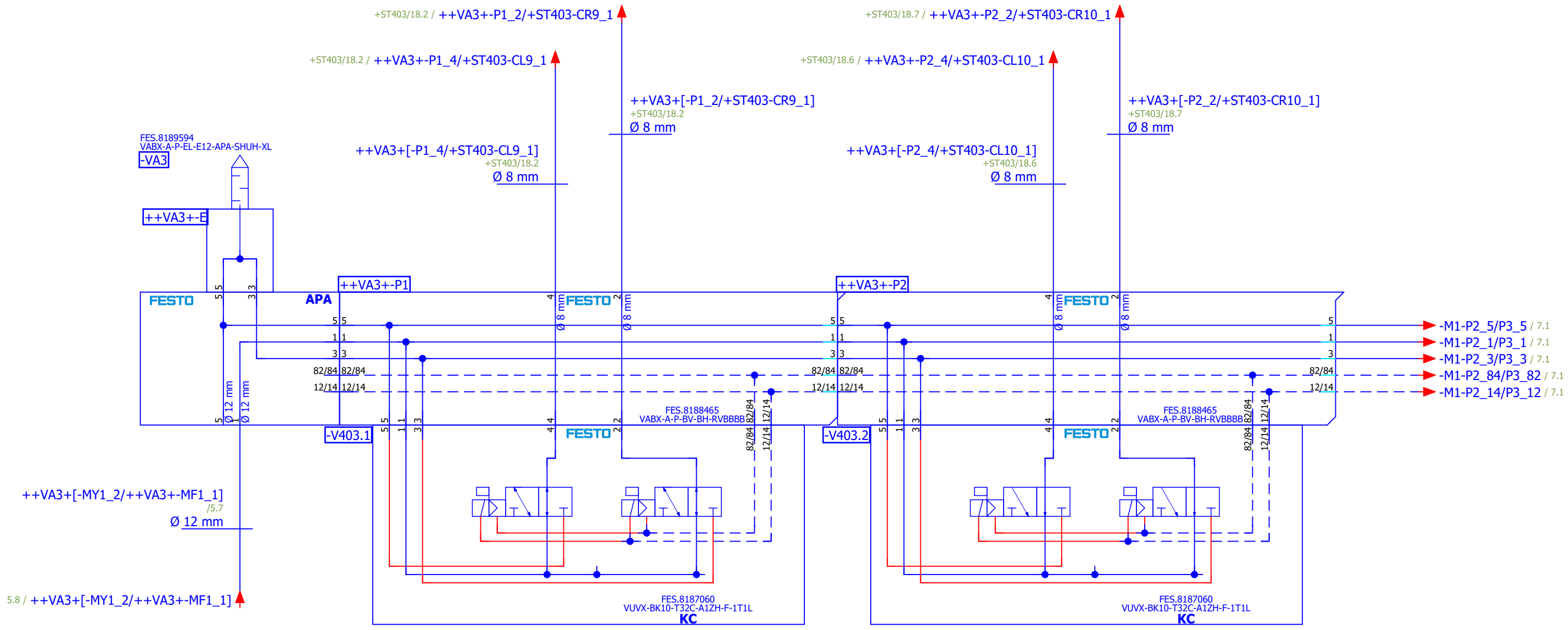

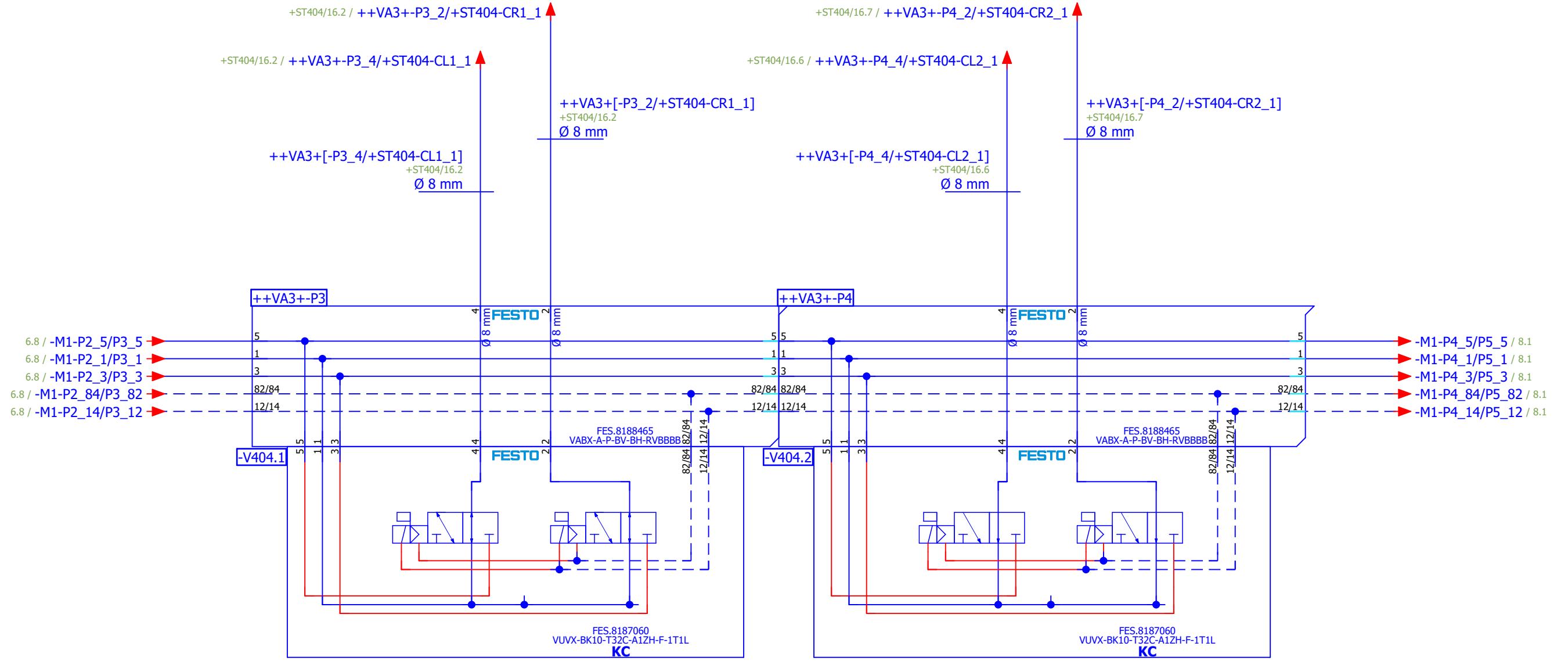

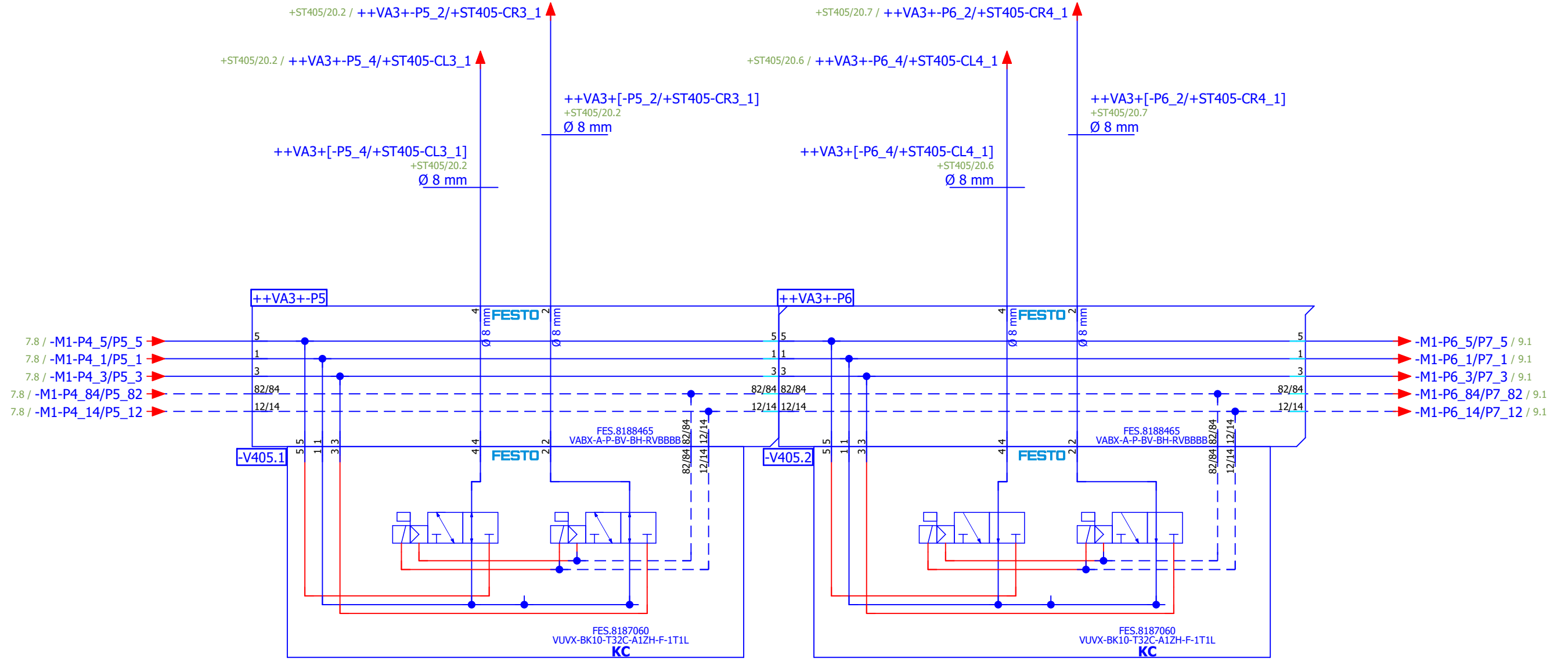

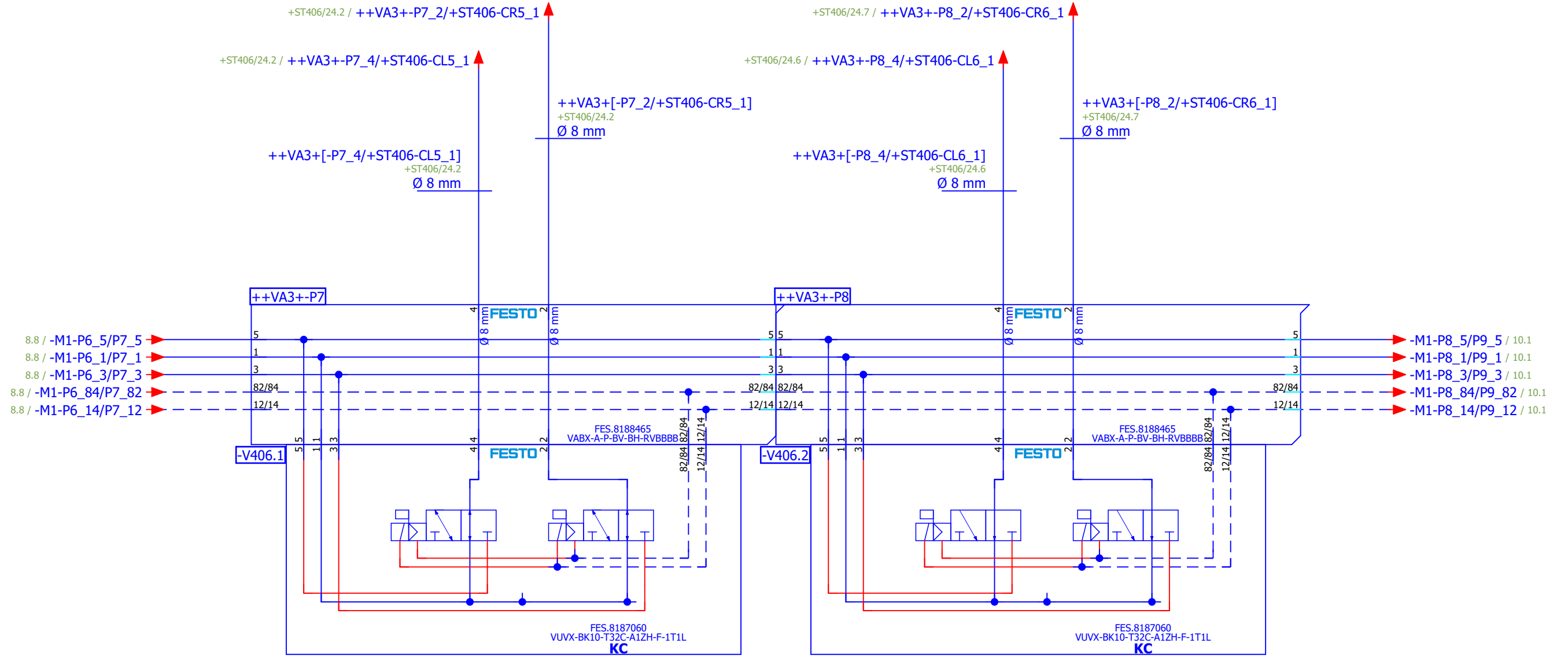

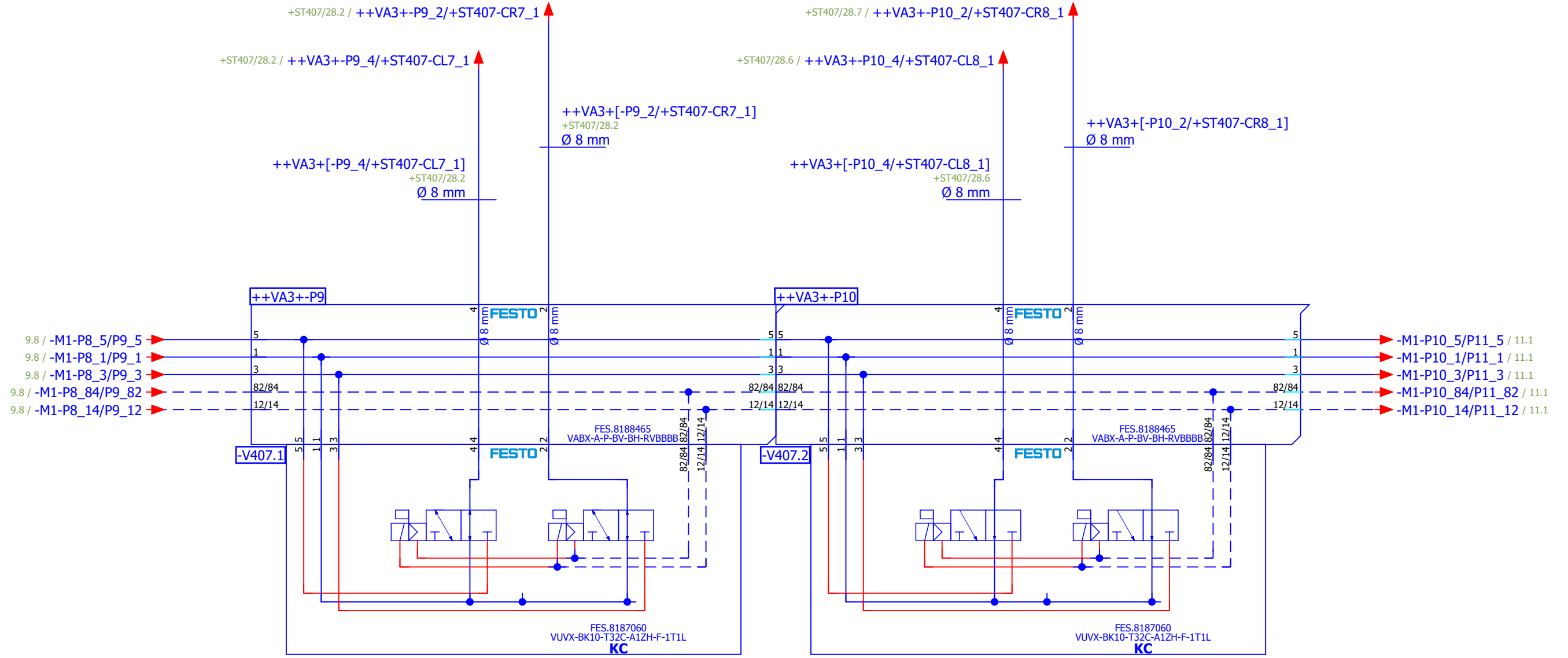

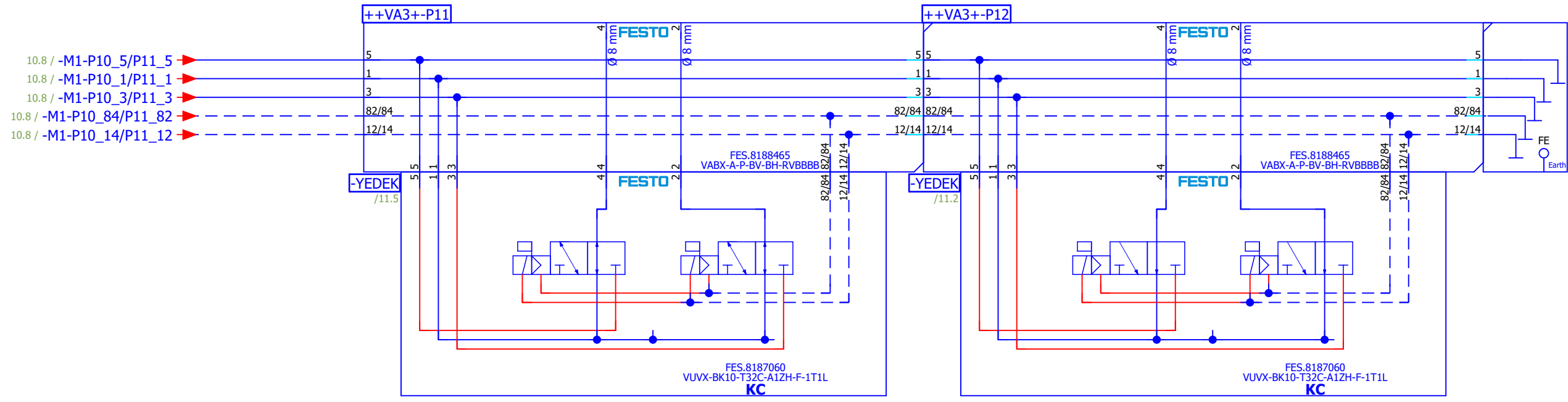



 <p>Yeşilyurt, Muhtar Cafer Sk. No:8 41190 Başiskele/Kocaeli</p> <p>info@dssotomasyon.com.tr</p> <p>+90 544 322 23 10</p>		<p><b>PROJE ADI</b></p> <p>PLC101 stoper</p>	<p><b>SAYFA AÇIKLAMASI</b></p> <p>-VA3-YEDEK</p>	<p>Çizen: Hasancan Simen</p> <p>Kontrol Eden: Sabri Ebrem</p>	<p>Sayfa 11</p> <p>T. Sayfa 108 / 167</p>
		<p><b>++VA3</b></p>	<p><b>+</b></p>		

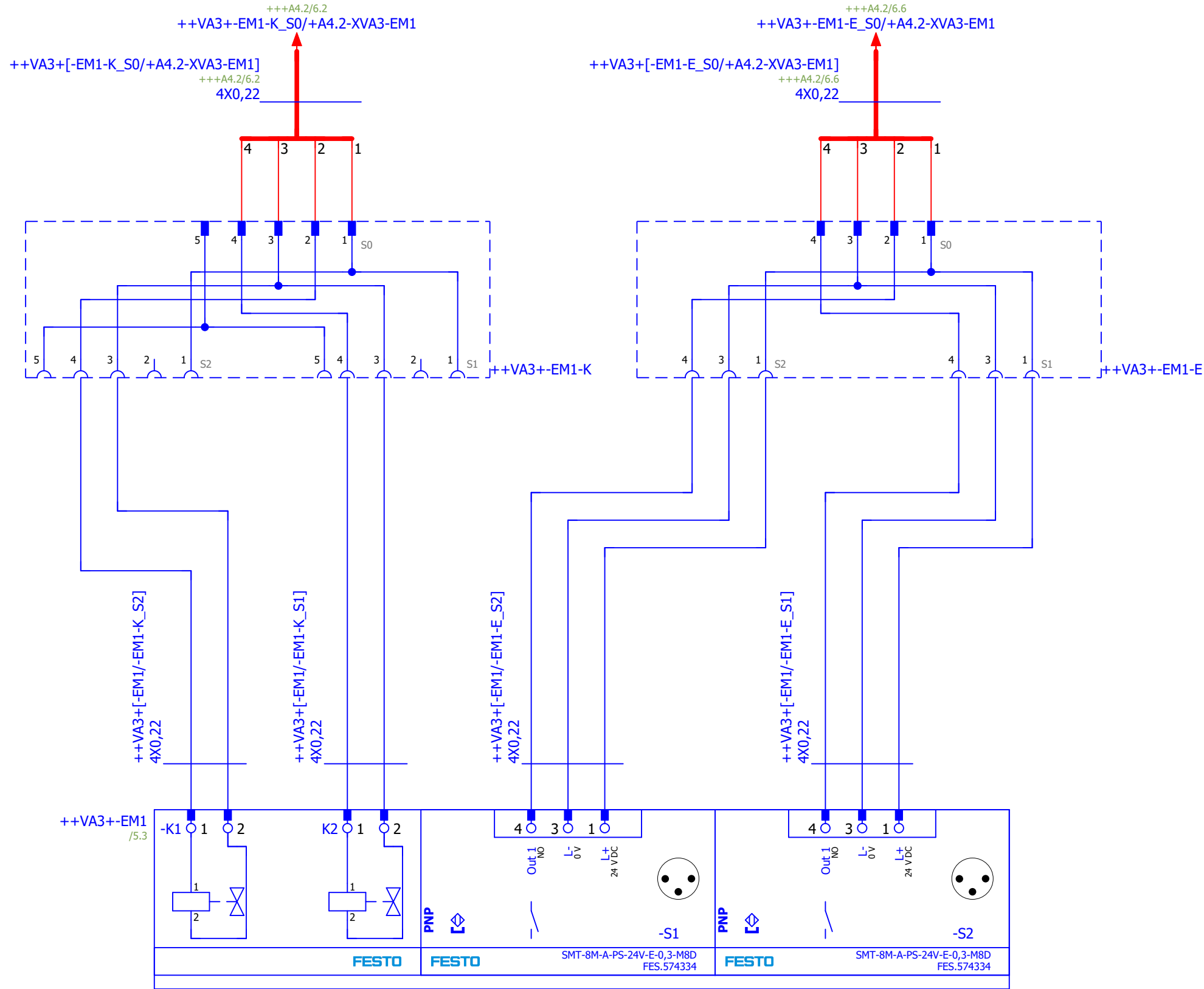
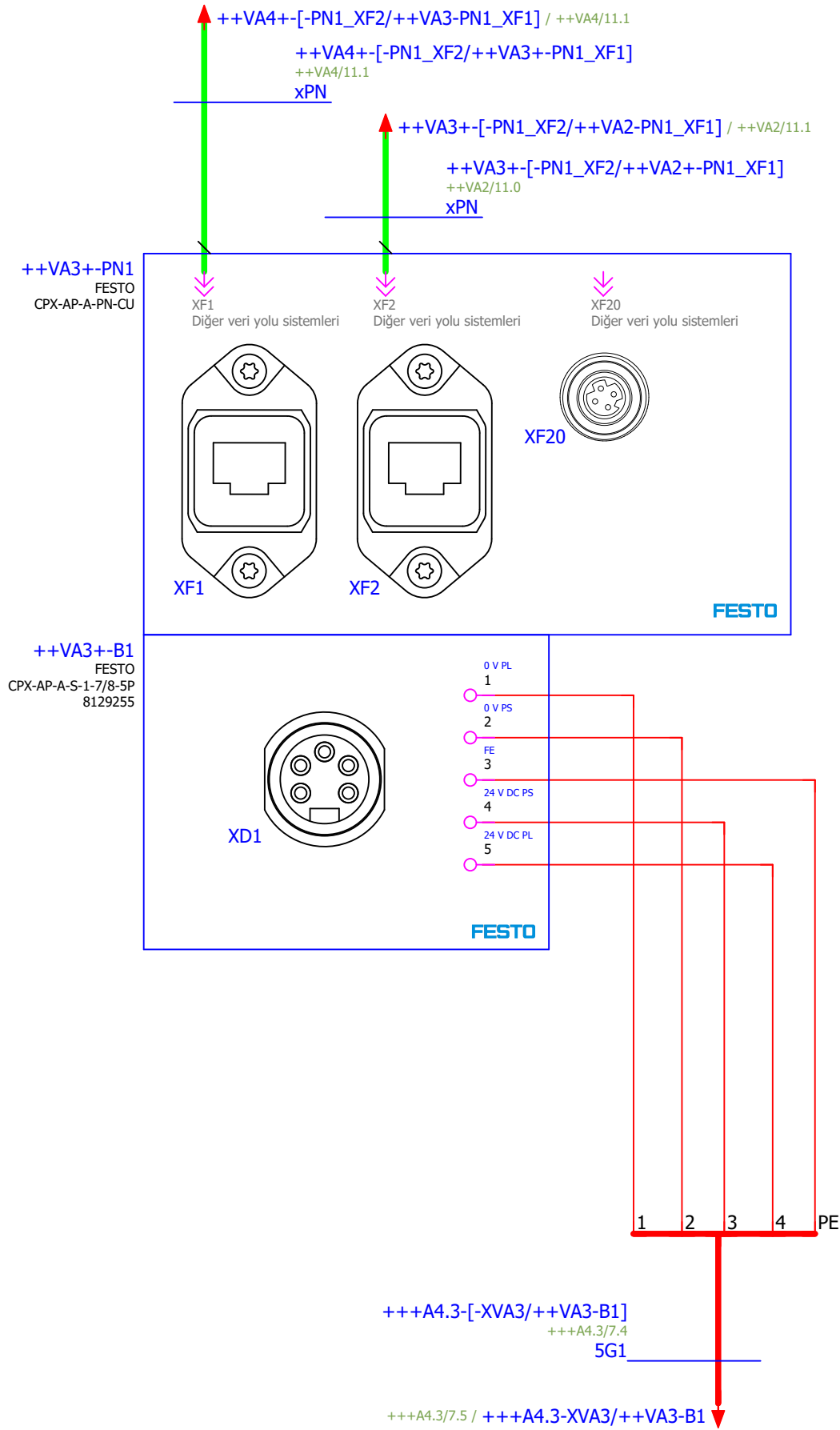

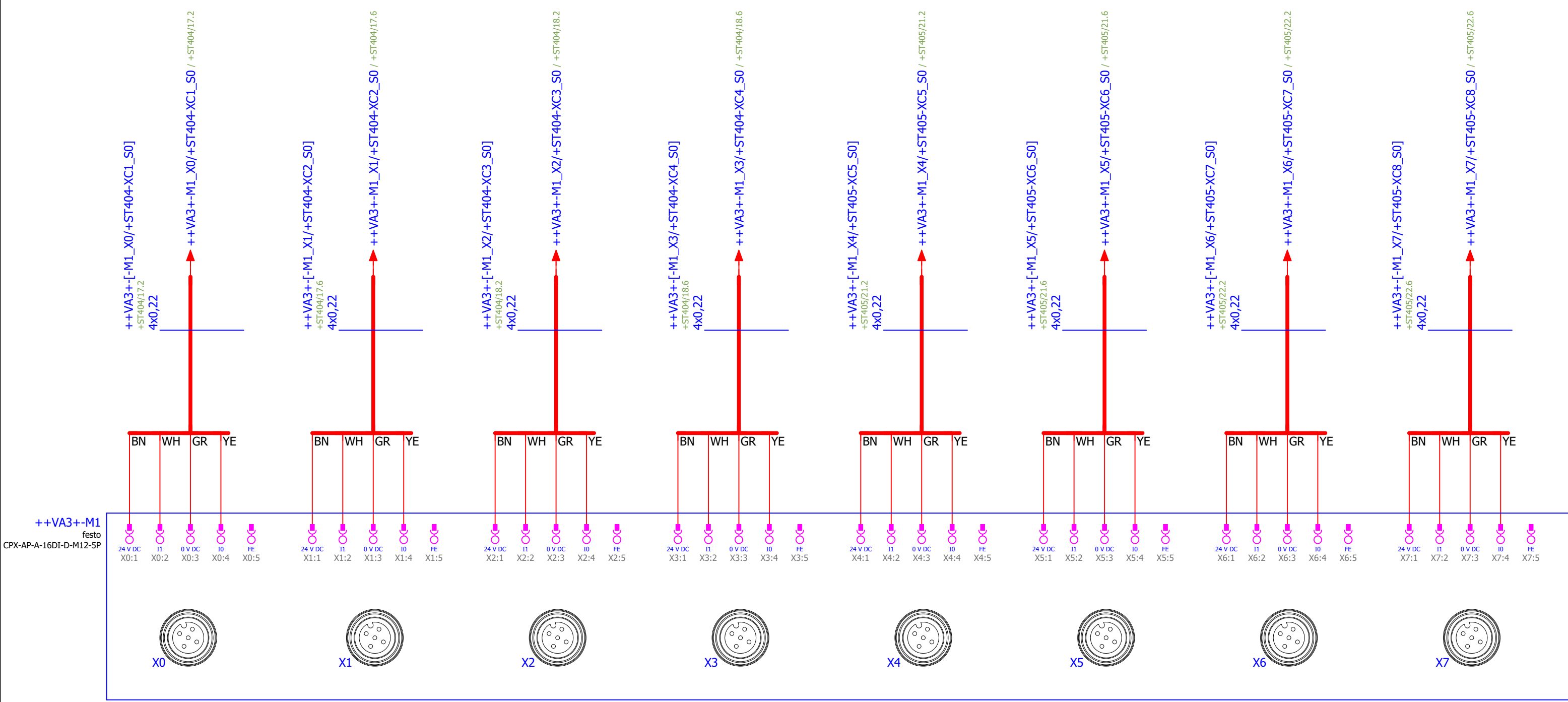

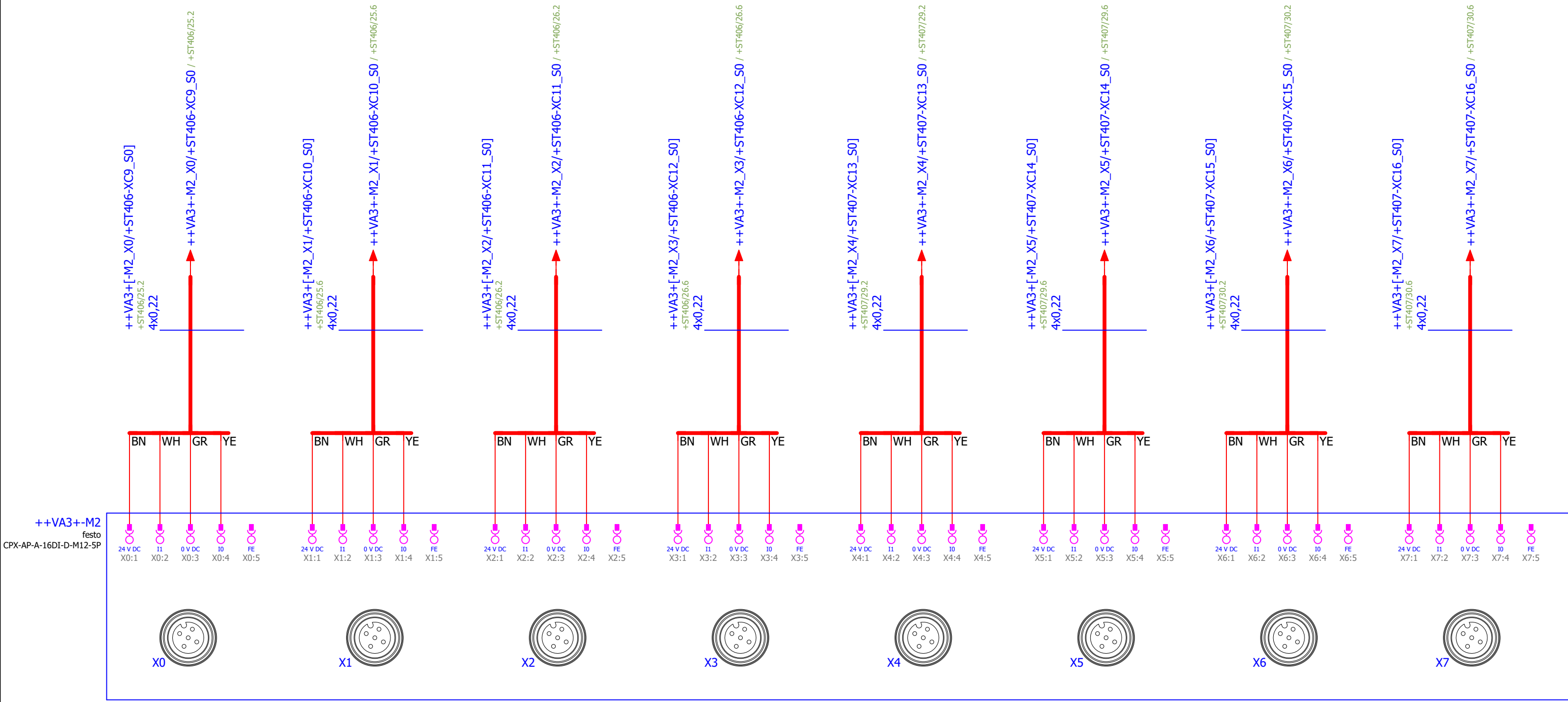

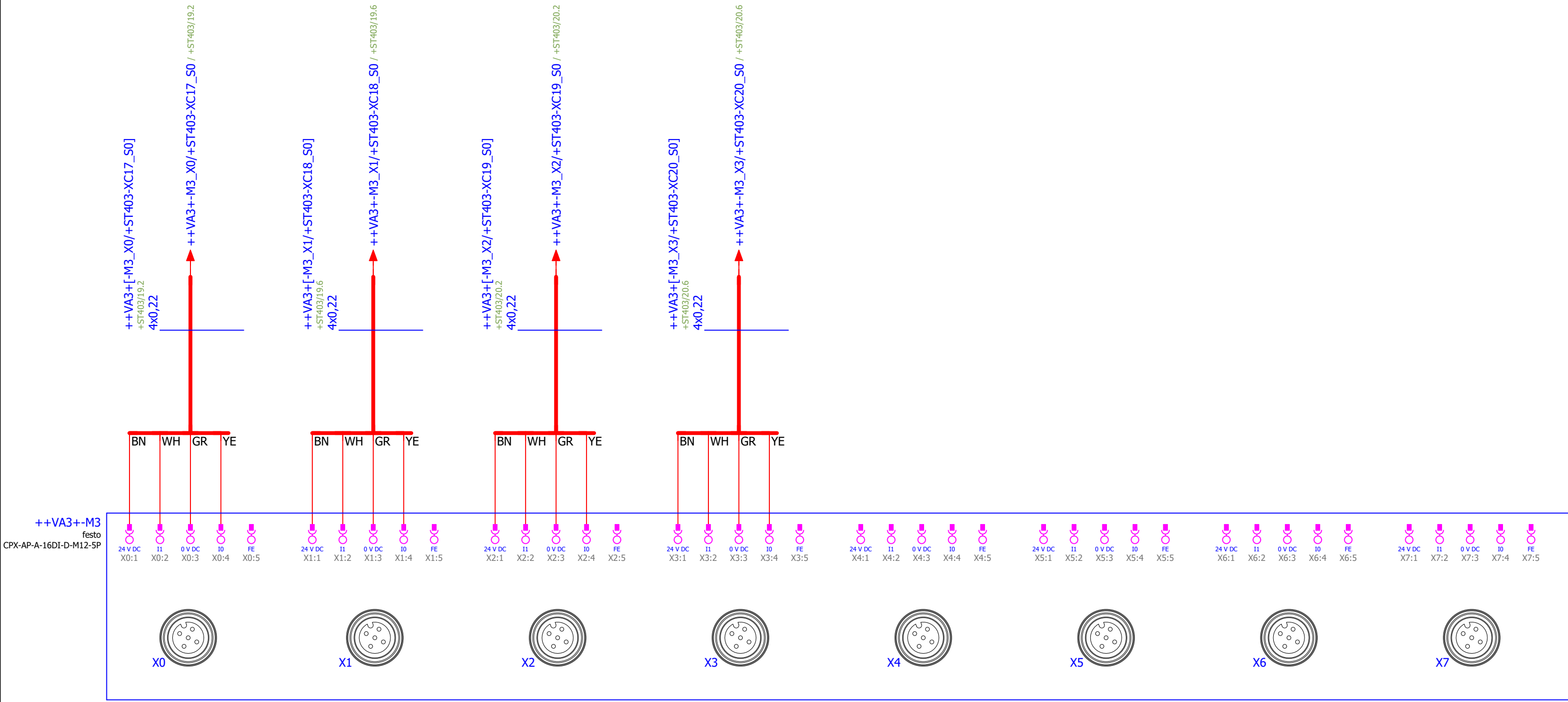

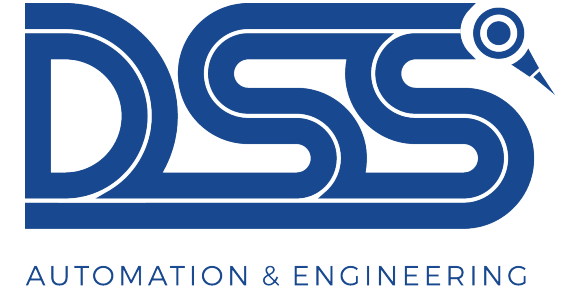

Müşteri : FORD OTOSAN

Üretici (şirket) : DSS OTOMASYON

+ST403



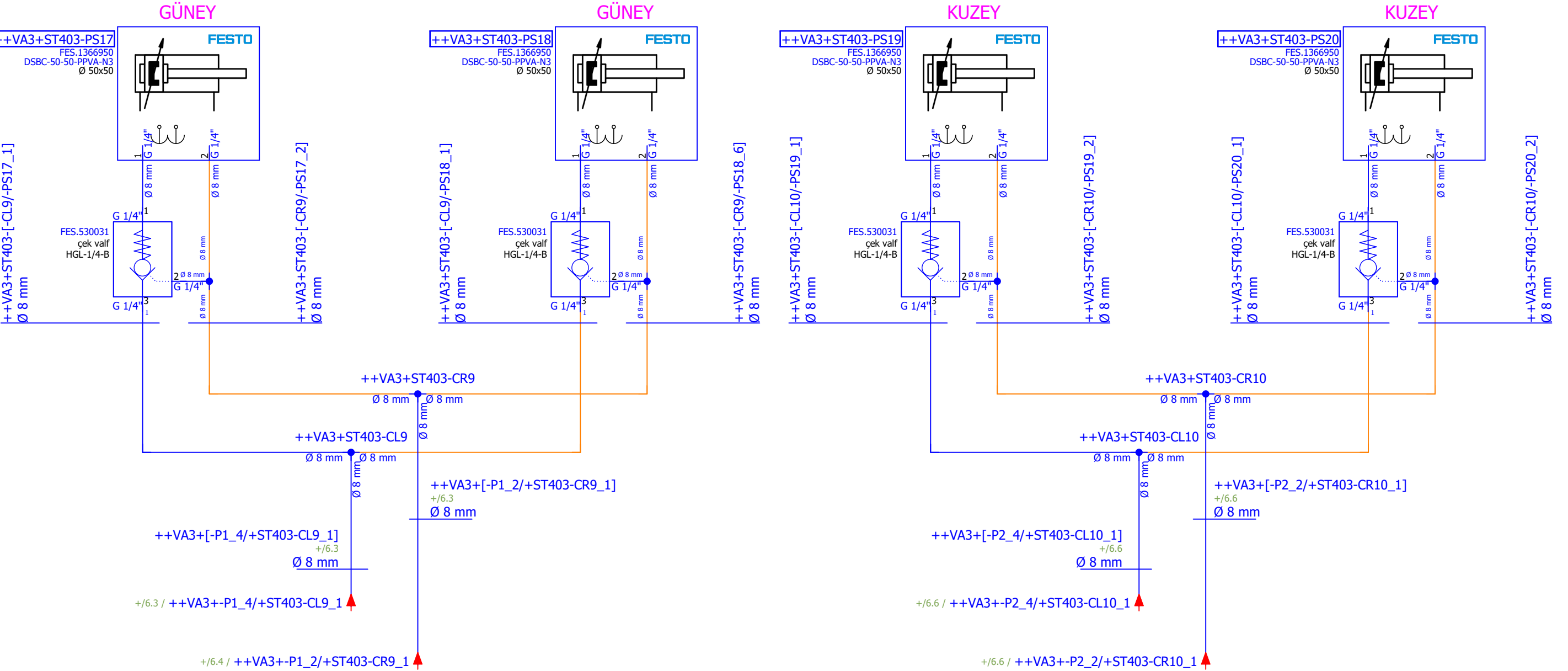

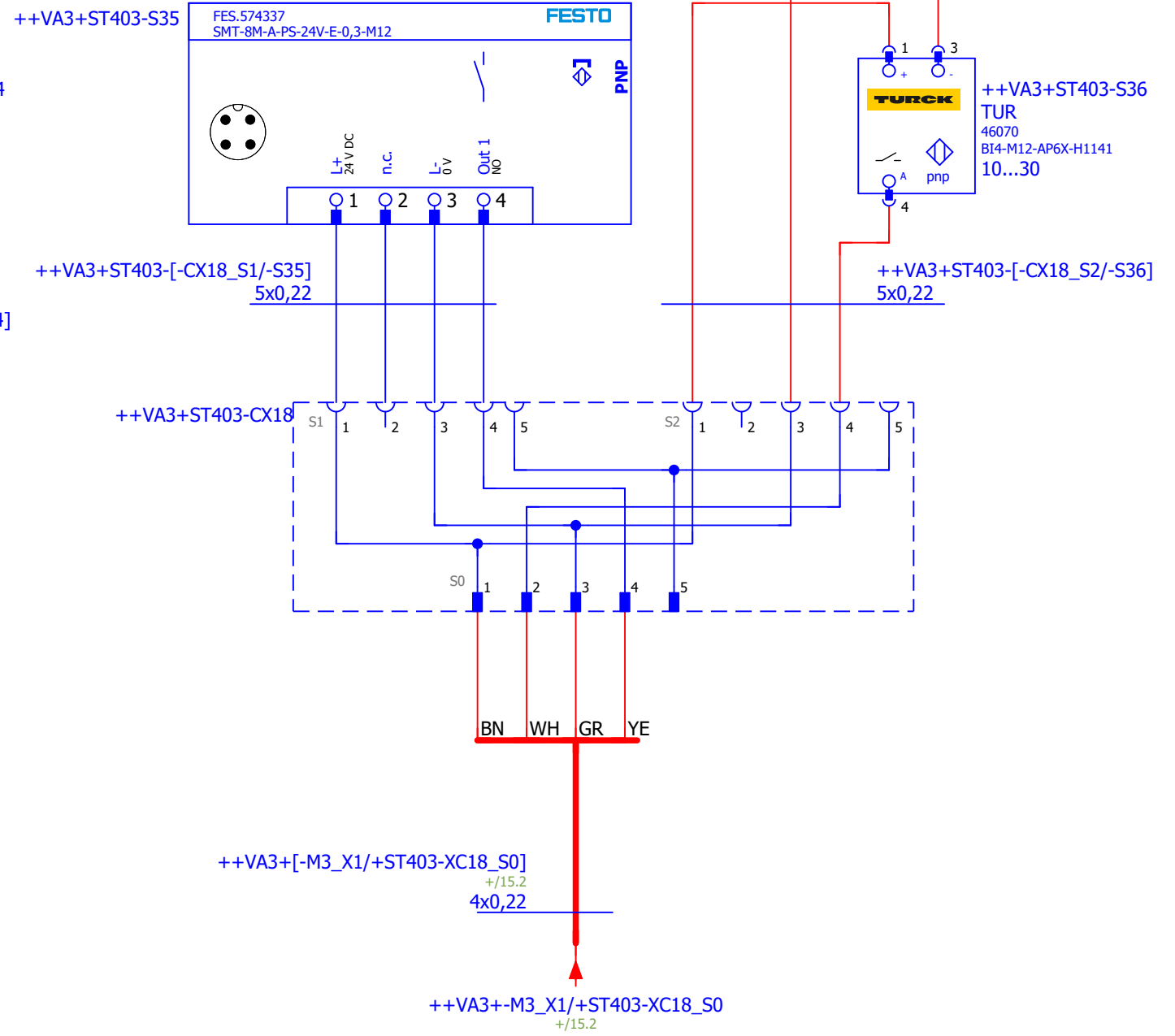
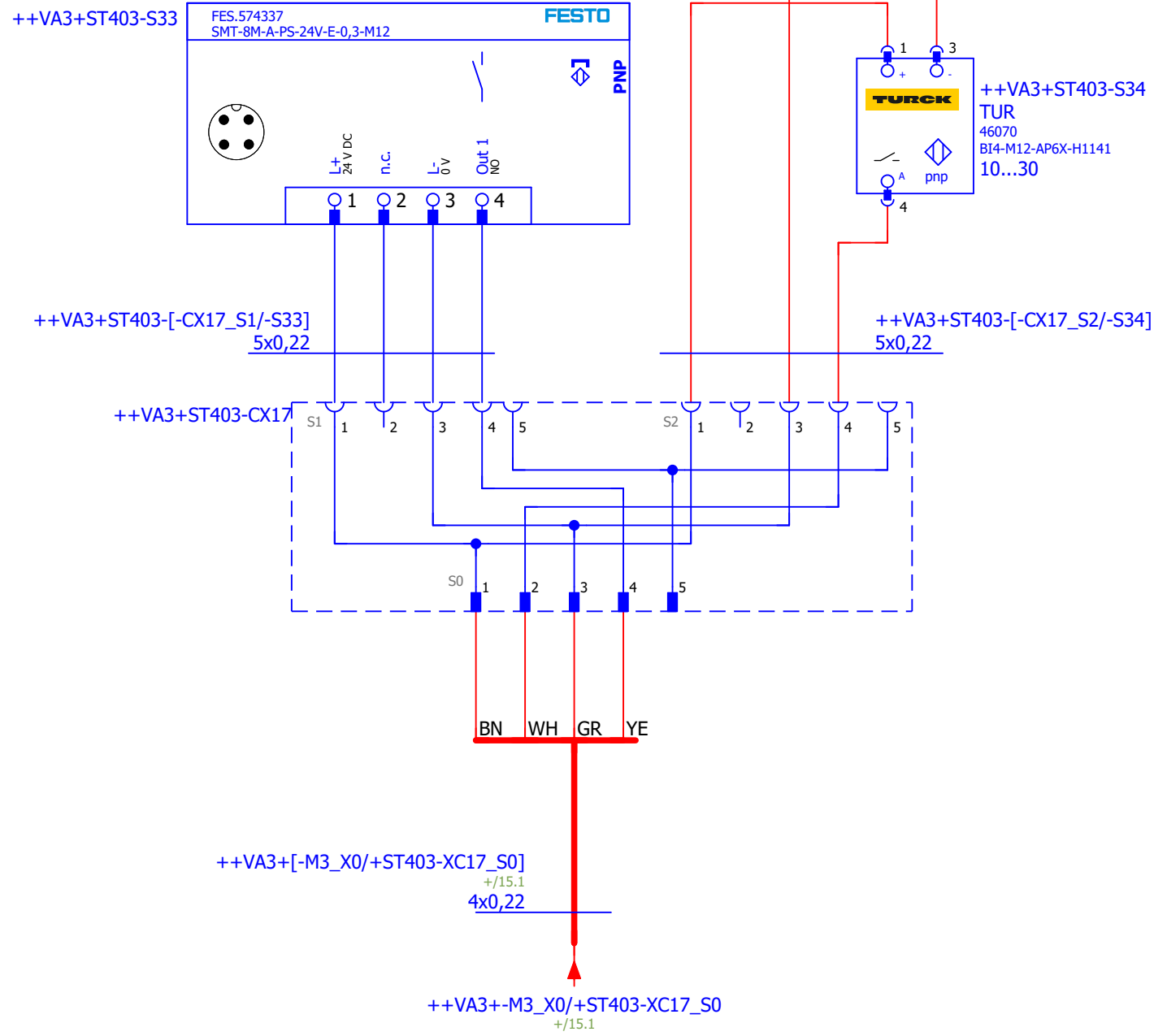

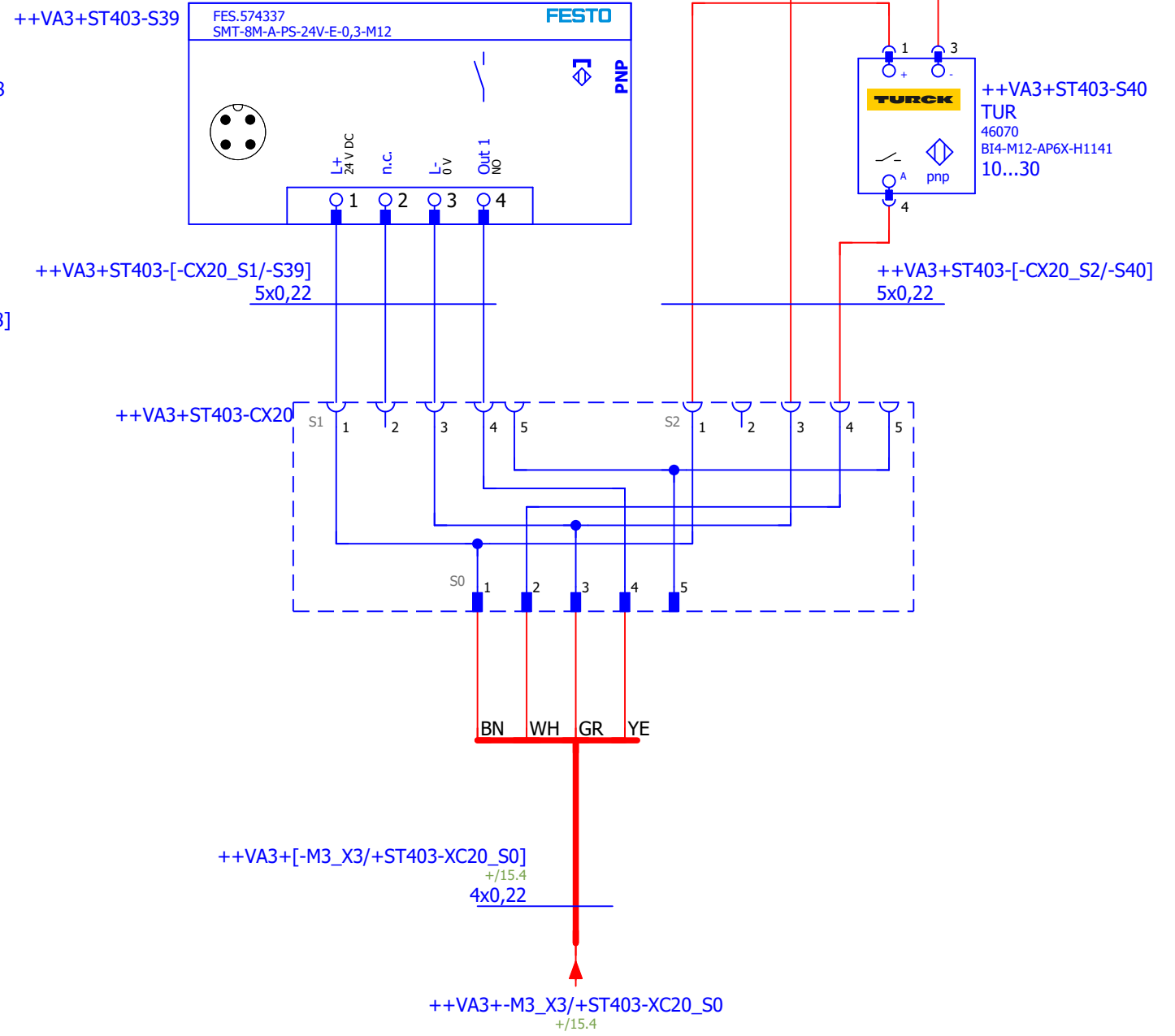
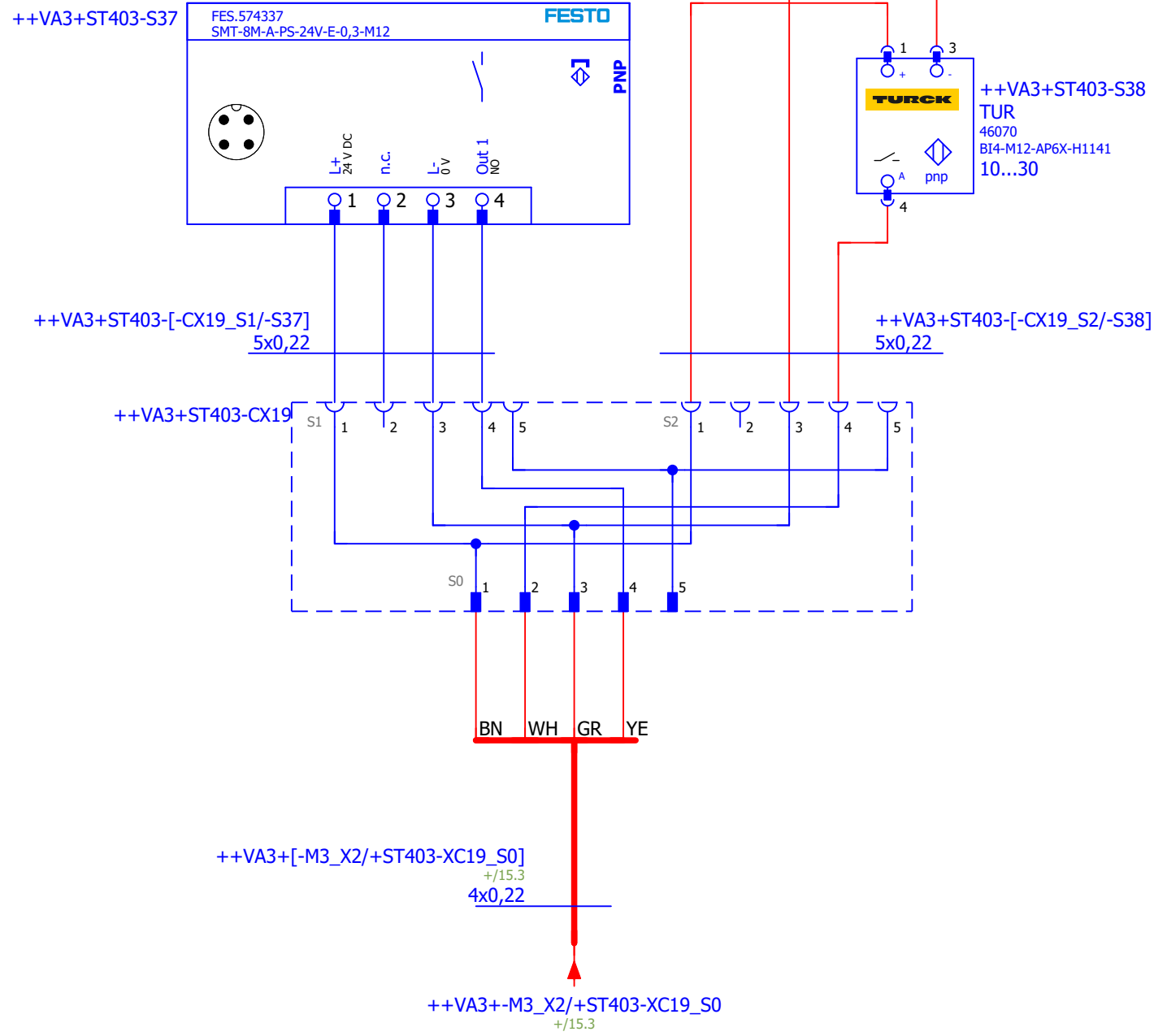

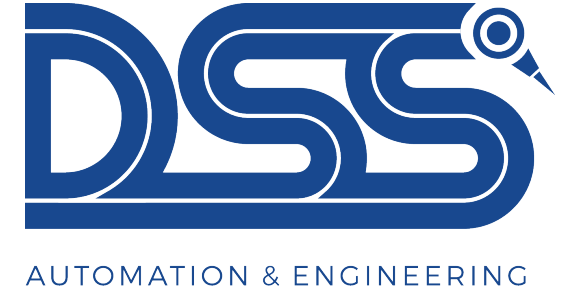

Müşteri : FORD OTOSAN

Üretici (şirket) : DSS OTOMASYON

+ST404



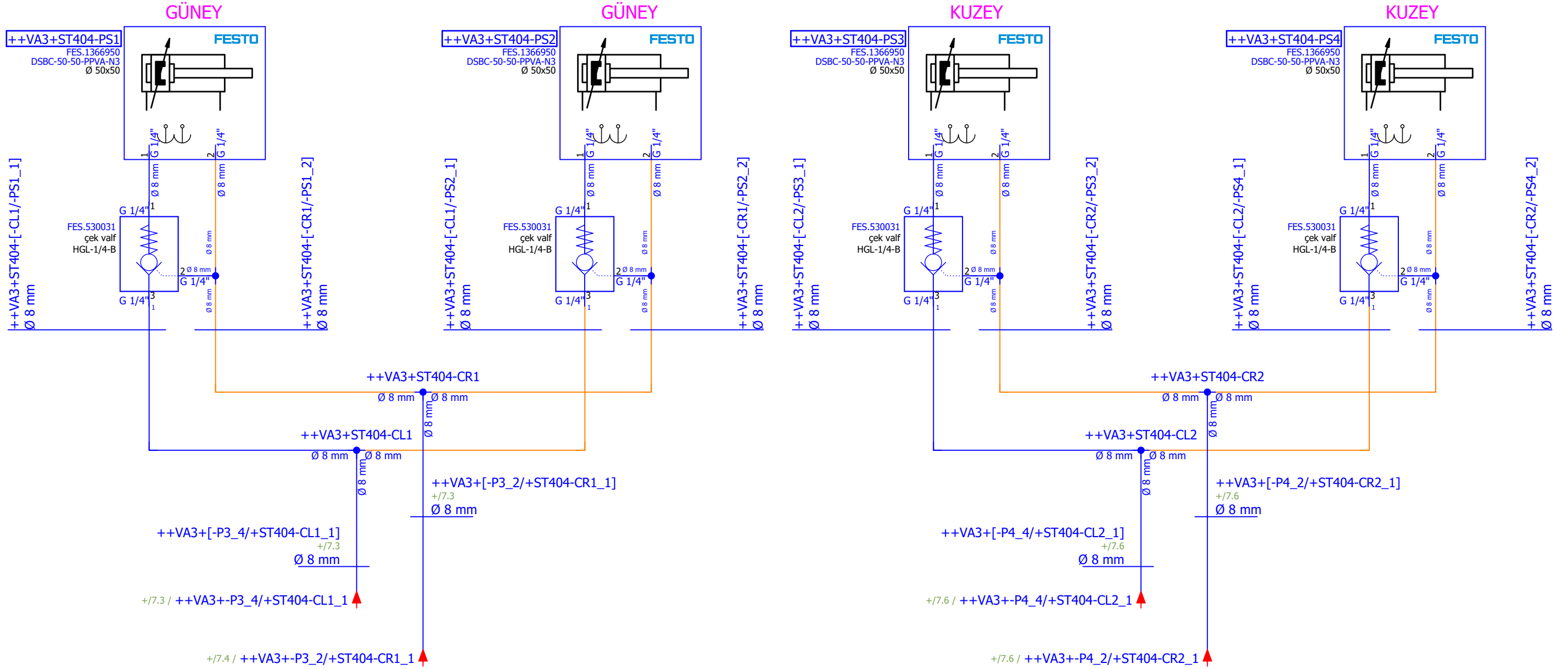

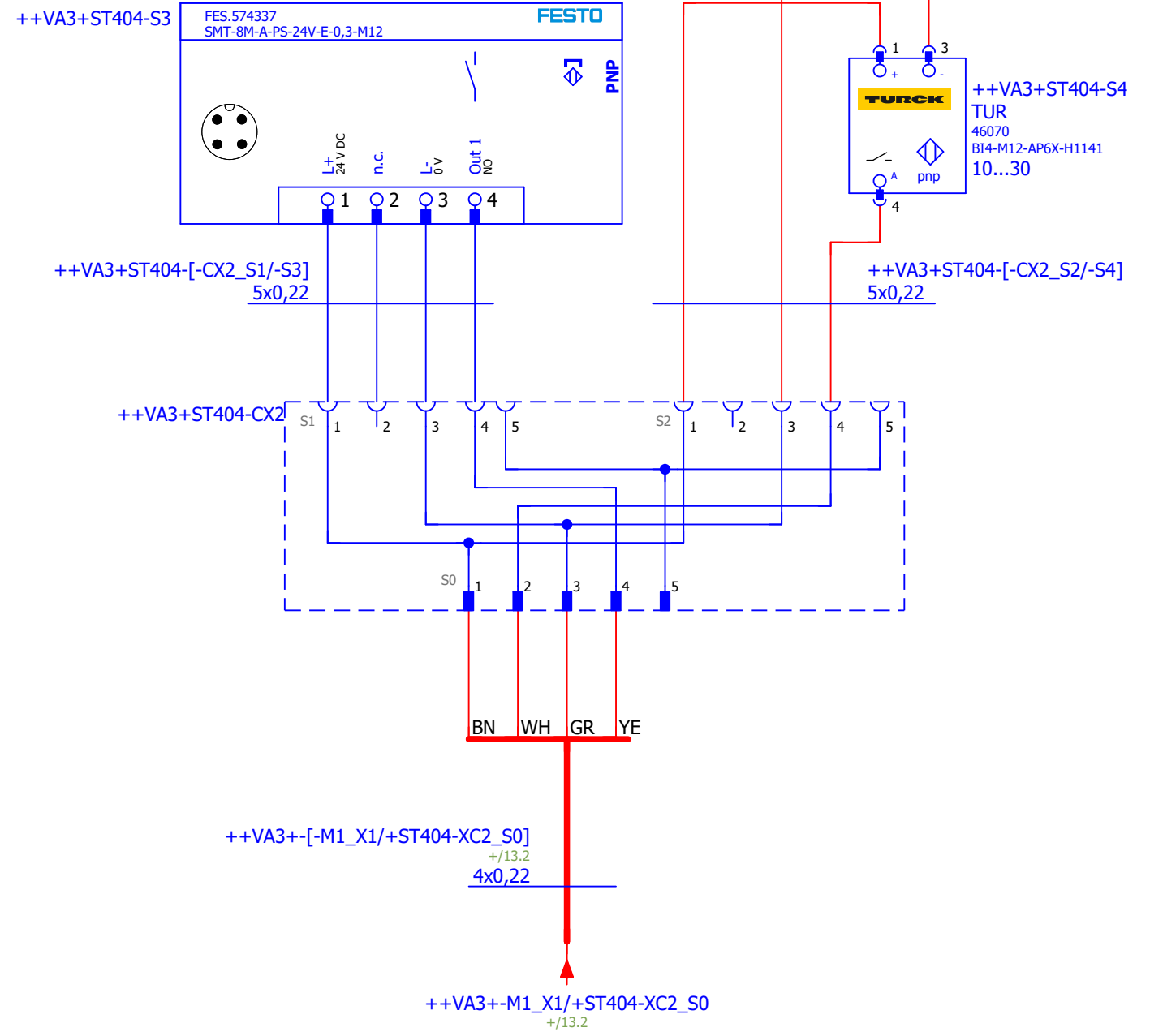
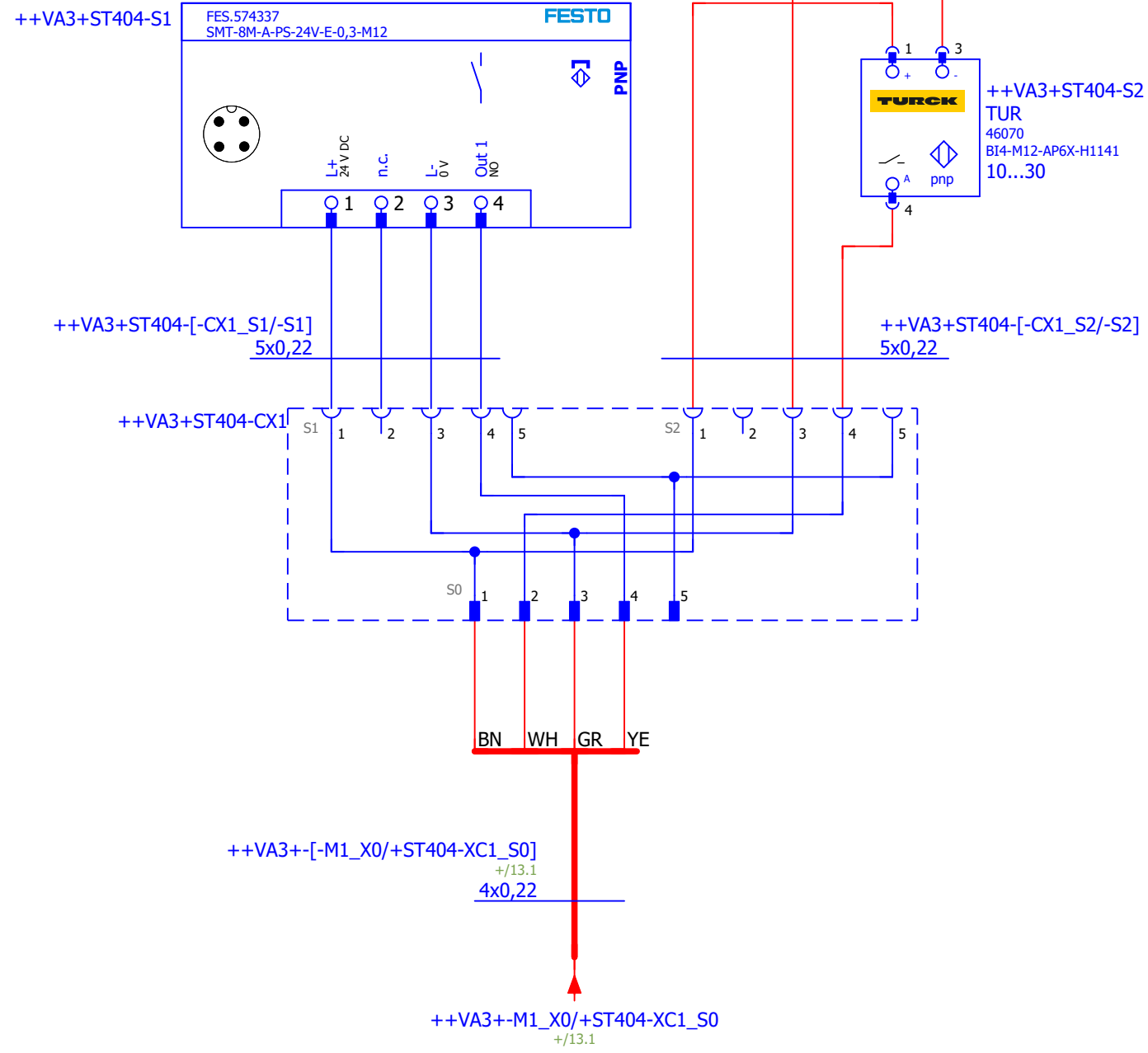

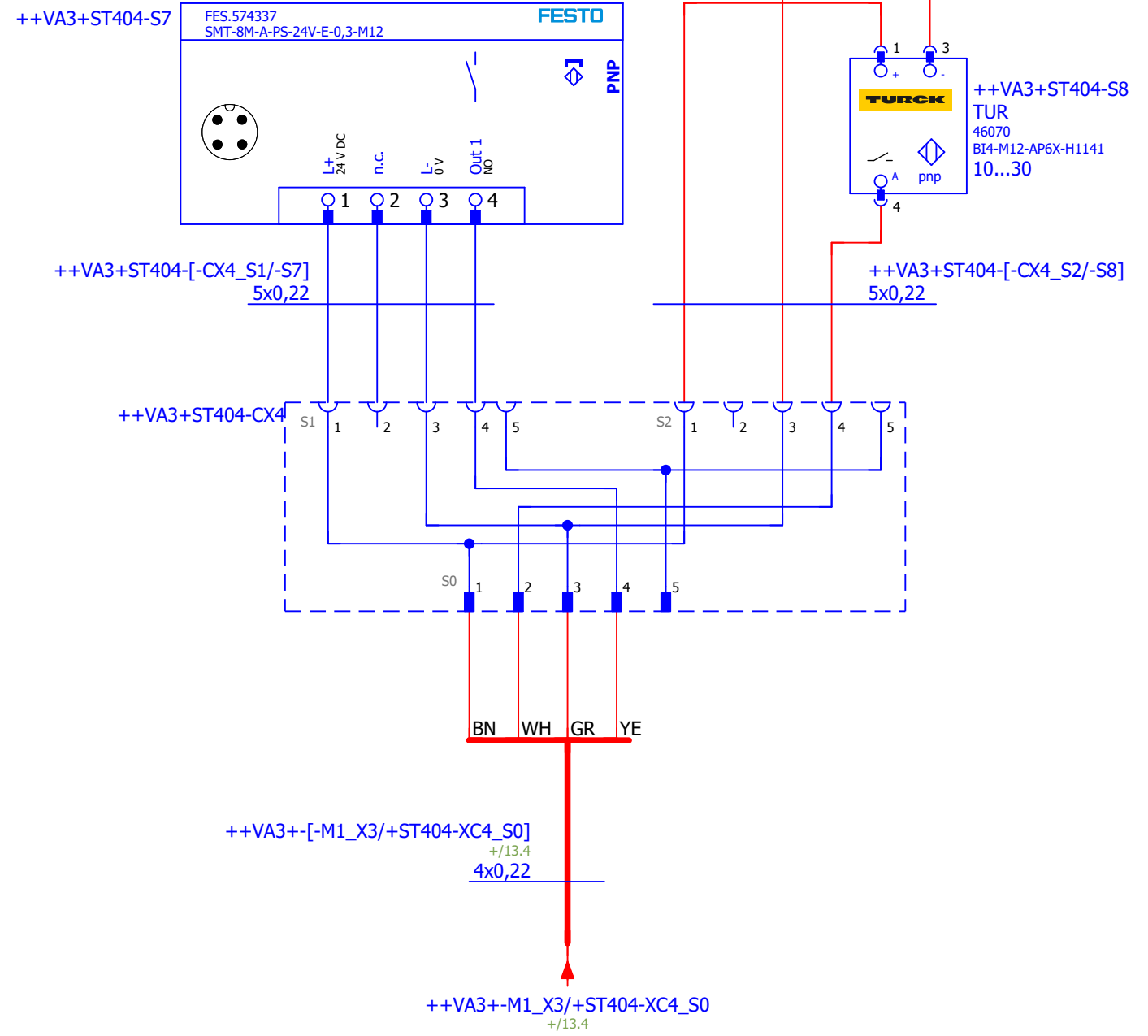
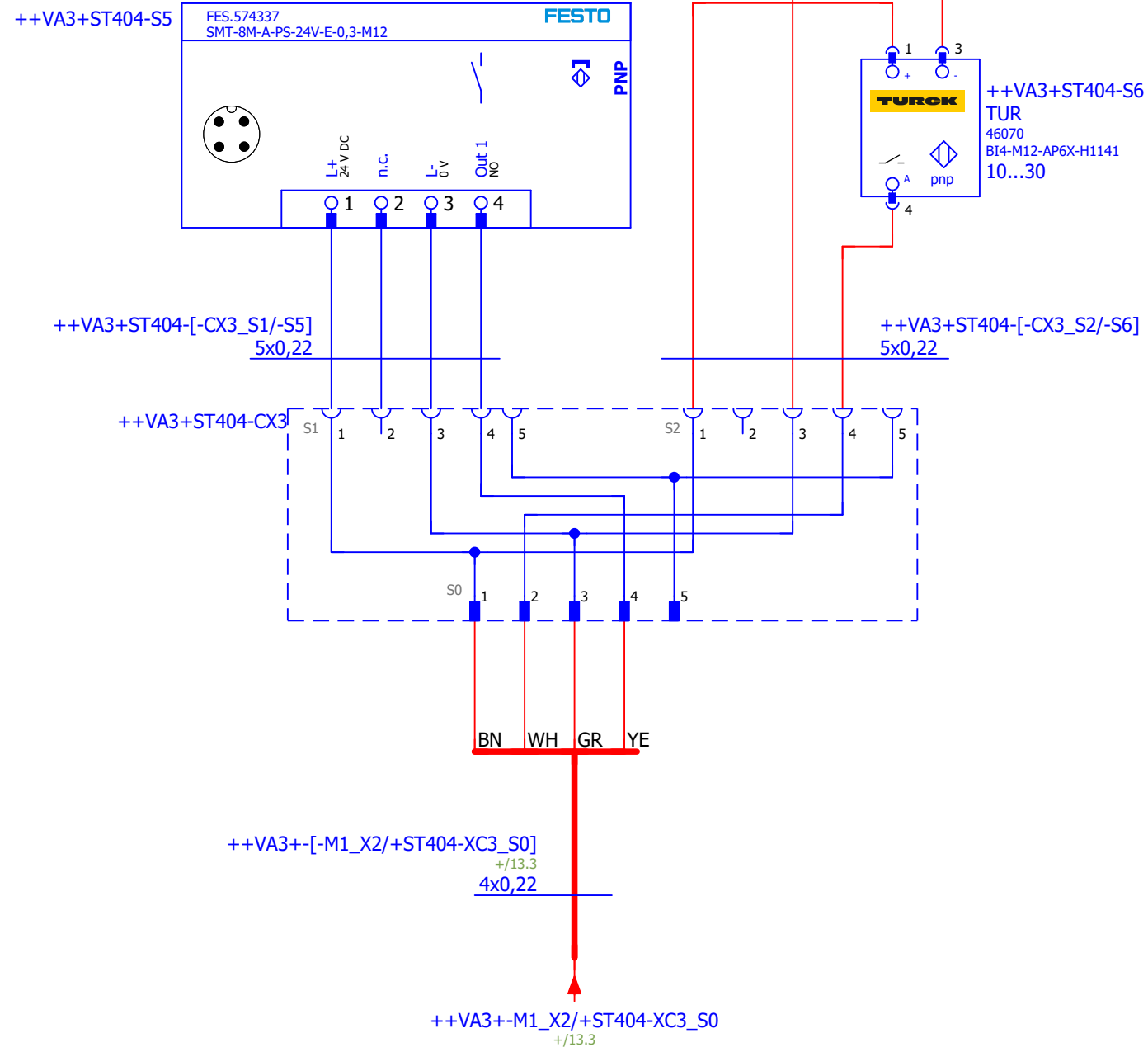

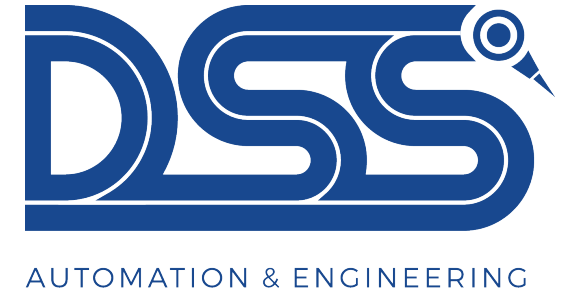

Müşteri : FORD OTOSAN

Üretici (şirket) : DSS OTOMASYON

+ST405



	Yeşilyurt, Muhtar Cafer Sk. No:8 41190 Başiskele/Kocaeli		<b>PROJE ADI</b>	<b>SAYFA AÇIKLAMASI</b>	Çizen: Hasancan Simen	Sayfa 19
	info@dssotomasyon.com.tr		PLC101 stoper	KAPAK	Kontrol Eden: Sabri Ebrem	++VA3
	+90 544 322 23 10					+ST405

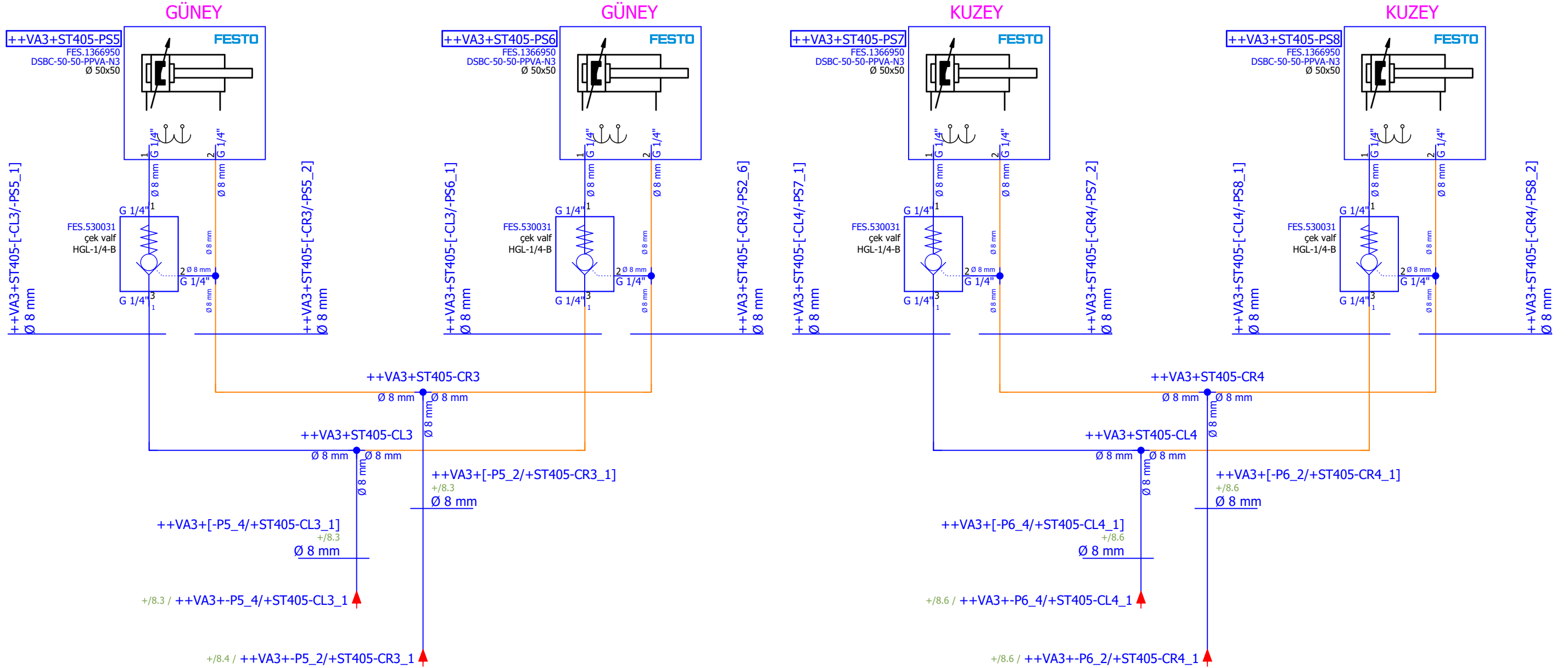

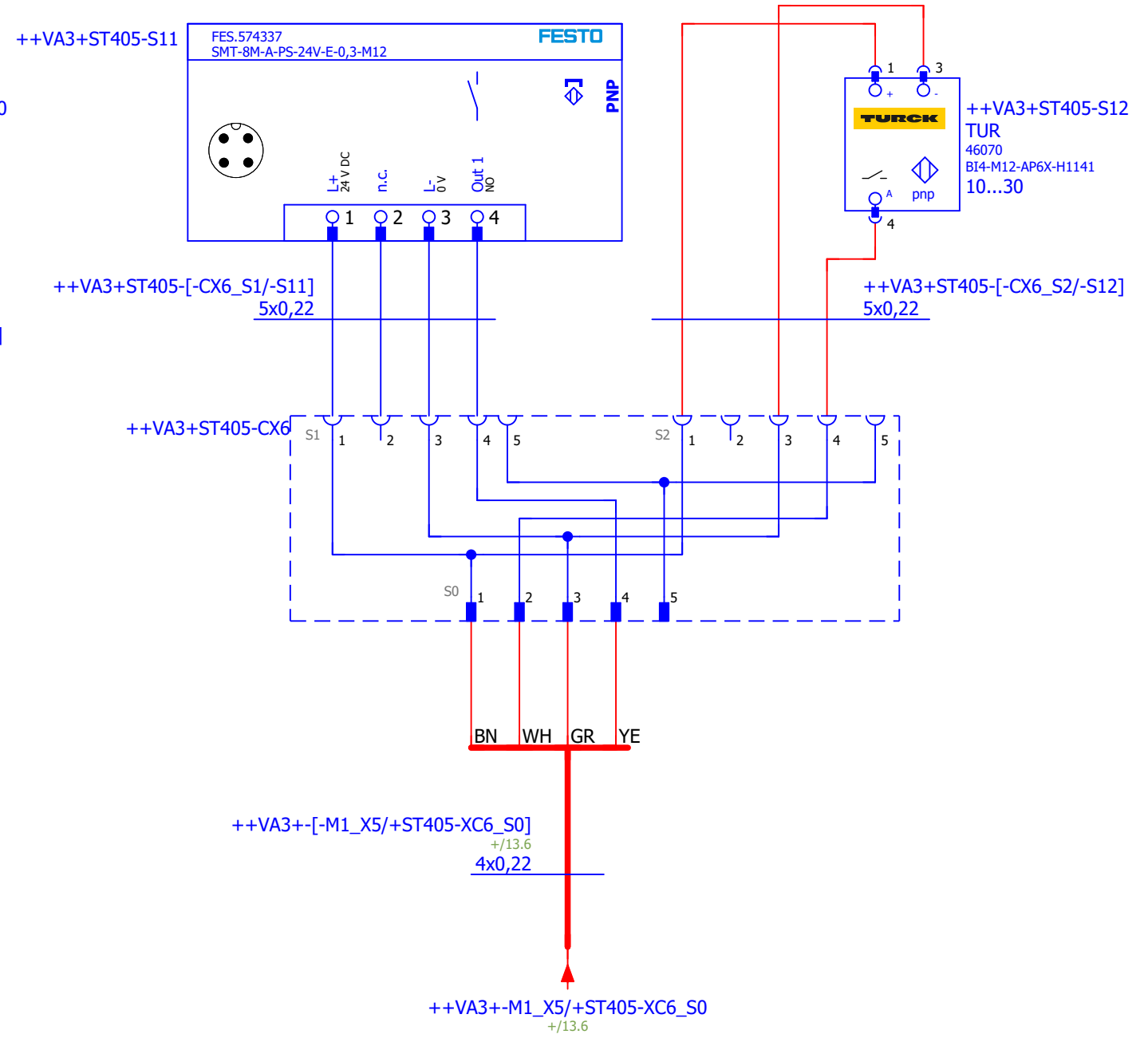
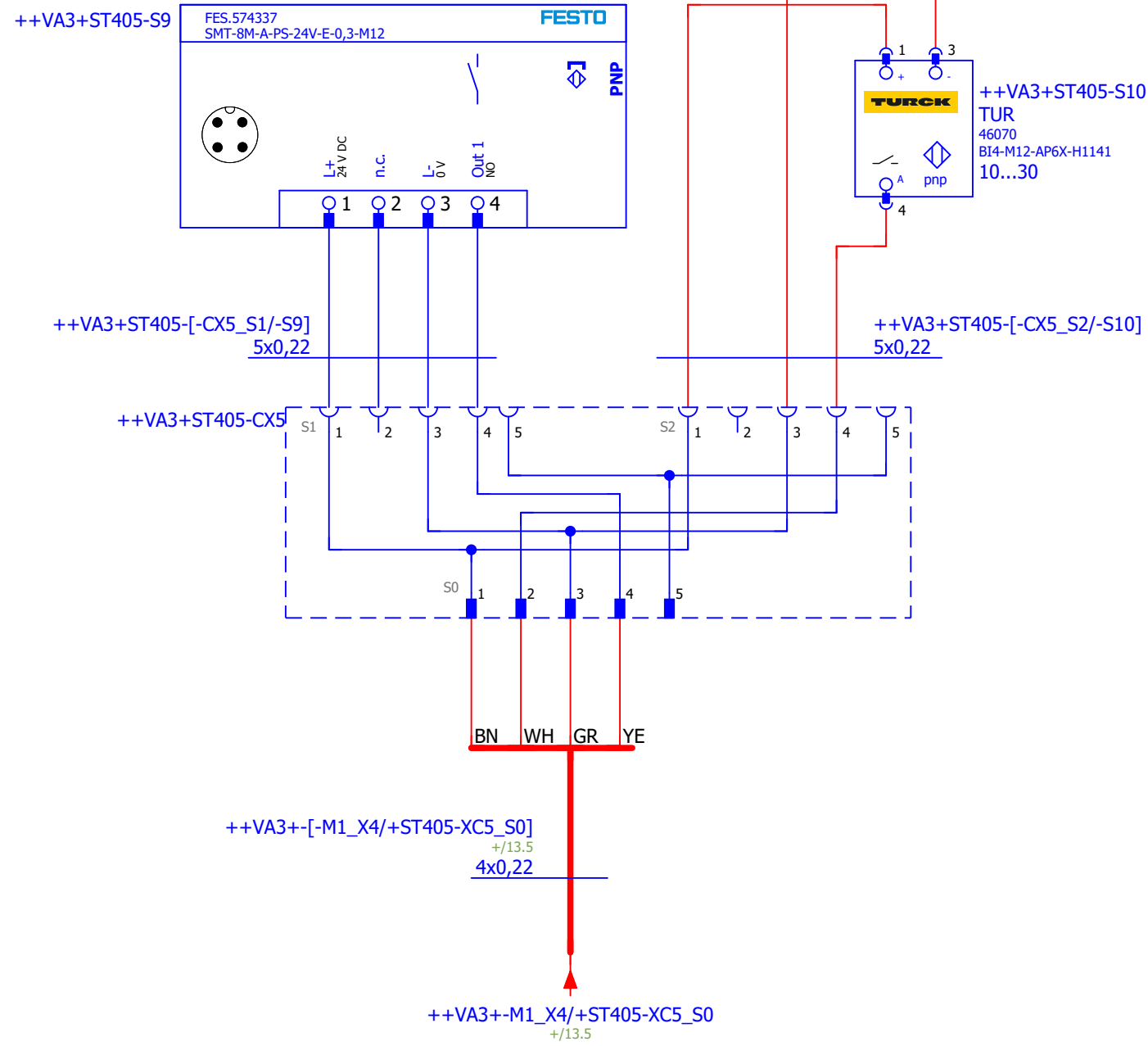

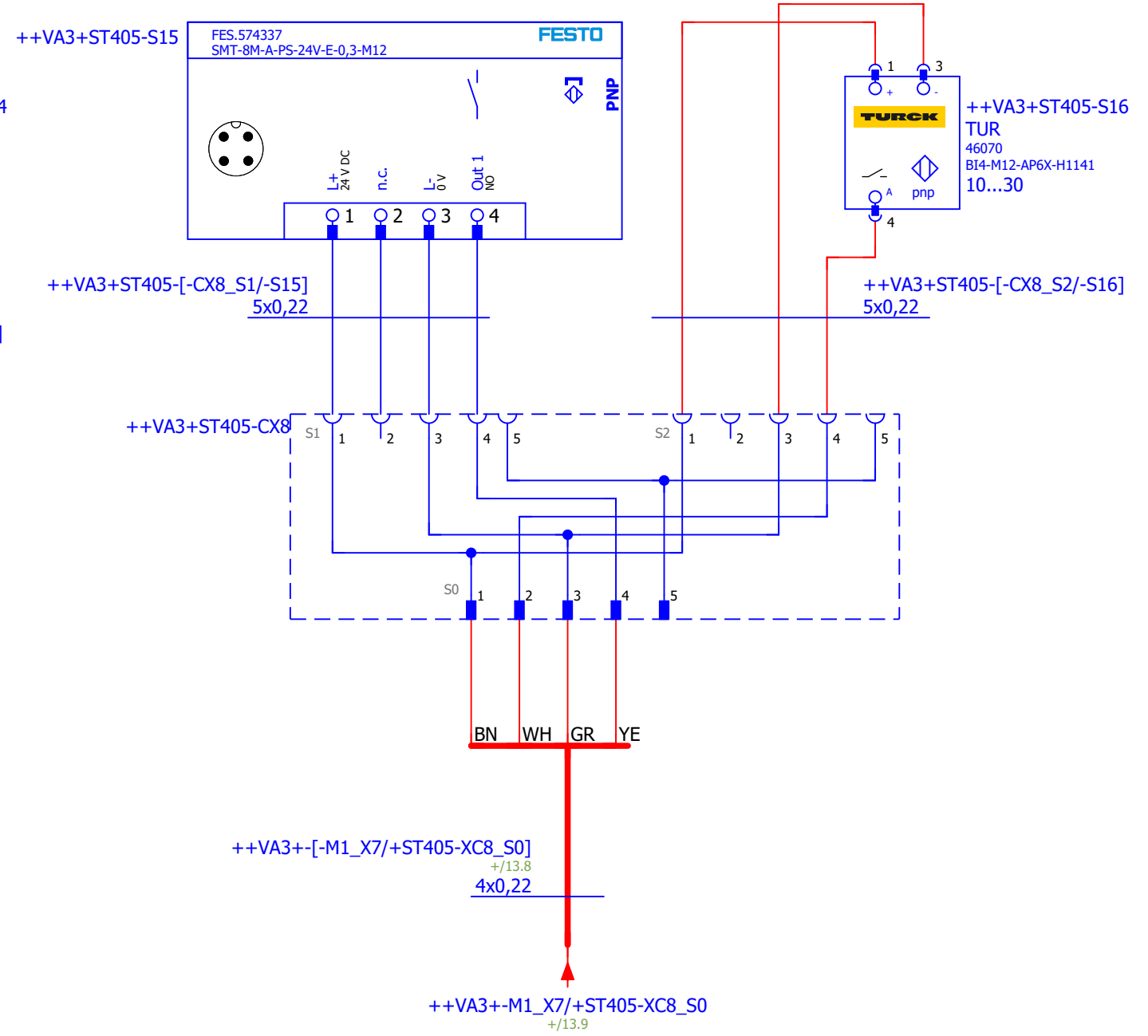
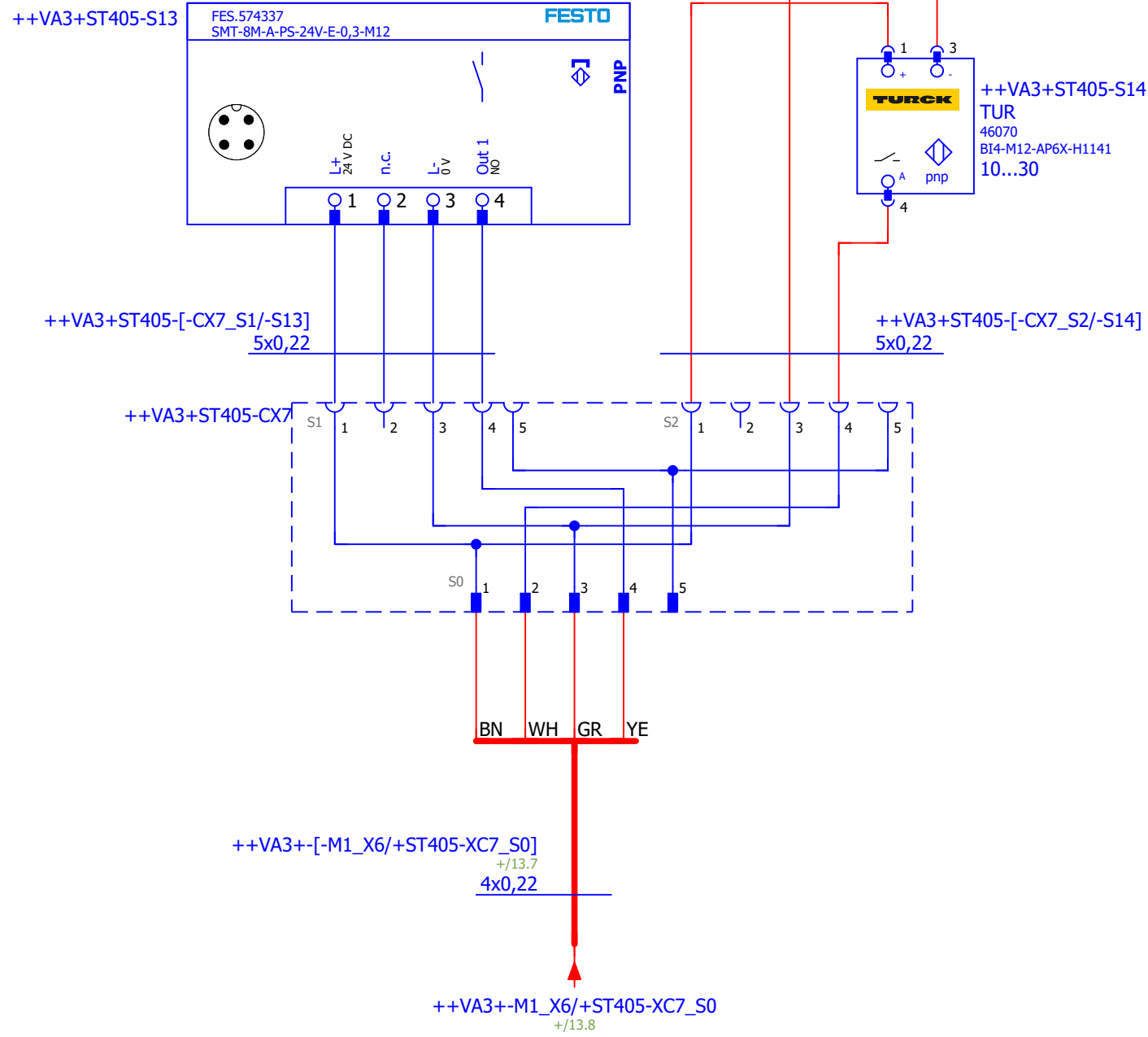

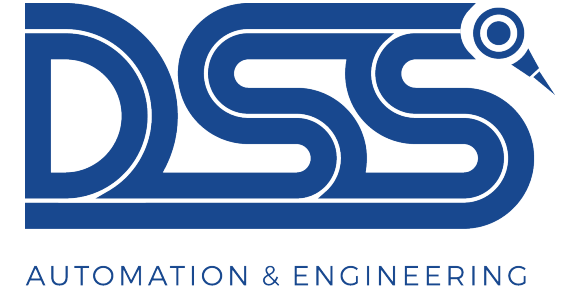

Müşteri : FORD OTOSAN

Üretici (şirket) : DSS OTOMASYON

+ST406



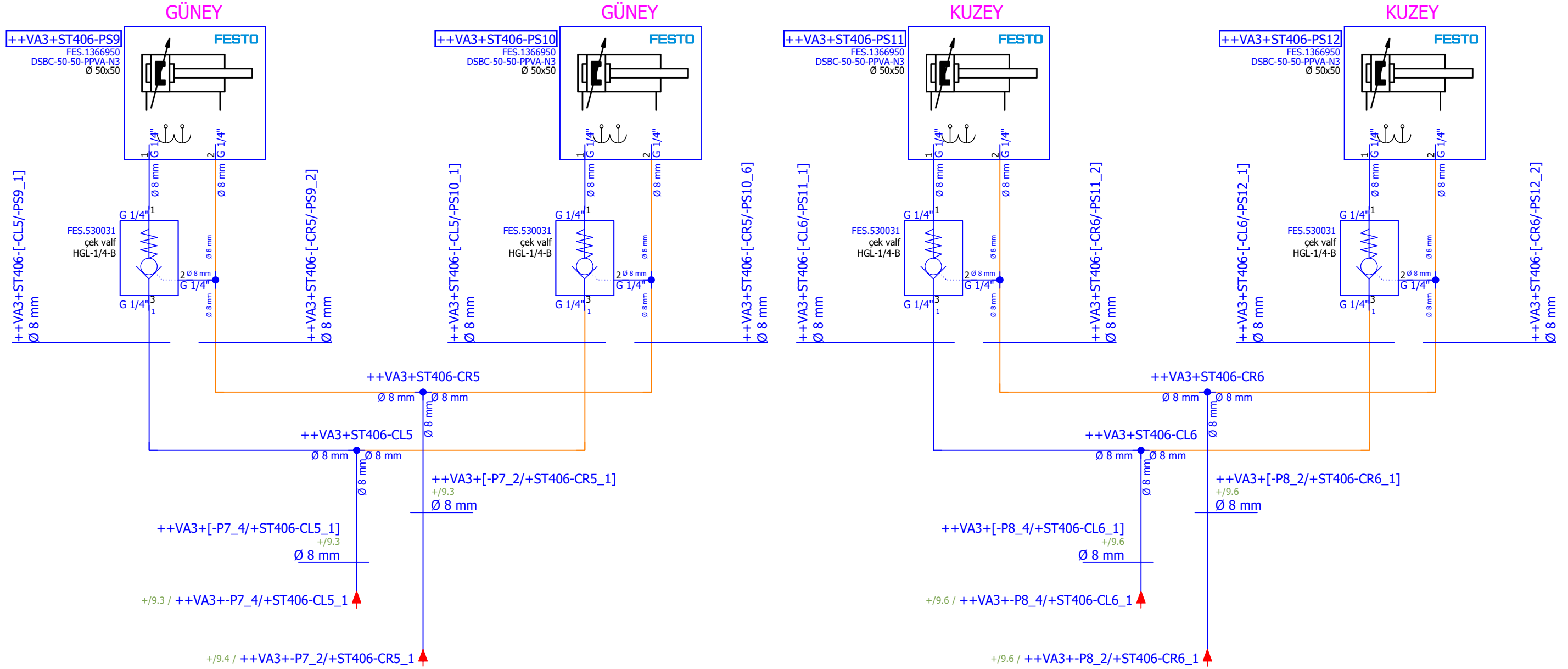

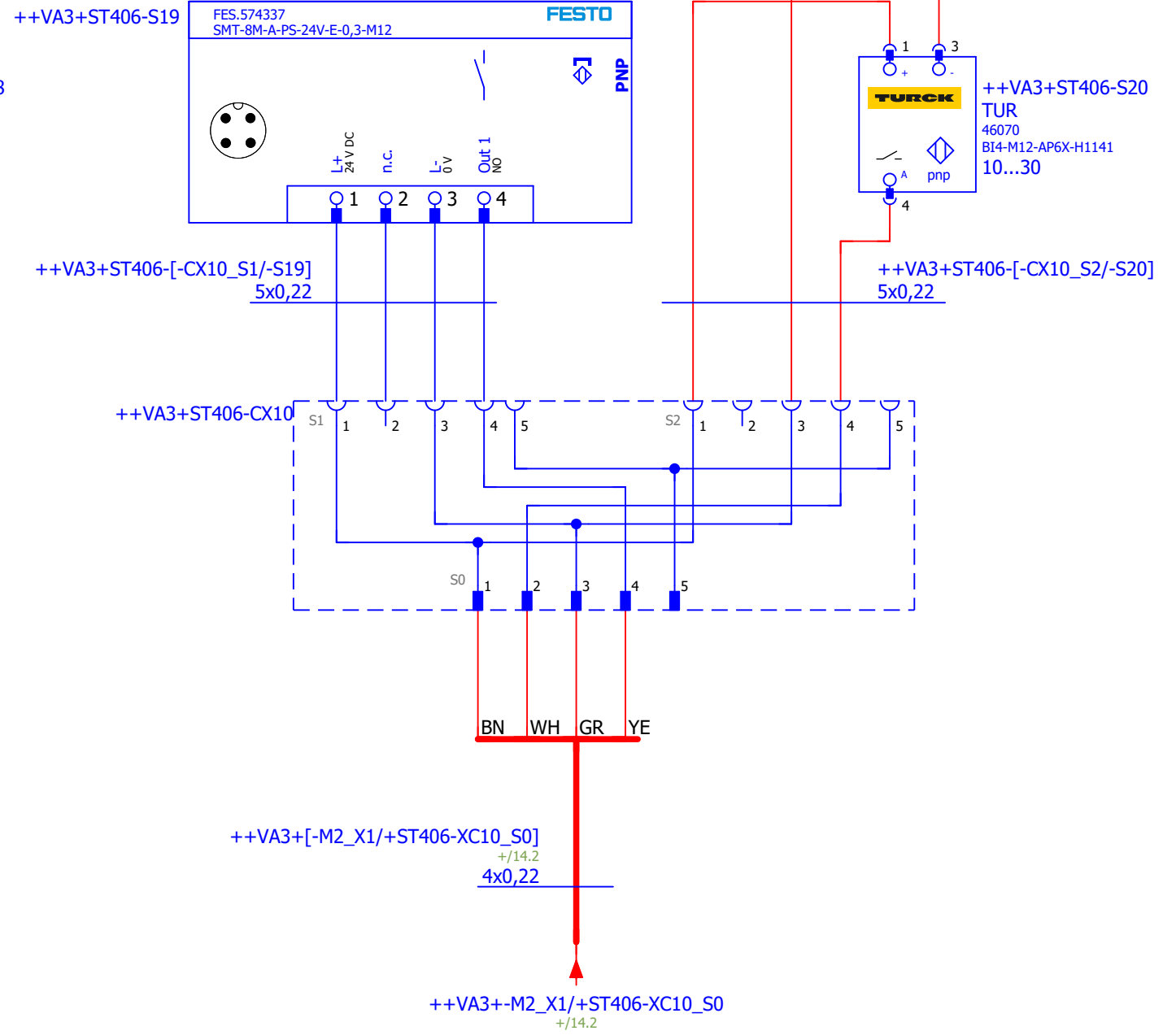
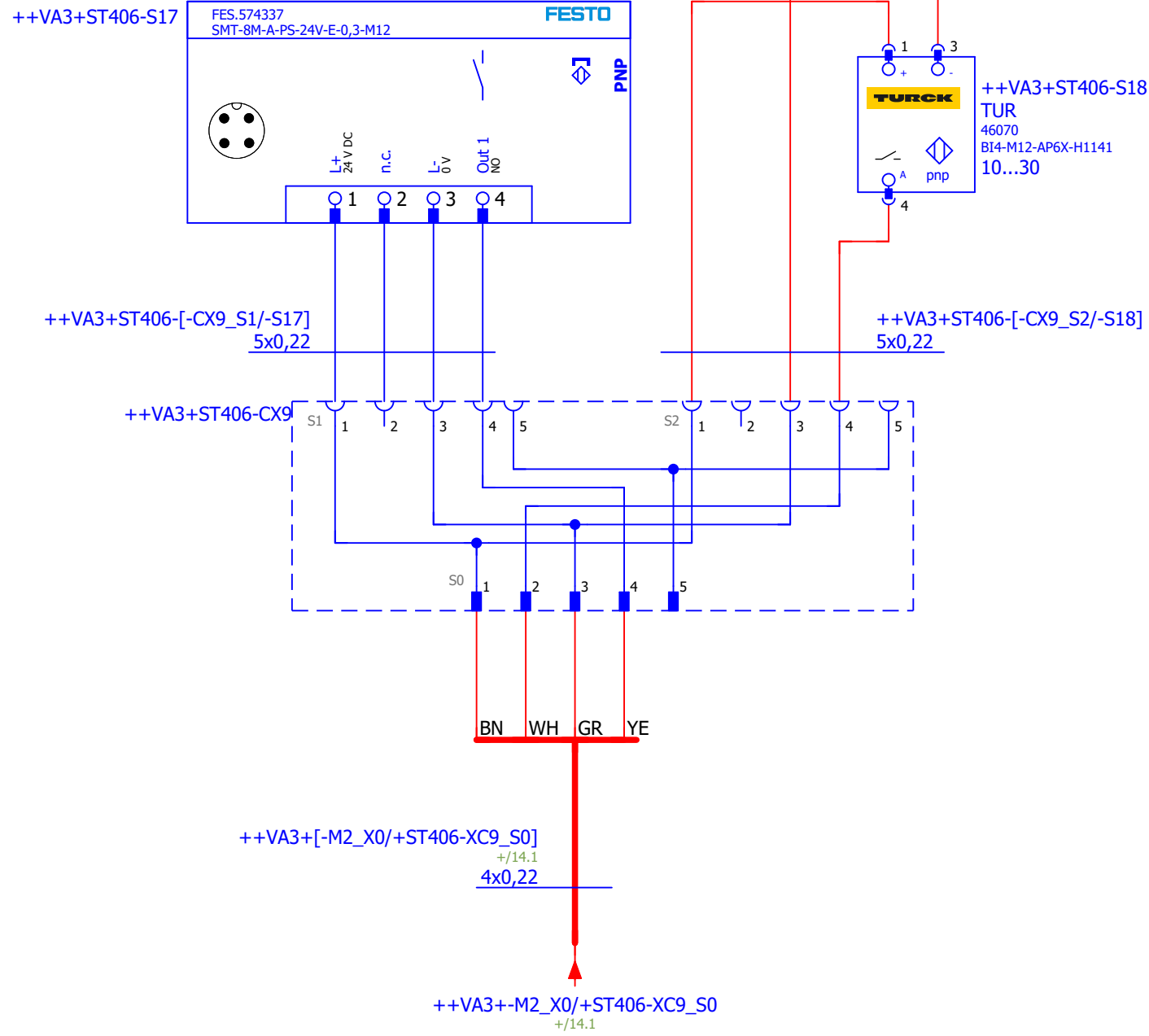

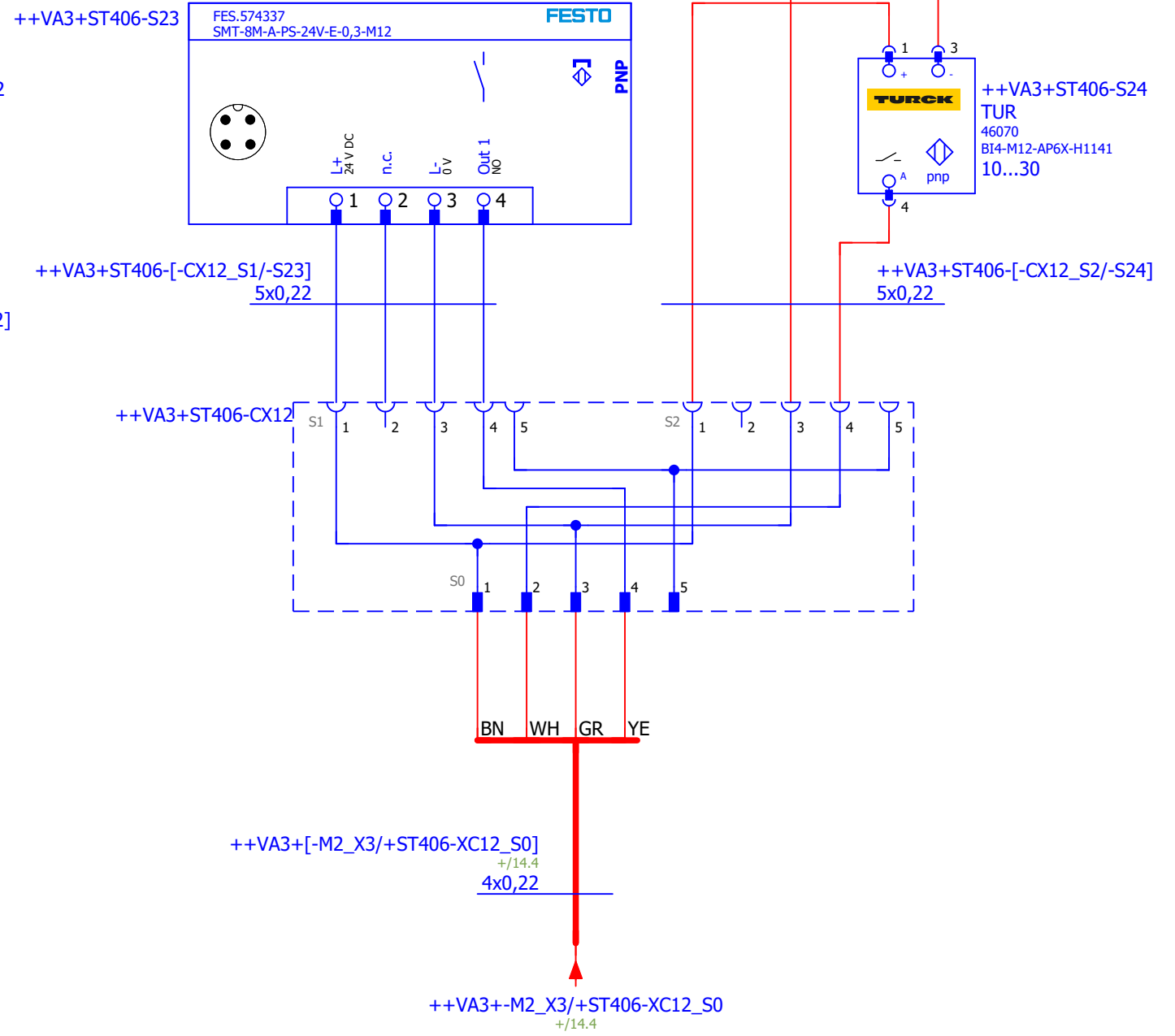
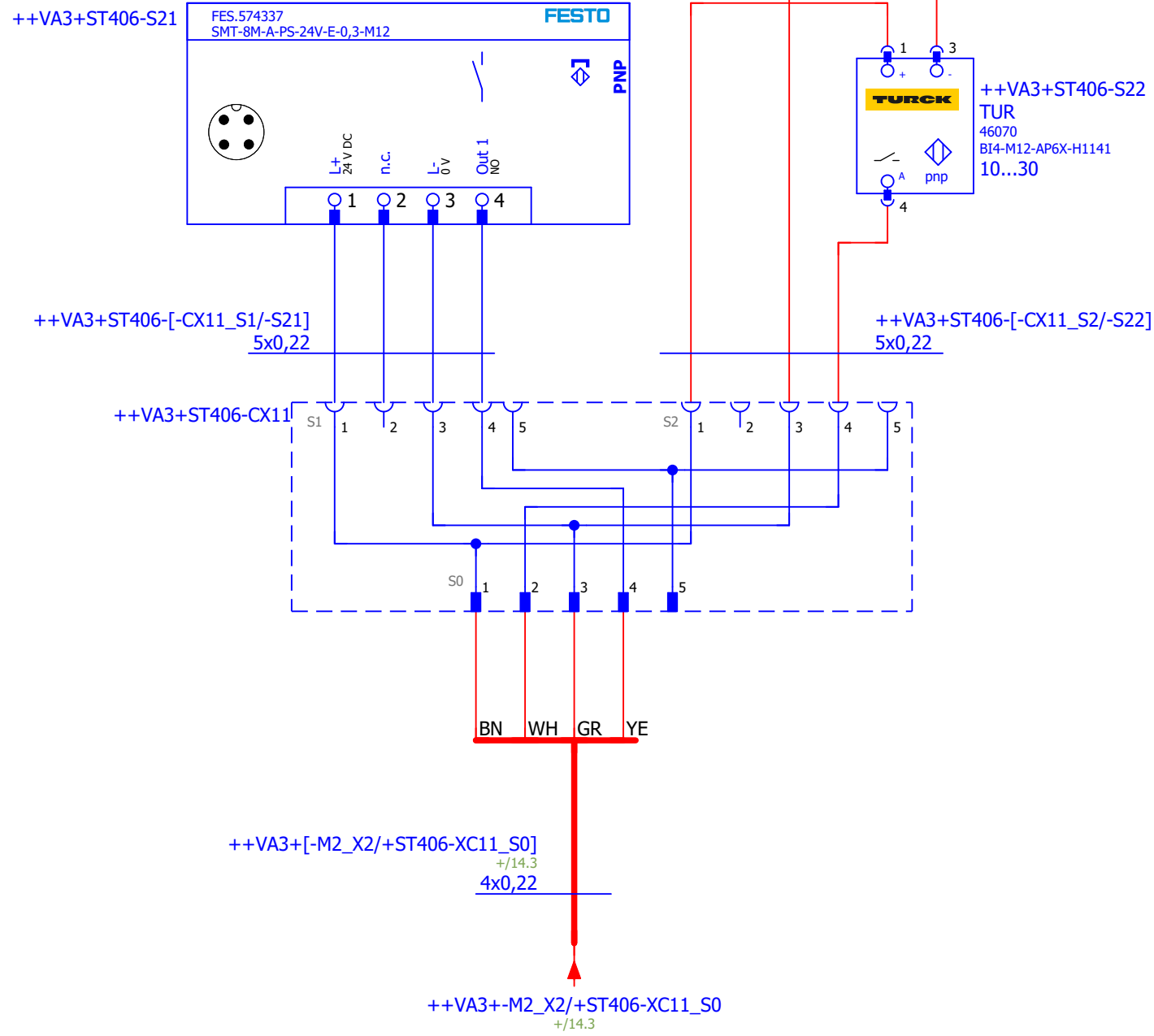

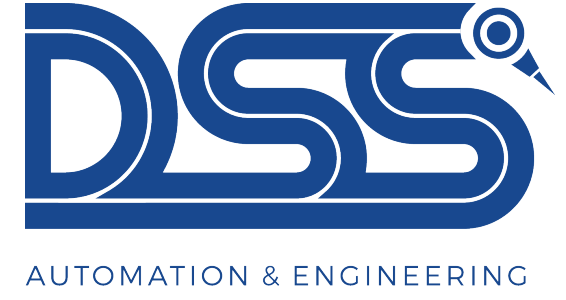

Müşteri : FORD OTOSAN

Üretici (şirket) : DSS OTOMASYON

+ST407



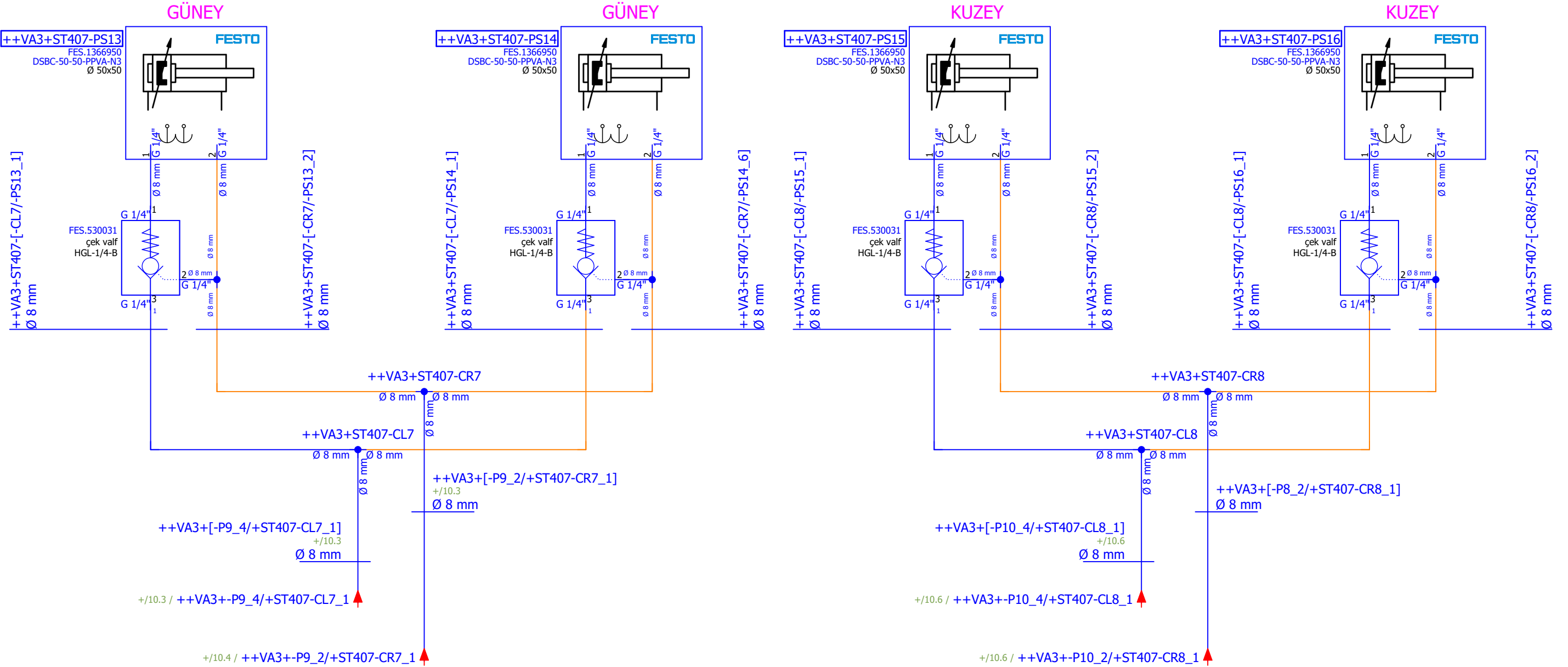

	Yeşilyurt, Muhtar Cafer Sk. No:8 41190 Başiskele/Kocaeli		<b>PROJE ADI</b>	<b>SAYFA AÇIKLAMASI</b>	Çizen: Hasancan Simen	Sayfa 28
	info@dssotomasyon.com.tr		PLC101 stoper	PİSTONLAR	Kontrol Eden: Sabri Ebrem	++VA3
	+90 544 322 23 10					+ST407

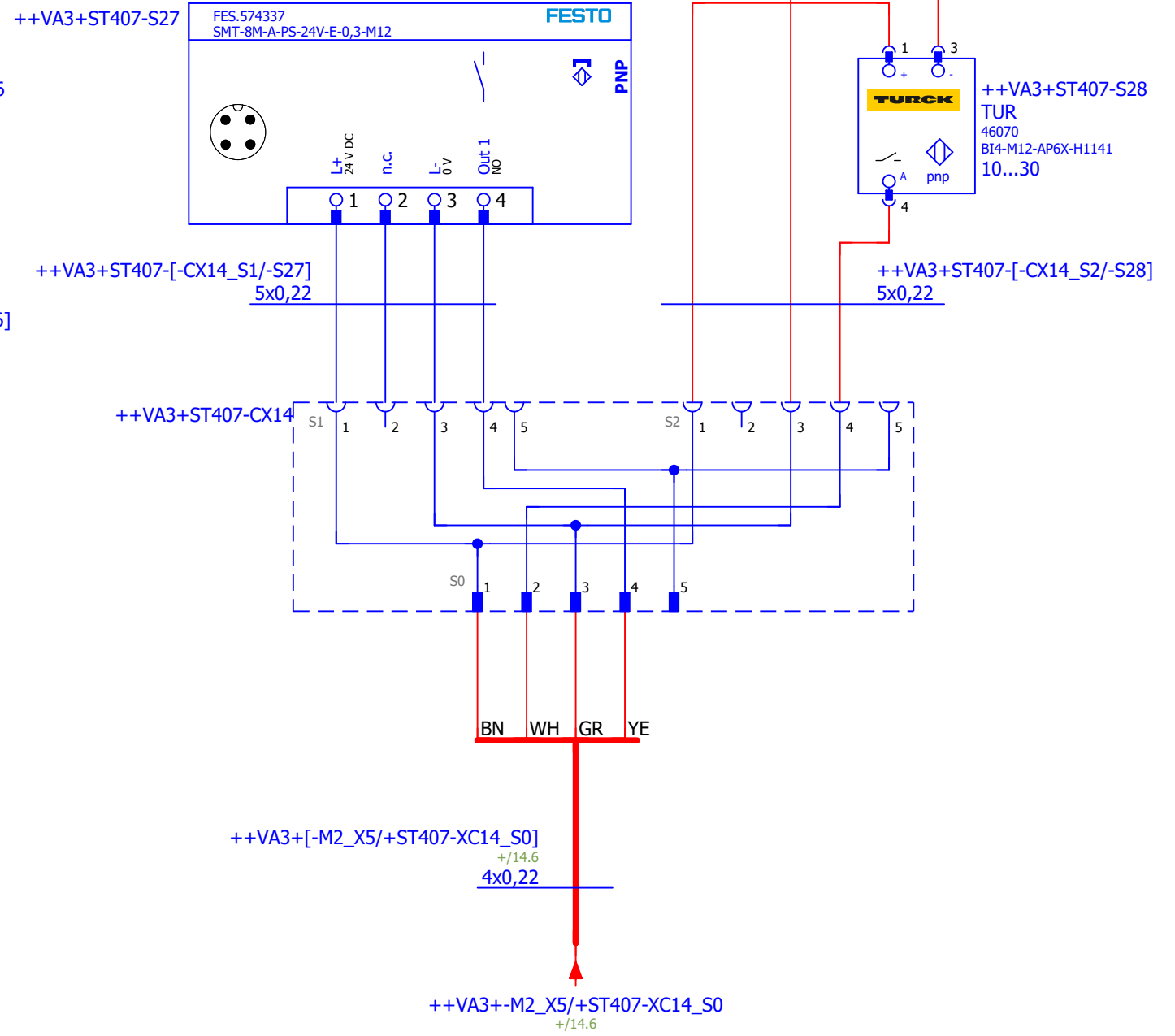
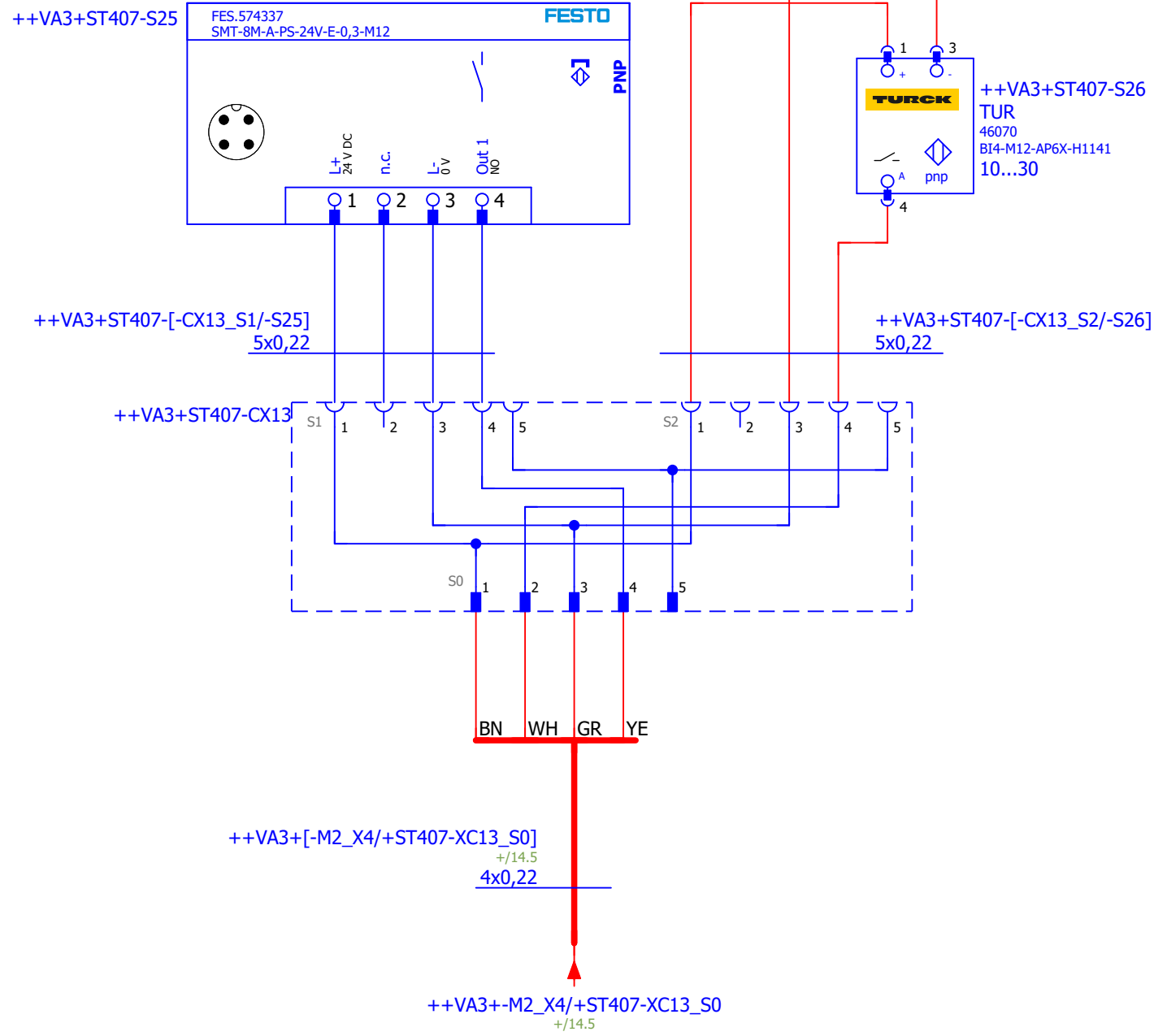

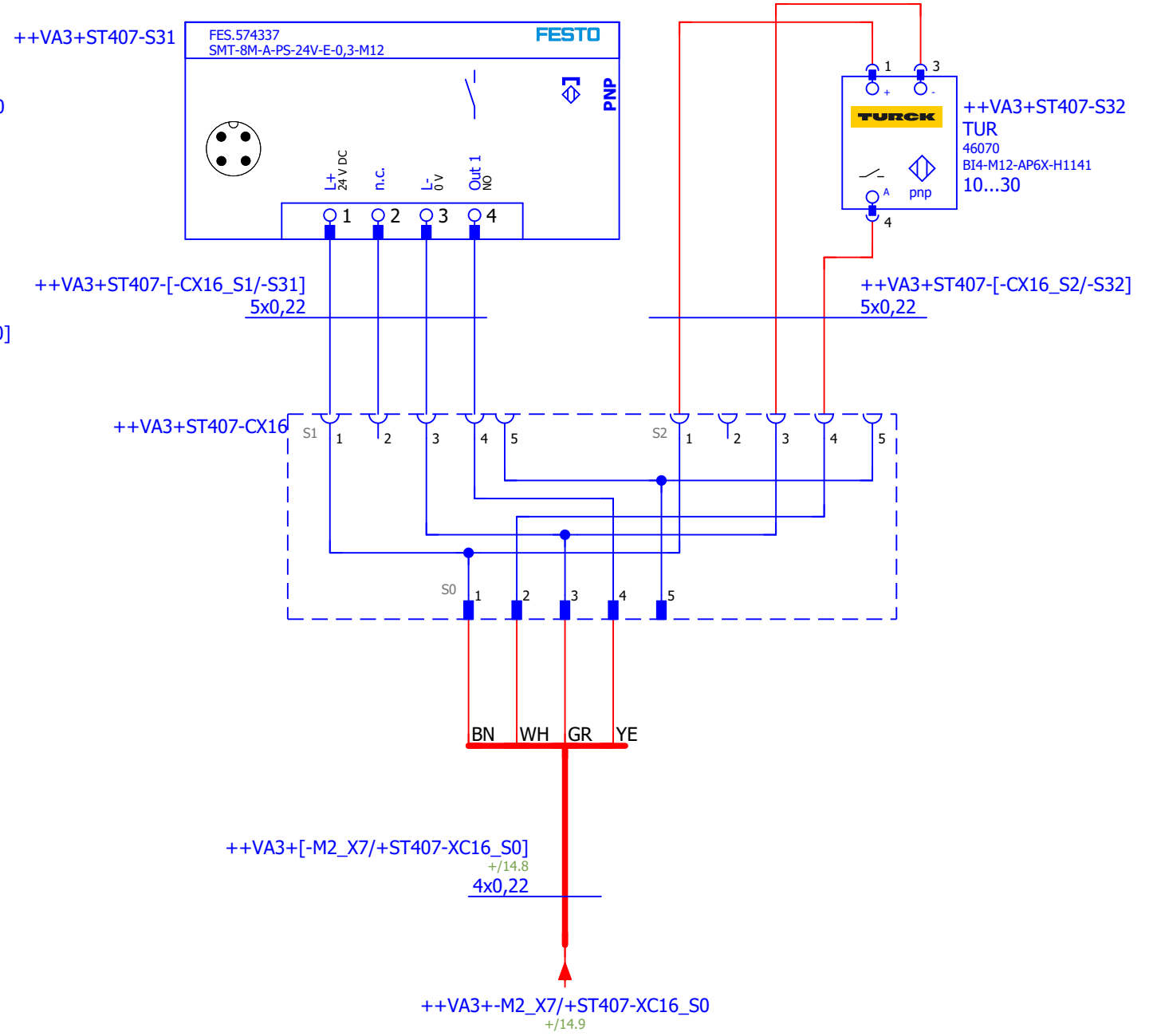
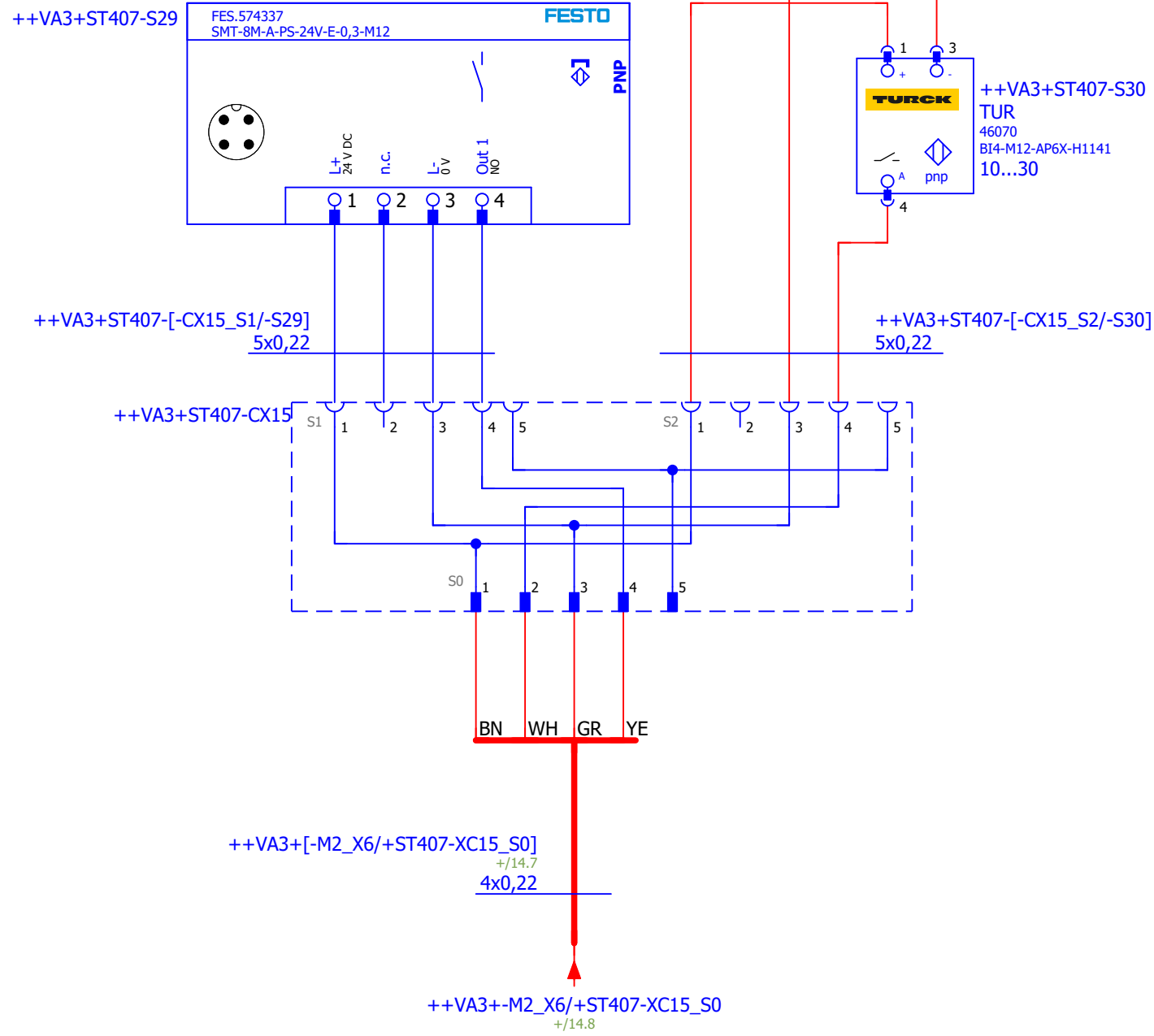

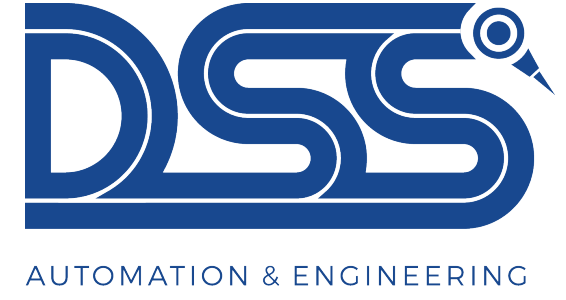

Müşteri : FORD OTOSAN

Üretici (şirket) : DSS OTOMASYON

++VA4



# KUZEY

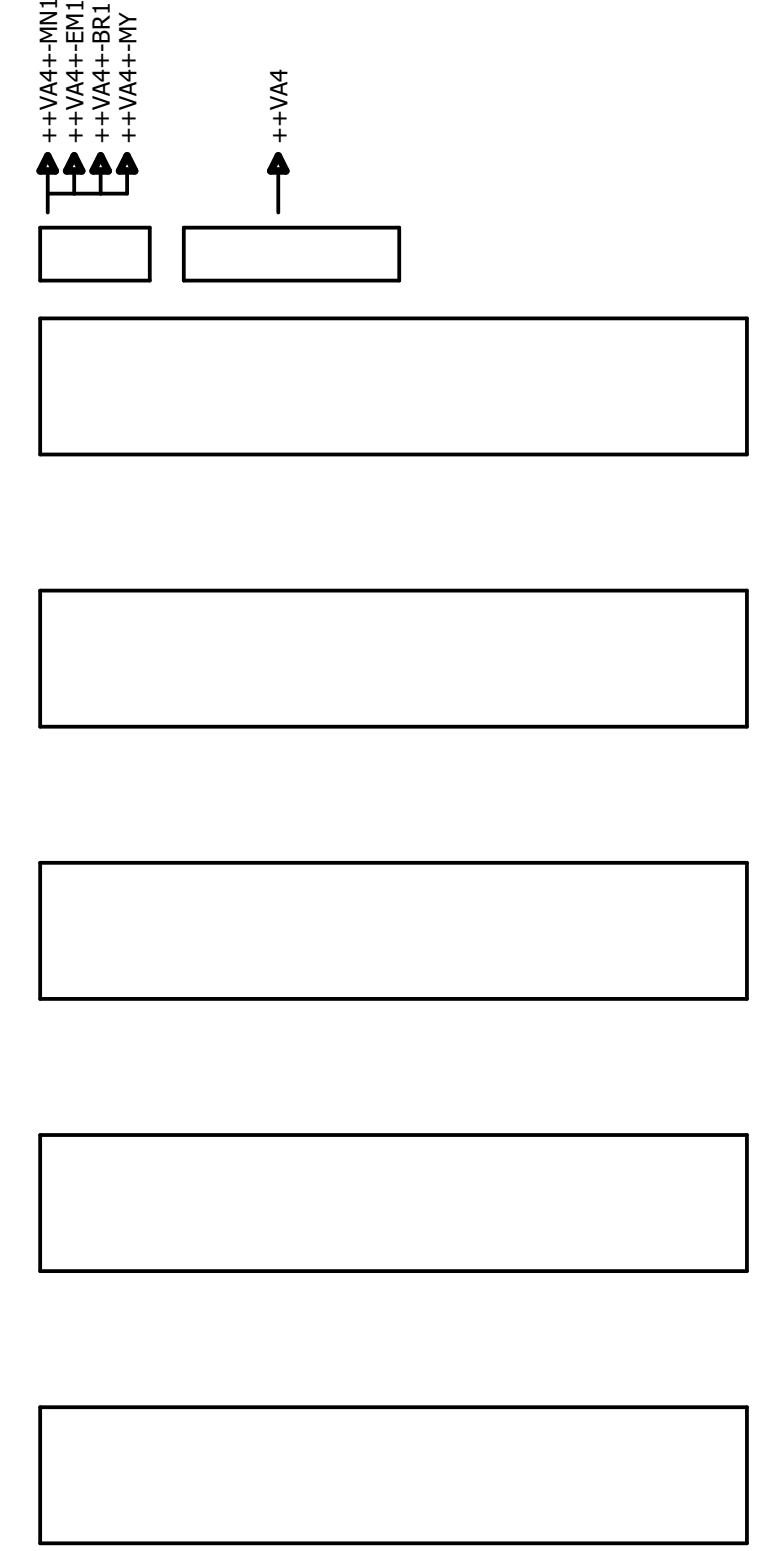
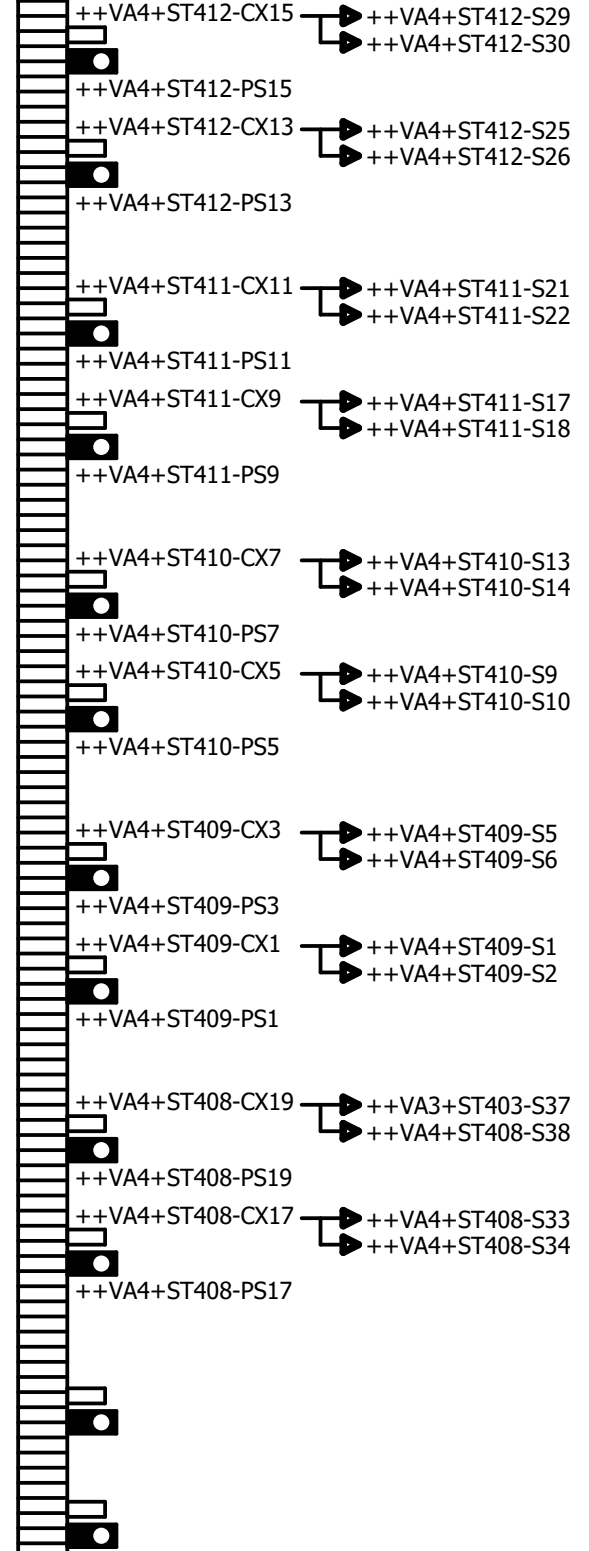
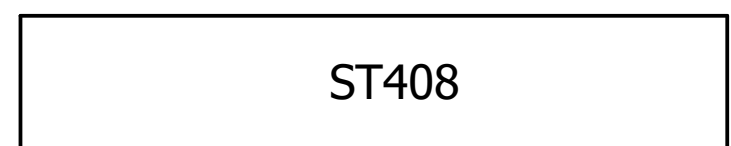
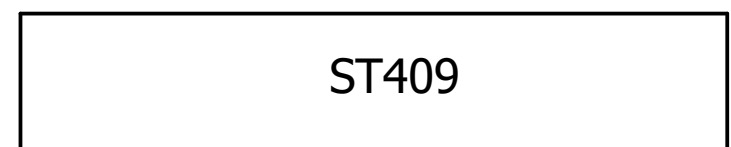
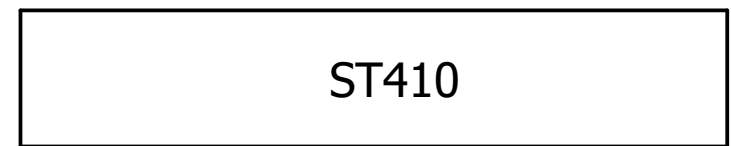
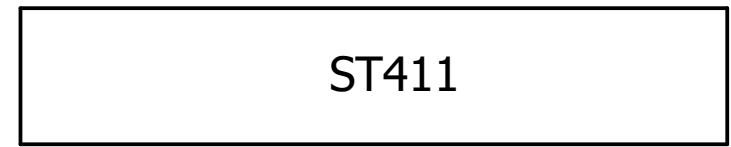
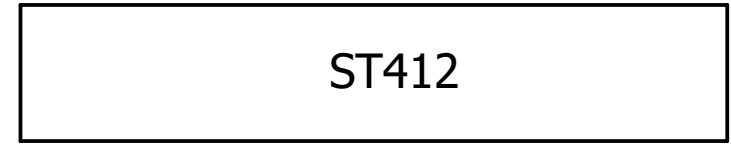
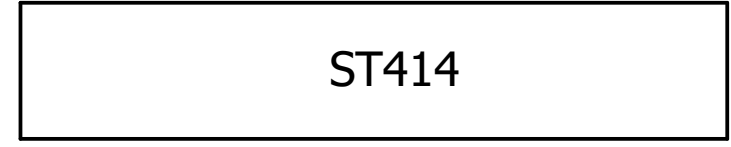
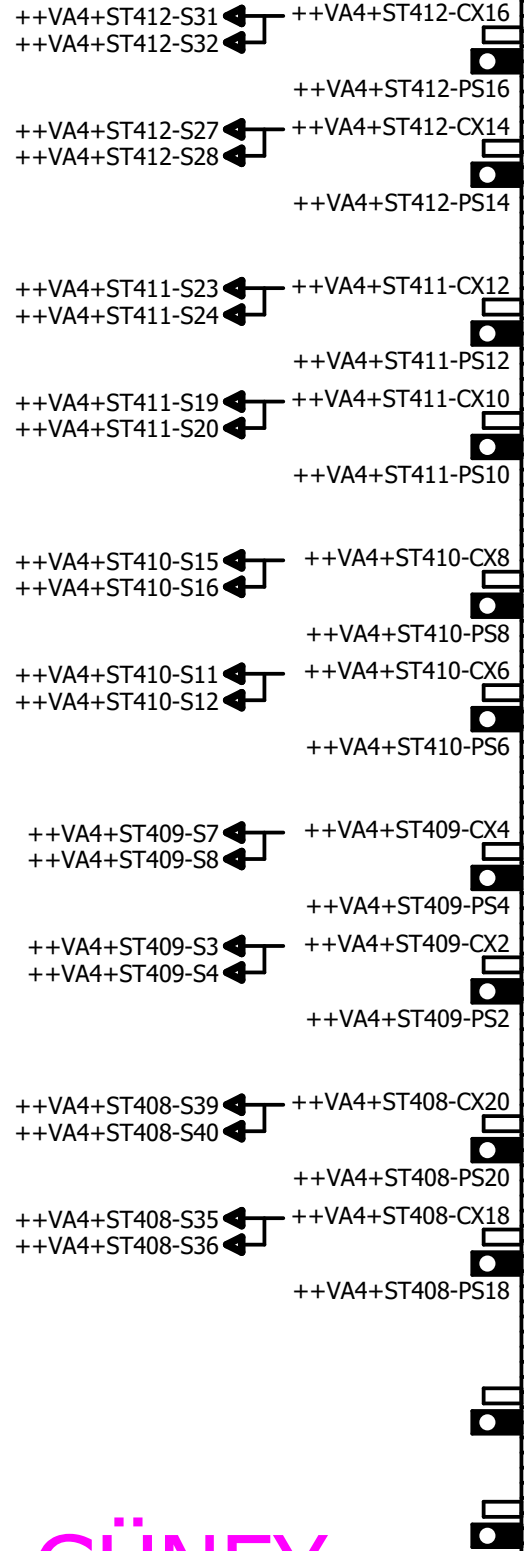

# GÜNEY

1.a

	Yeşilyurt, Muhtar Cafer Sk. No:8 41190 Başiskele/Kocaeli		<b>PROJE ADI</b>	<b>SAYFA AÇIKLAMASI</b>	Çizen: Hasancan Simen	Sayfa 1.a
	info@dssotomasyon.com.tr		PLC101 stoper	LAYOUT	Kontrol Eden: Sabri Ebrem	++VA4 +
AUTOMATION & ENGINEERING	+90 544 322 23 10					

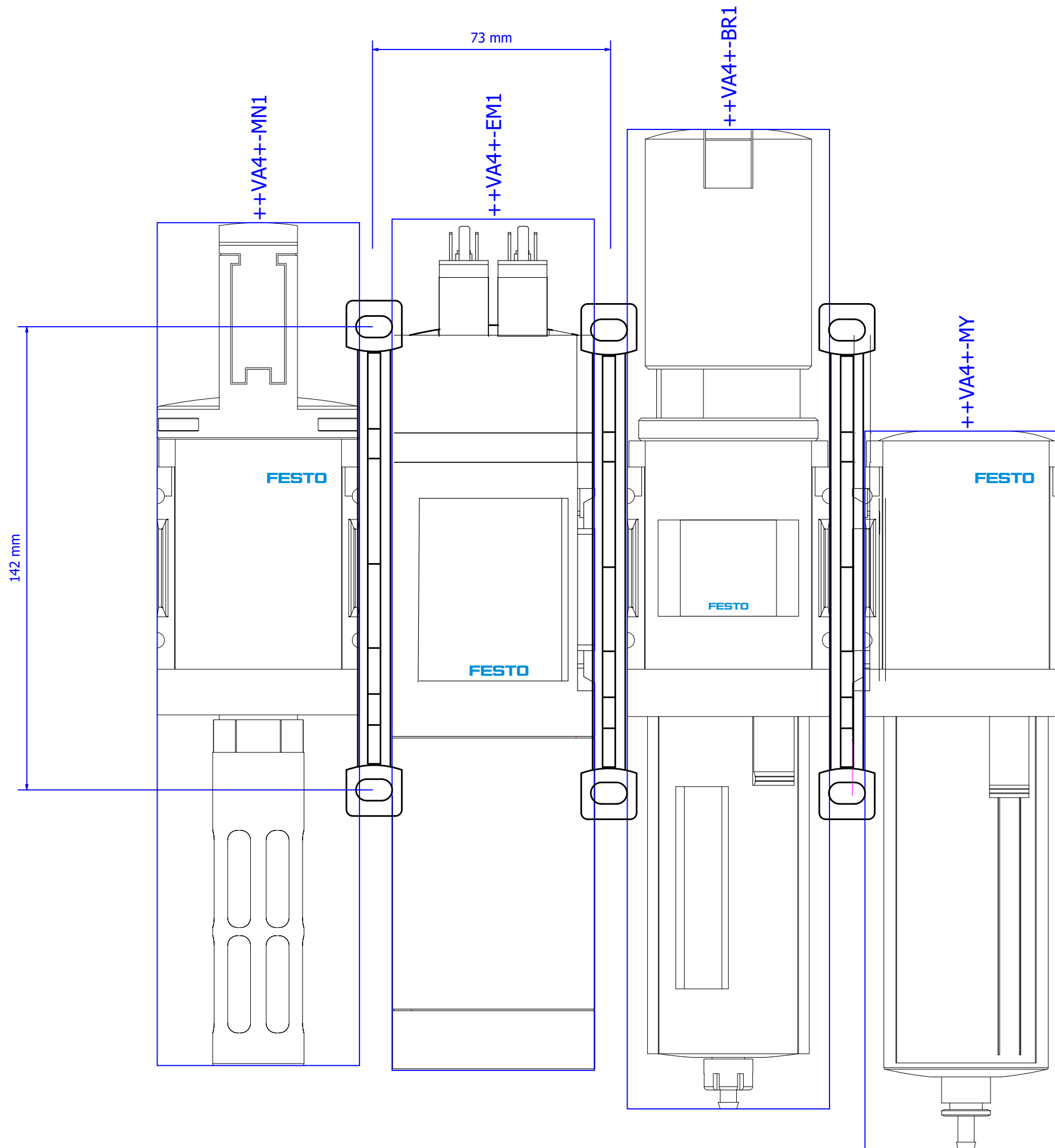

2



<b>PROJE ADI</b>	PLC101 stoper
------------------	---------------

<b>SAYFA AÇIKLAMASI</b>	MOTAJ PLAKASI
-------------------------	---------------

Çizen:	Hasancan Simen
Kontrol Eden:	Sabri Ebrem

++VA4	
+	

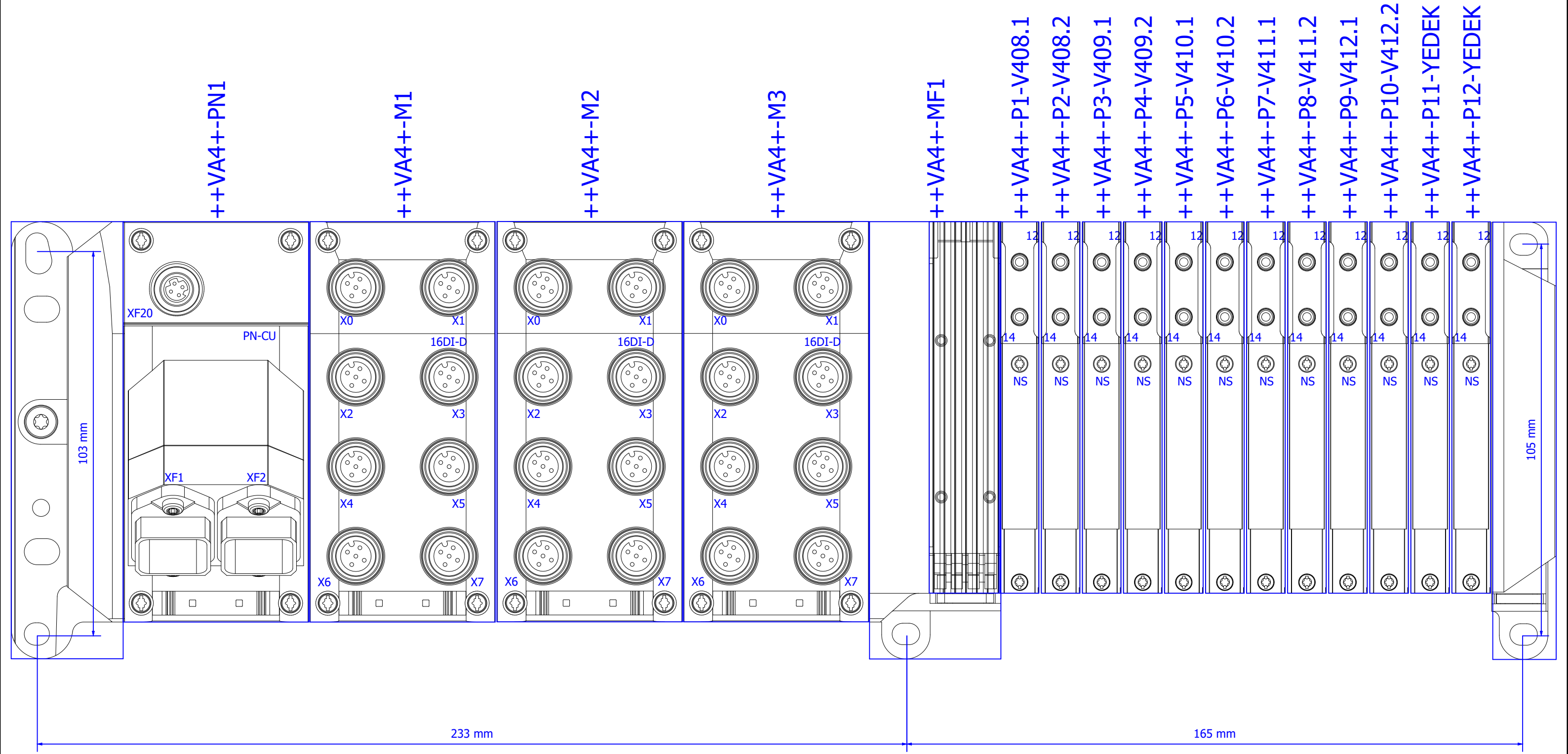

	Yeşilyurt, Muhtar Cafer Sk. No:8 41190 Başiskele/Kocaeli		<b>PROJE ADI</b>	<b>SAYFA AÇIKLAMASI</b>	Çizen: Hasancan Simen	Sayfa 3
	info@dssotomasyon.com.tr		PLC101 stoper	MOTAJ PLAKASI	Kontrol Eden: Sabri Ebrem	++VA4 +

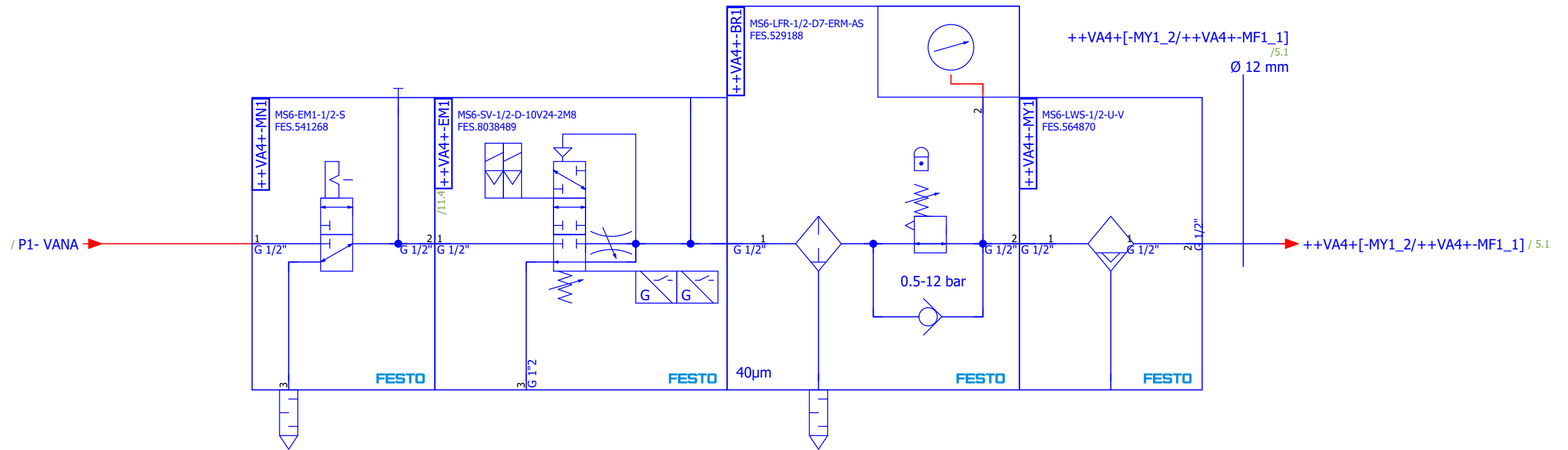

<b>PROJE ADI</b>	PLC101 stoper
------------------	---------------

<b>SAYFA AÇIKLAMASI</b>	ŞARTLANDIRICI
-------------------------	---------------

Çizen:	Hasancan Simen
Kontrol Eden:	Sabri Ebrem

++VA4	
+	

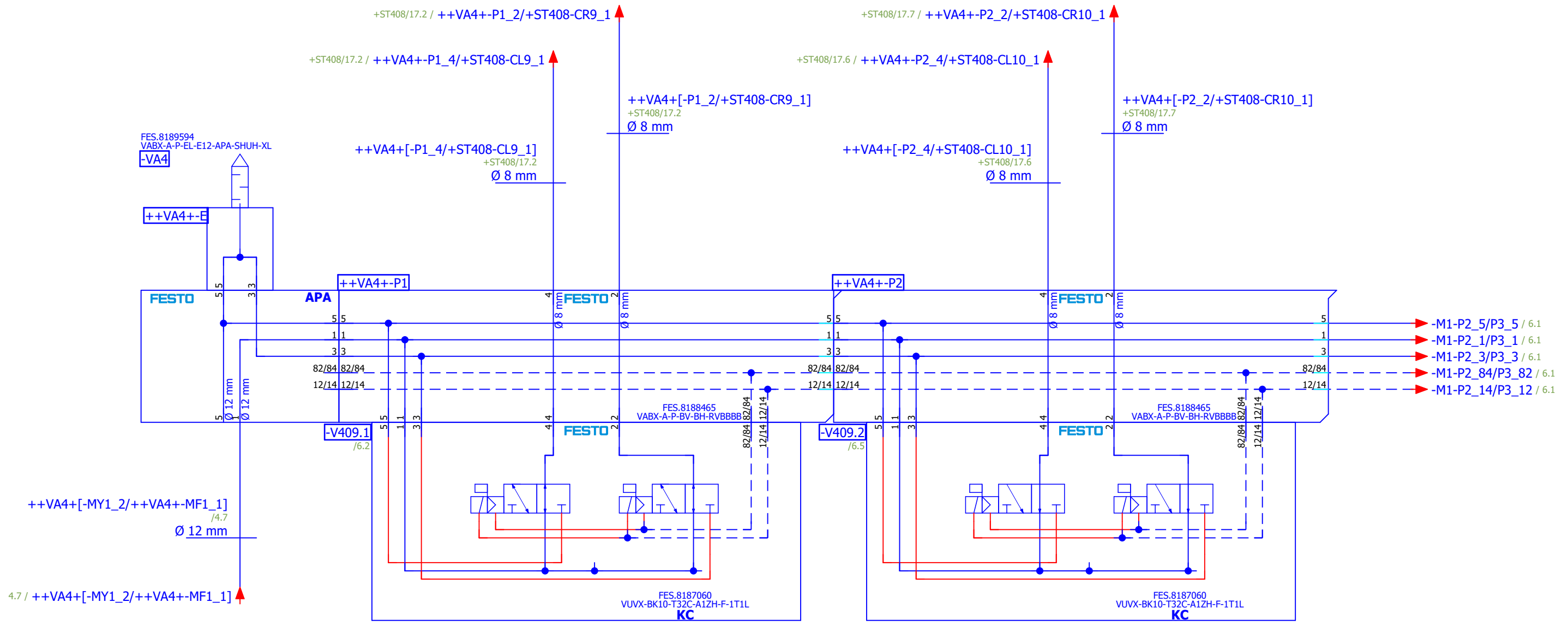

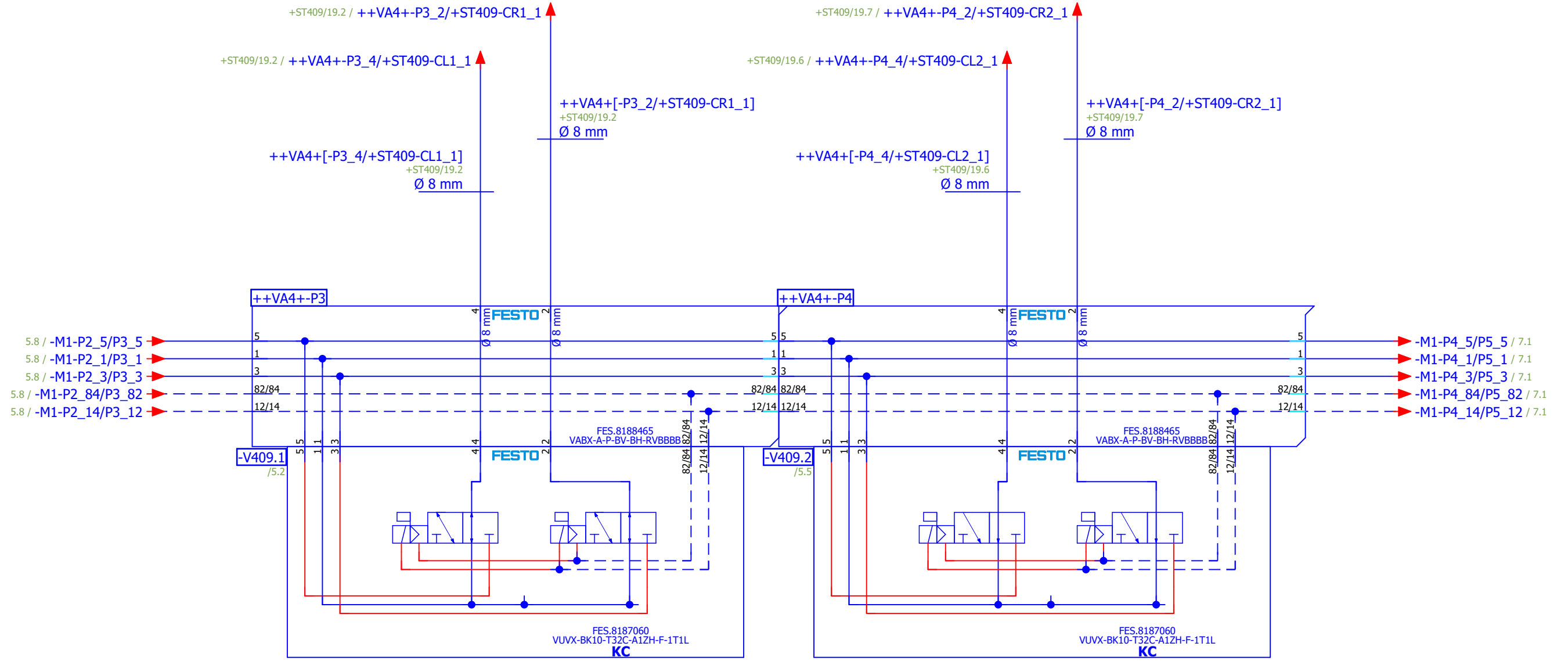

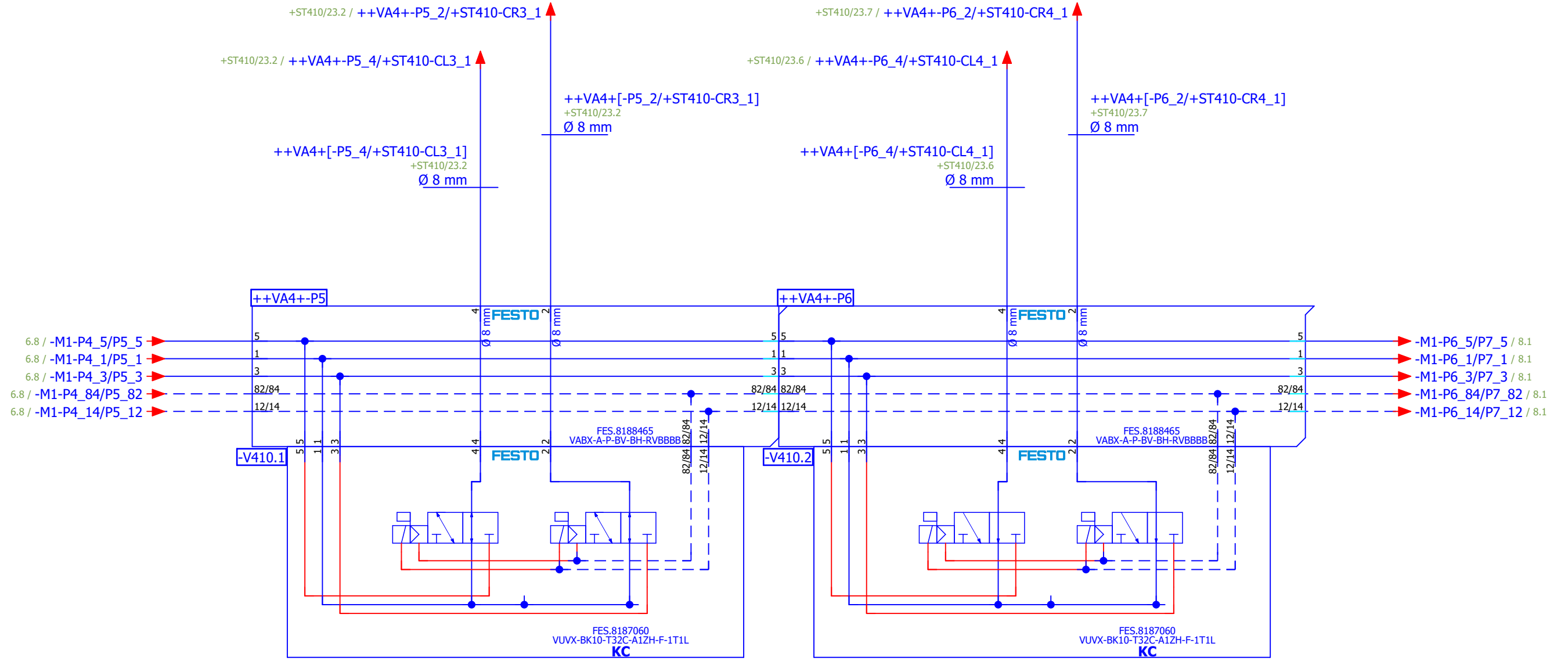

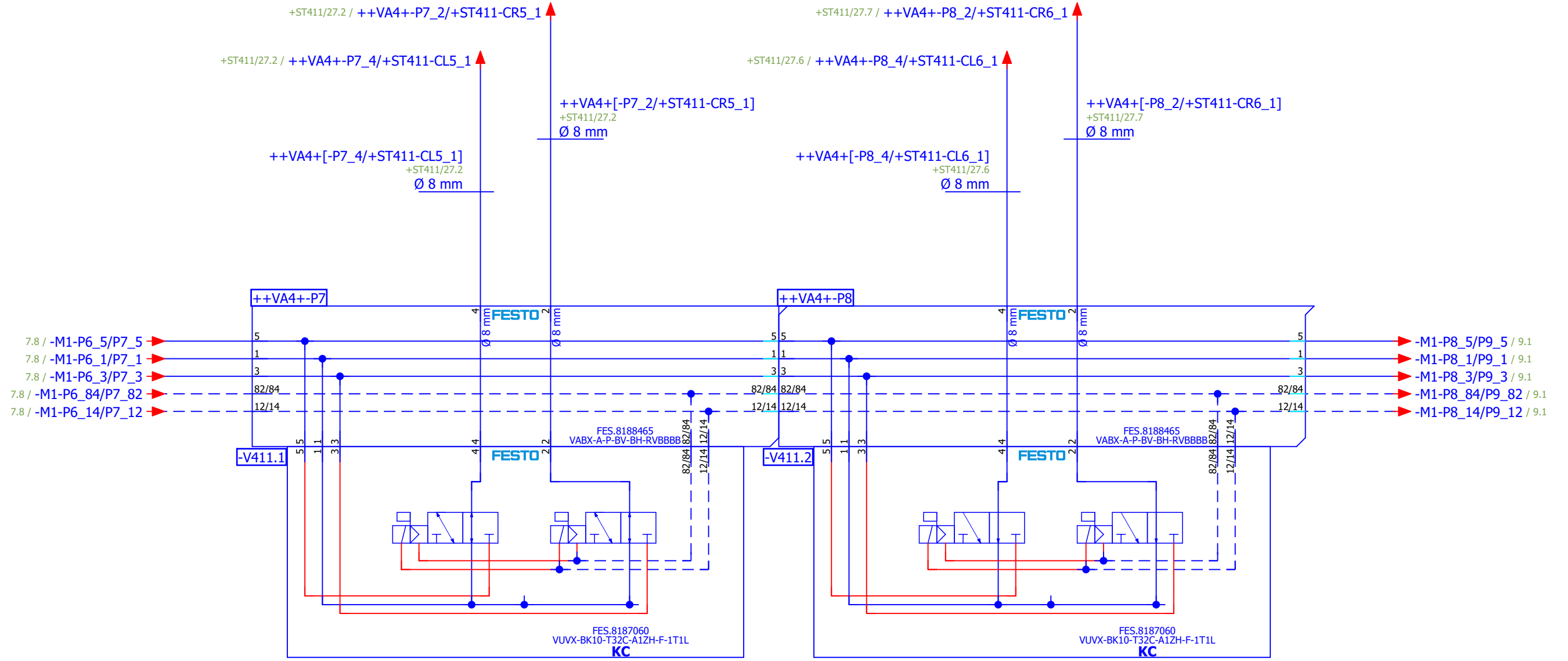

6.8 / -M1-P4\_5/P5\_5  
 6.8 / -M1-P4\_1/P5\_1  
 6.8 / -M1-P4\_3/P5\_3  
 6.8 / -M1-P4\_84/P5\_82  
 6.8 / -M1-P4\_14/P5\_12

-M1-P6\_5/P7\_5 / 8.1  
 -M1-P6\_1/P7\_1 / 8.1  
 -M1-P6\_3/P7\_3 / 8.1  
 -M1-P6\_84/P7\_82 / 8.1  
 -M1-P6\_14/P7\_12 / 8.1



	Yeşilyurt, Muhtar Cafer Sk. No:8 41190 Başiskele/Kocaeli		<b>PROJE ADI</b>	<b>SAYFA AÇIKLAMASI</b>	Çizen: Hasancan Simen	Sayfa 8
	info@dssotomasyon.com.tr		PLC101 stoper	-VA4-V411	Kontrol Eden: Sabri Ebrem	
	+90 544 322 23 10					



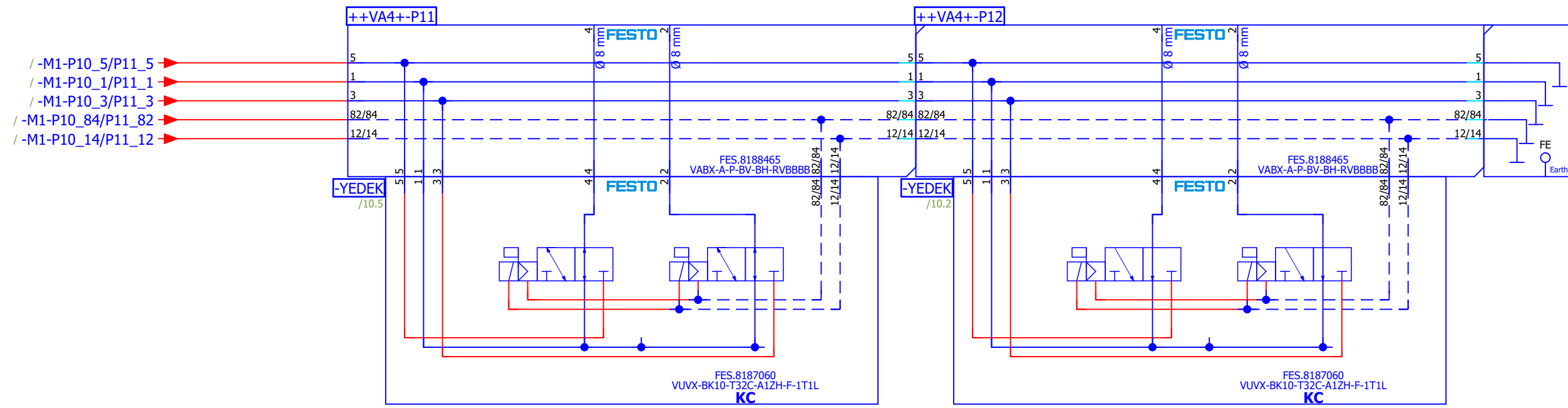

	Yeşilyurt, Muhtar Cafer Sk. No:8 41190 Başiskele/Kocaeli		<b>PROJE ADI</b>	<b>SAYFA AÇIKLAMASI</b>	Çizen: Hasancan Simen	Sayfa 10
	info@dssotomasyon.com.tr		PLC101 stoper	-VA4-YEDEK	Kontrol Eden: Sabri Ebrem	++VA4
	+90 544 322 23 10					+

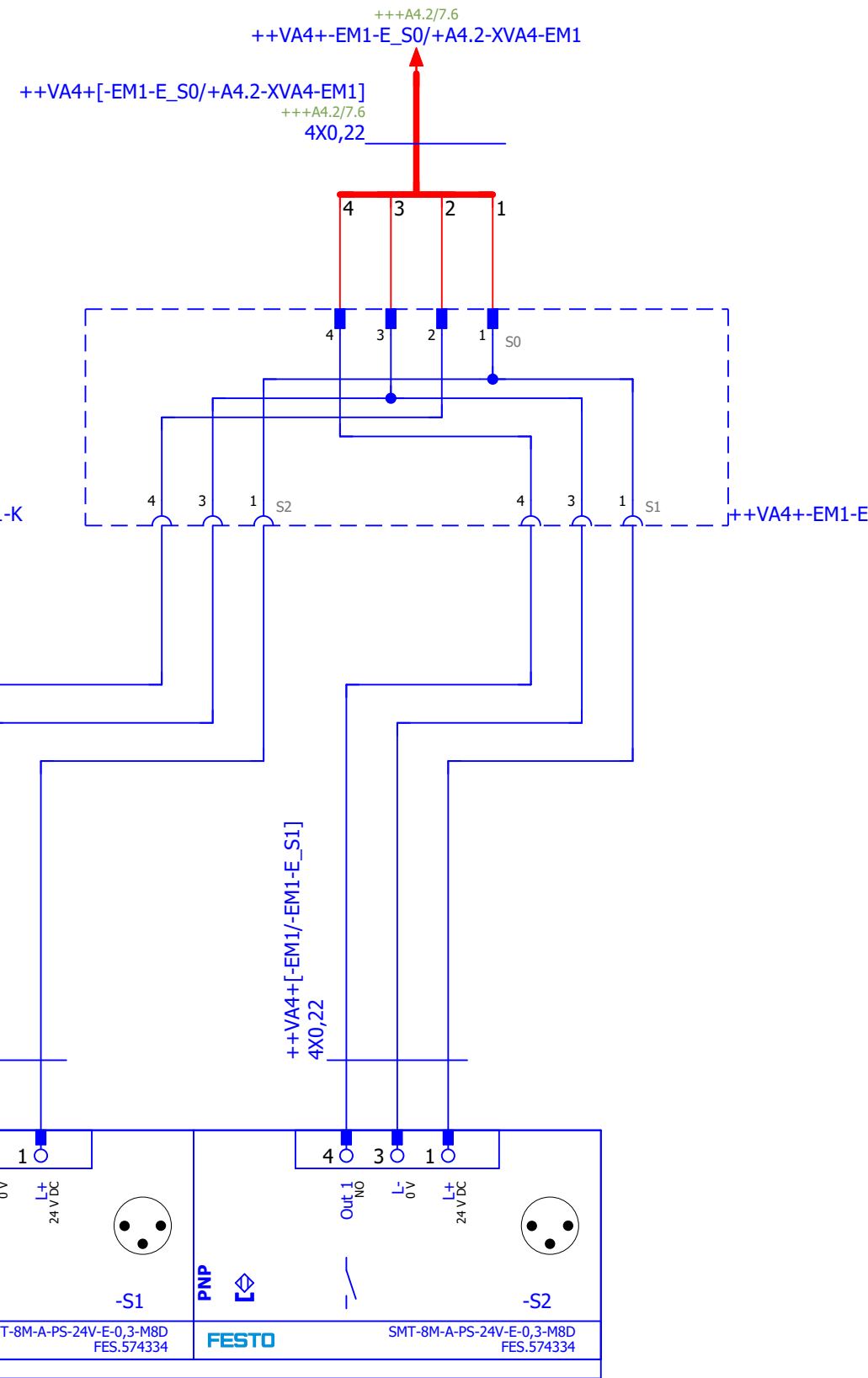
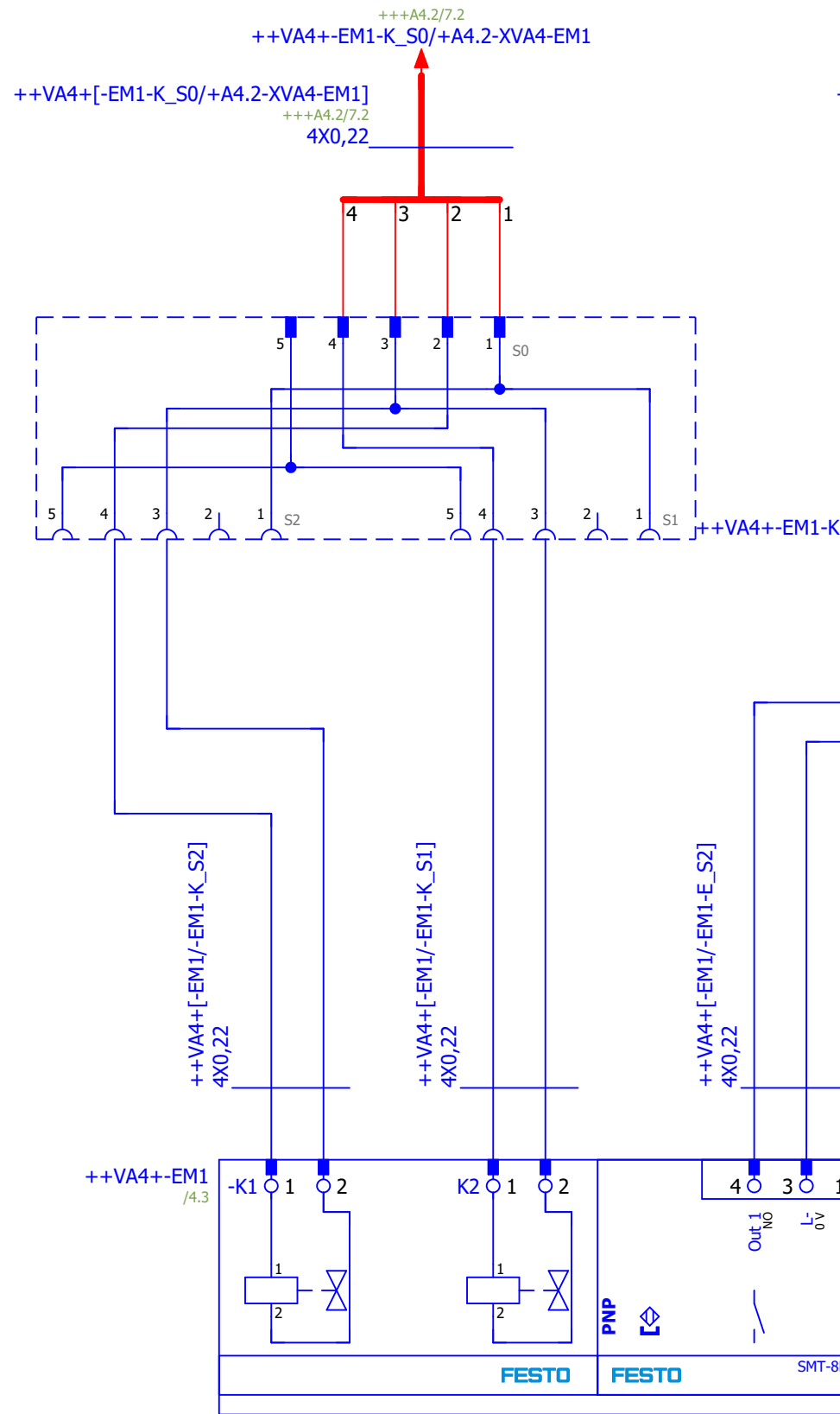
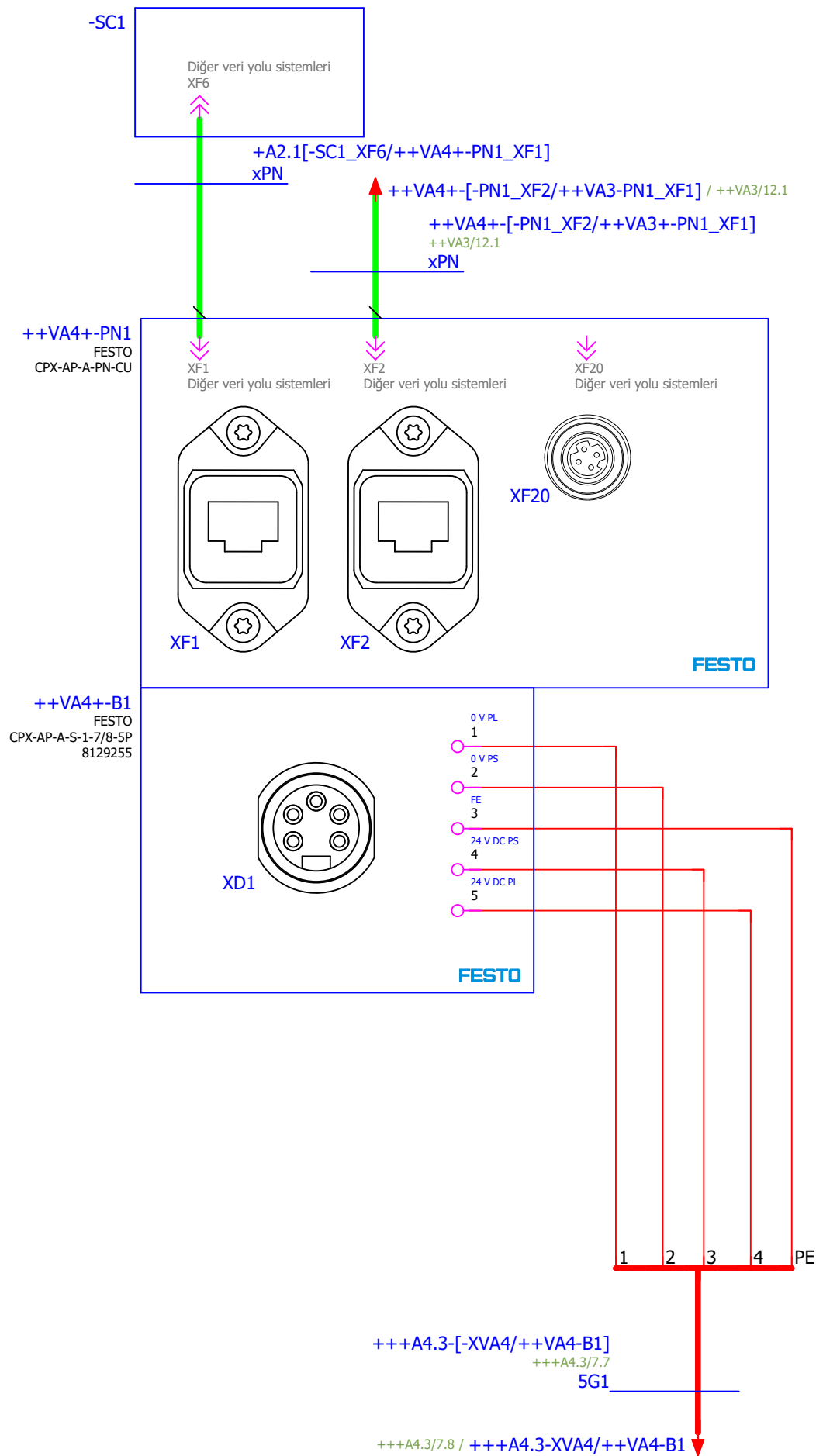

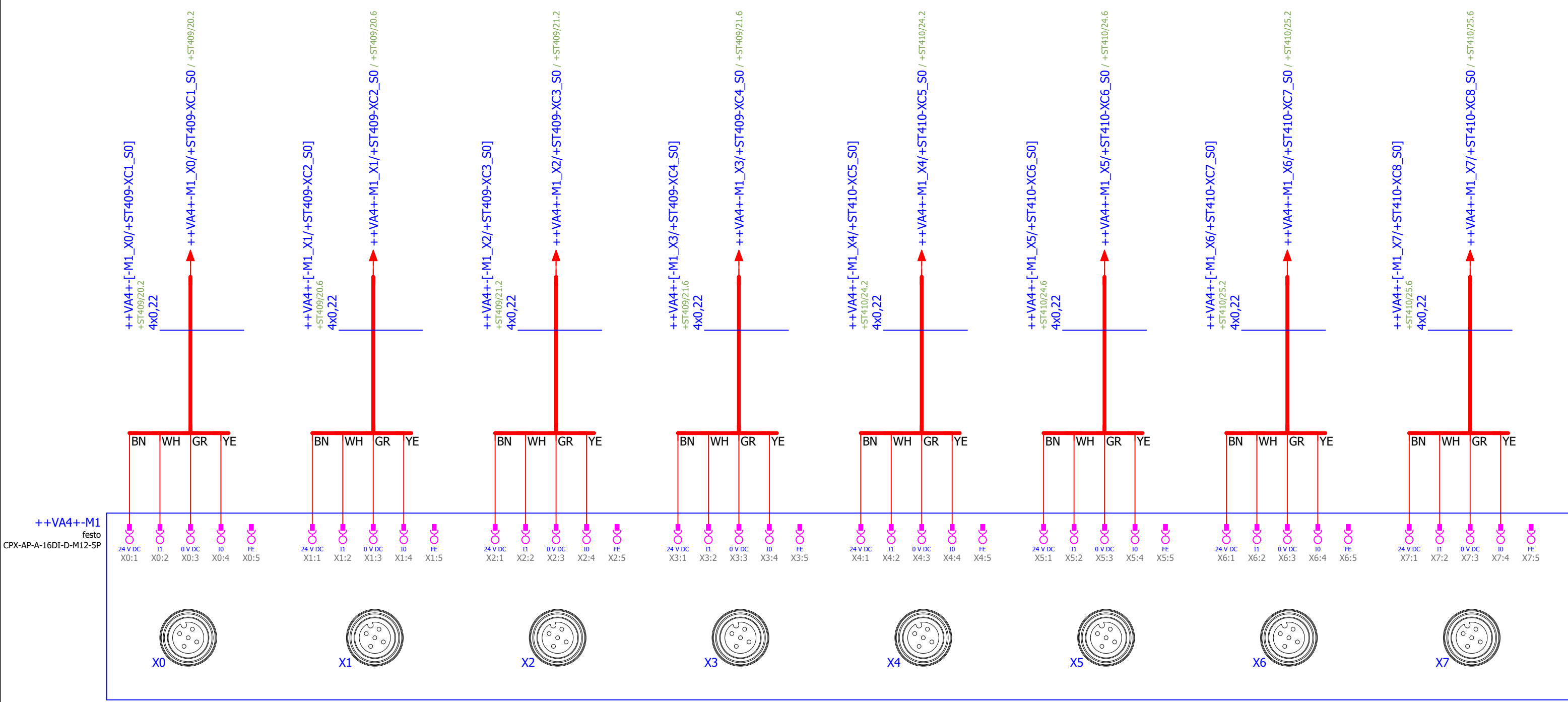

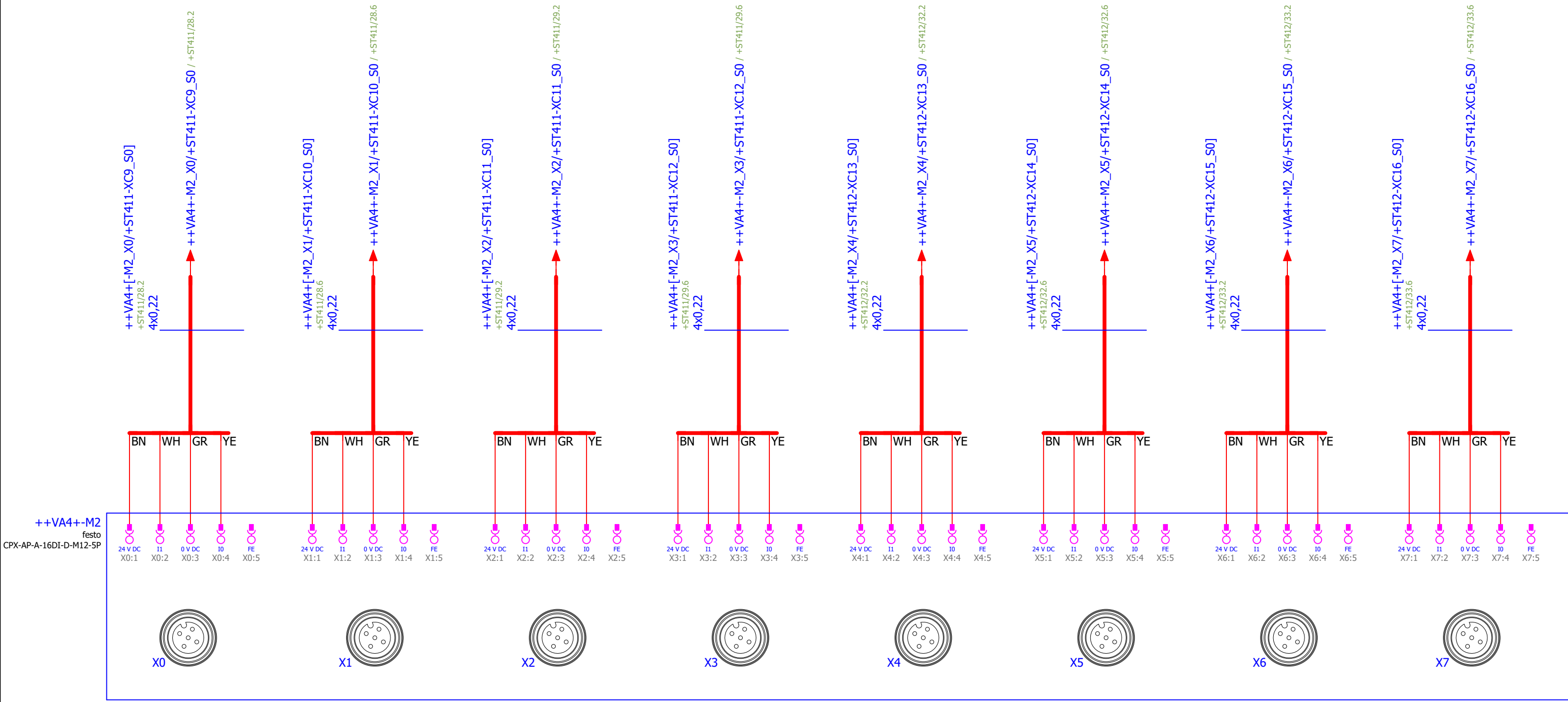

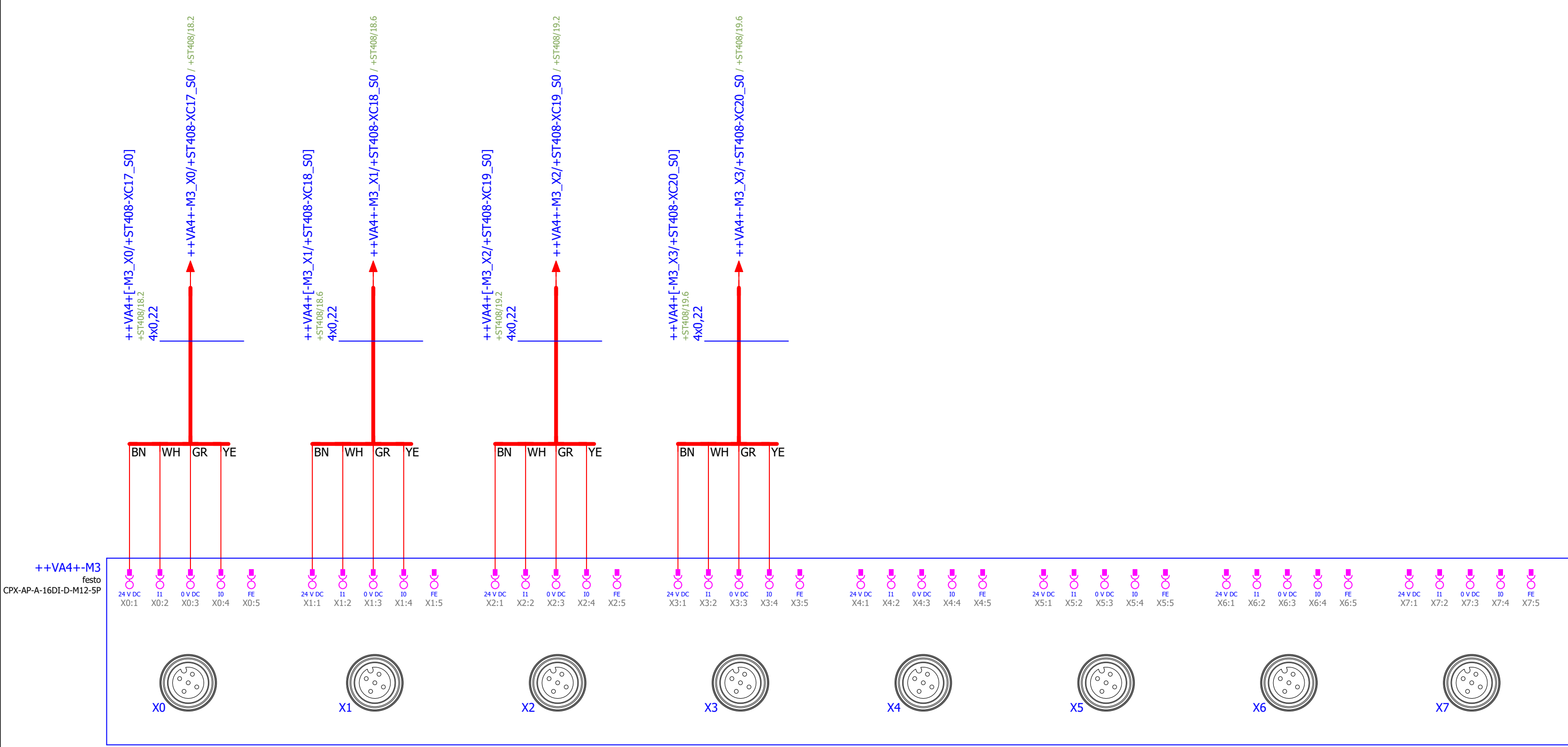

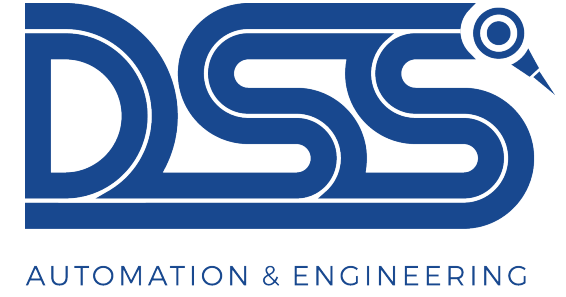

Müşteri : FORD OTOSAN

Üretici (şirket) : DSS OTOMASYON

+ST408



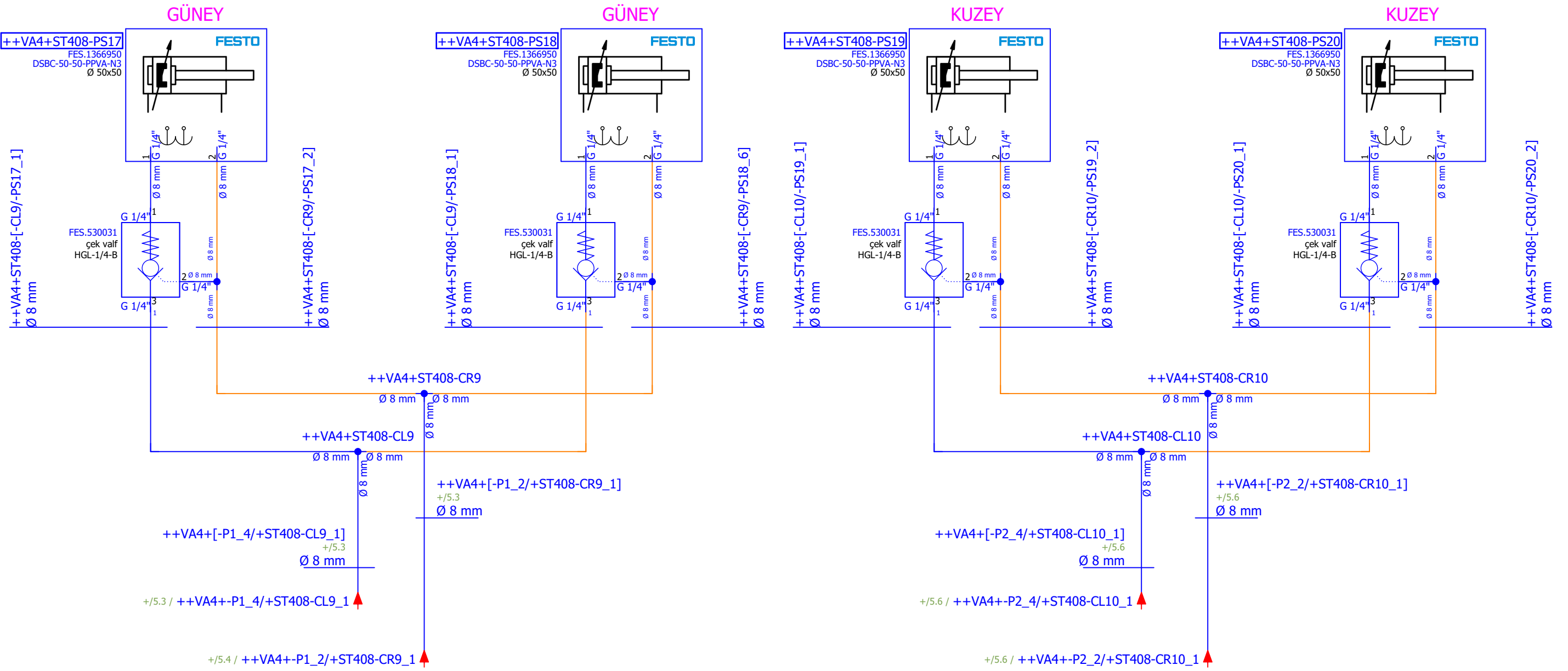

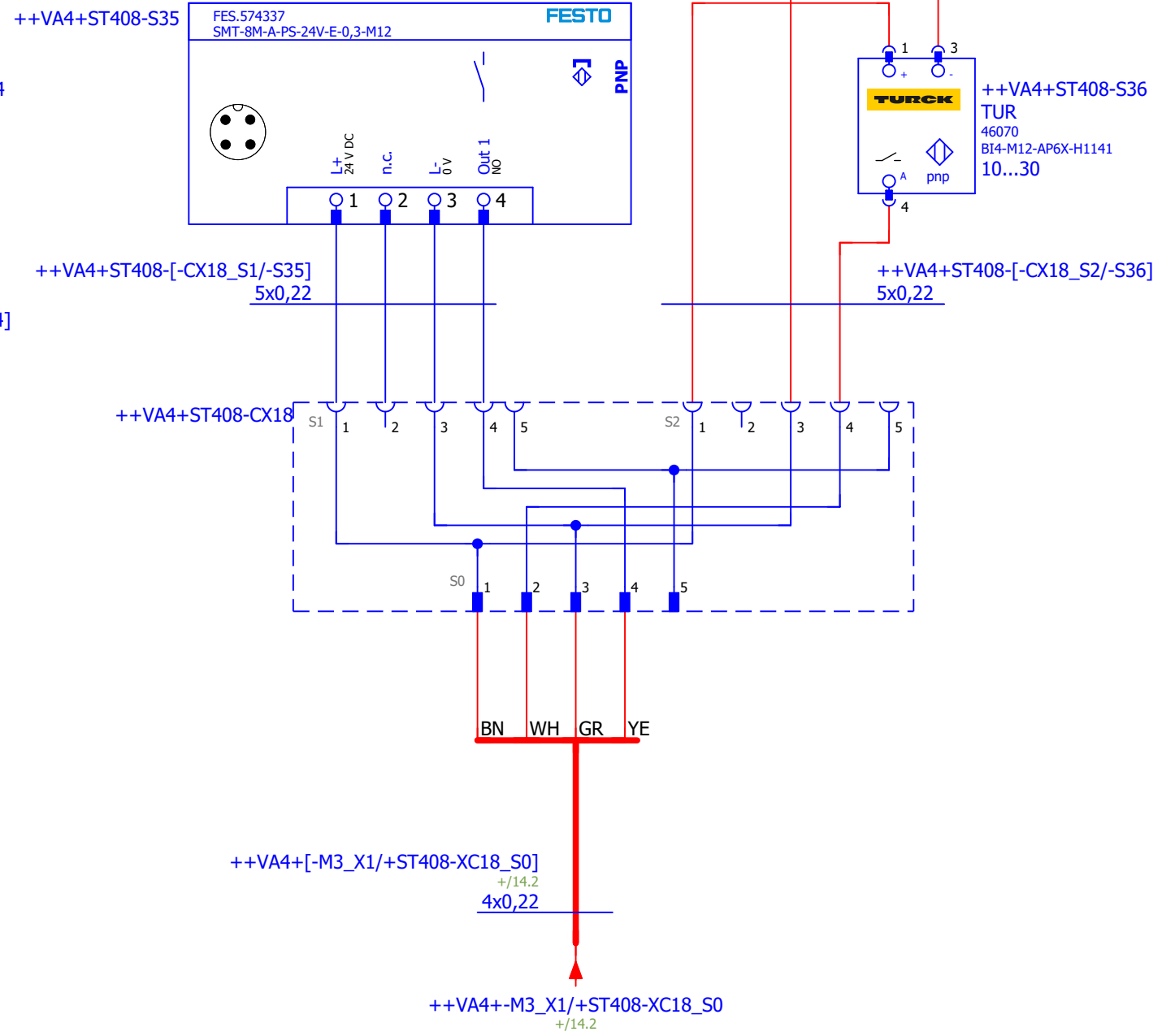
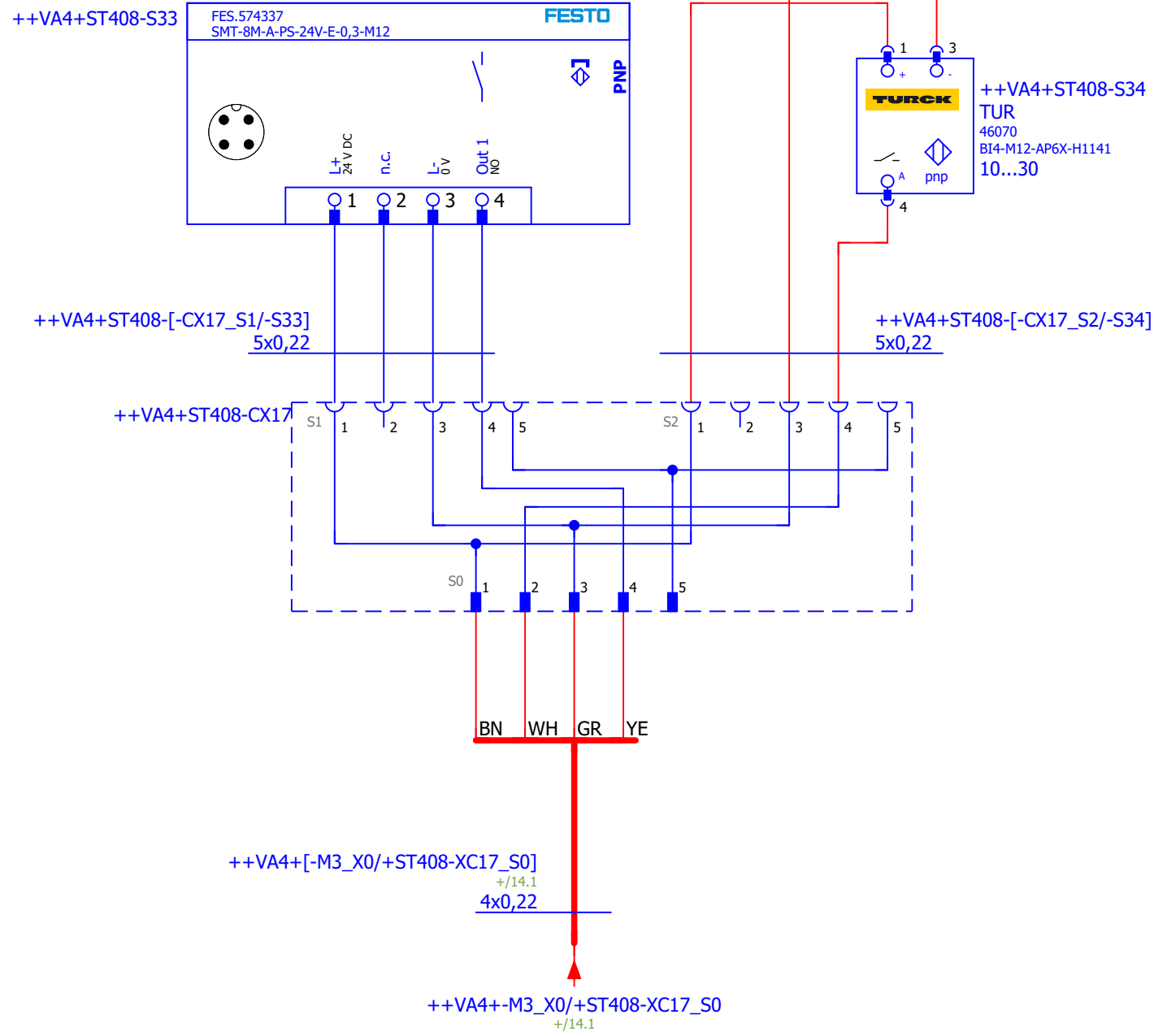

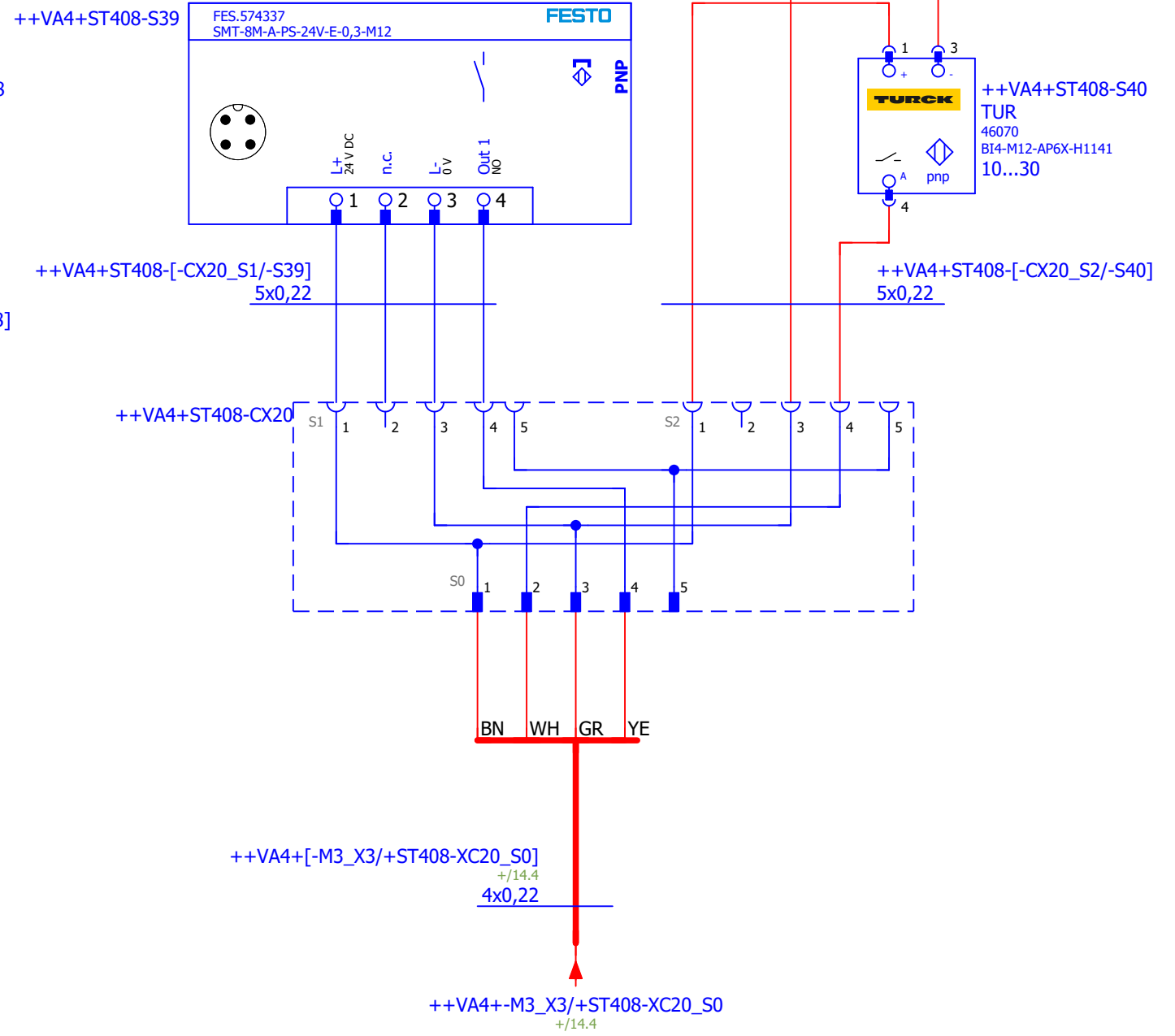
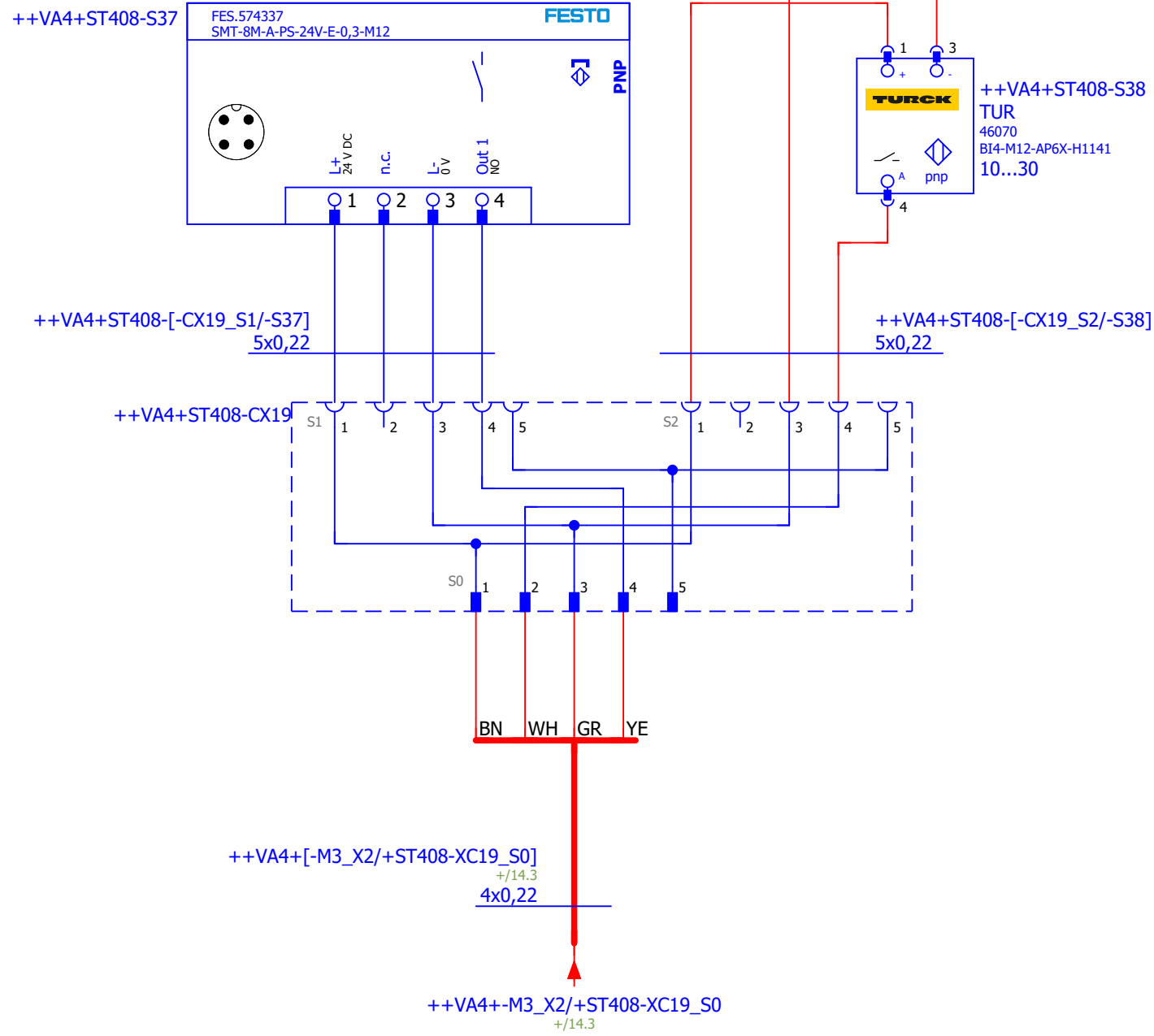

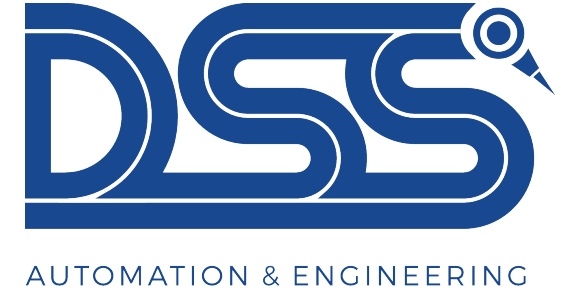

Müşteri : FORD OTOSAN

Üretici (şirket) : DSS OTOMASYON

+ST409



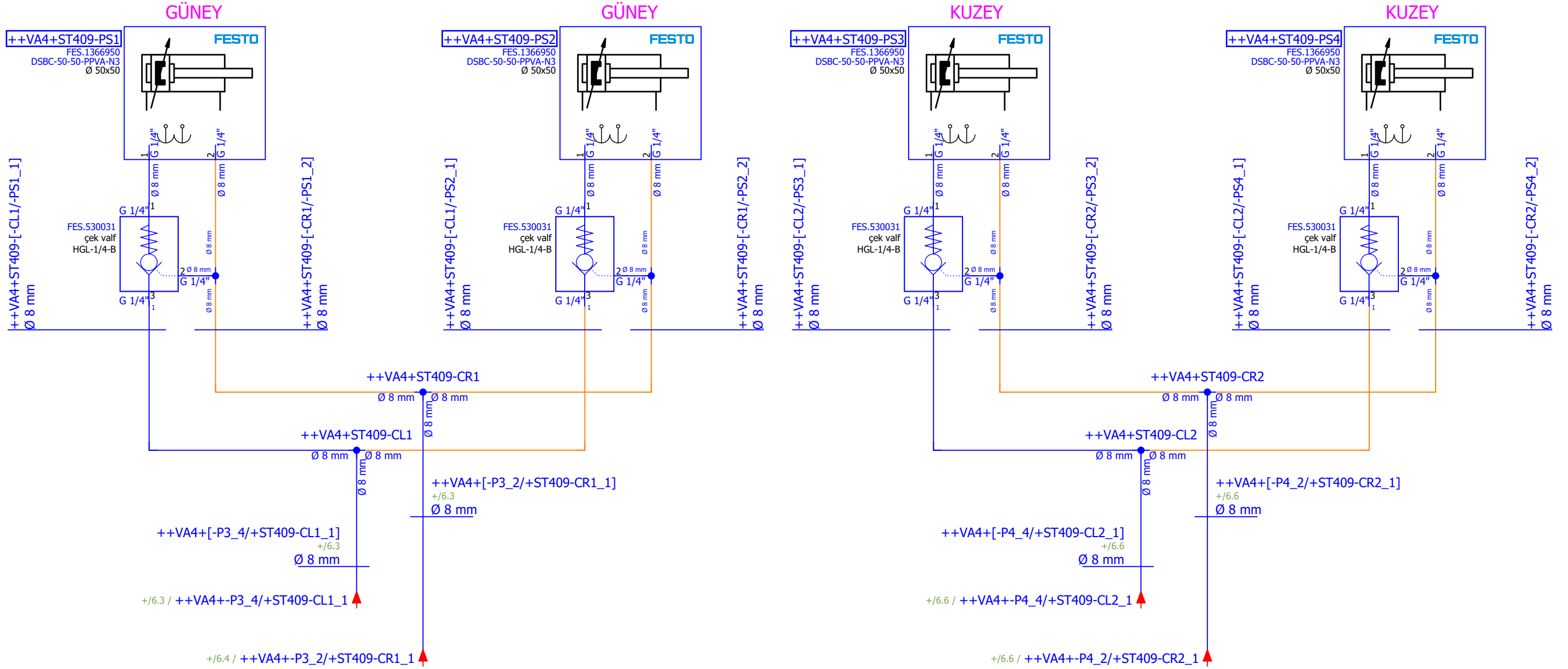

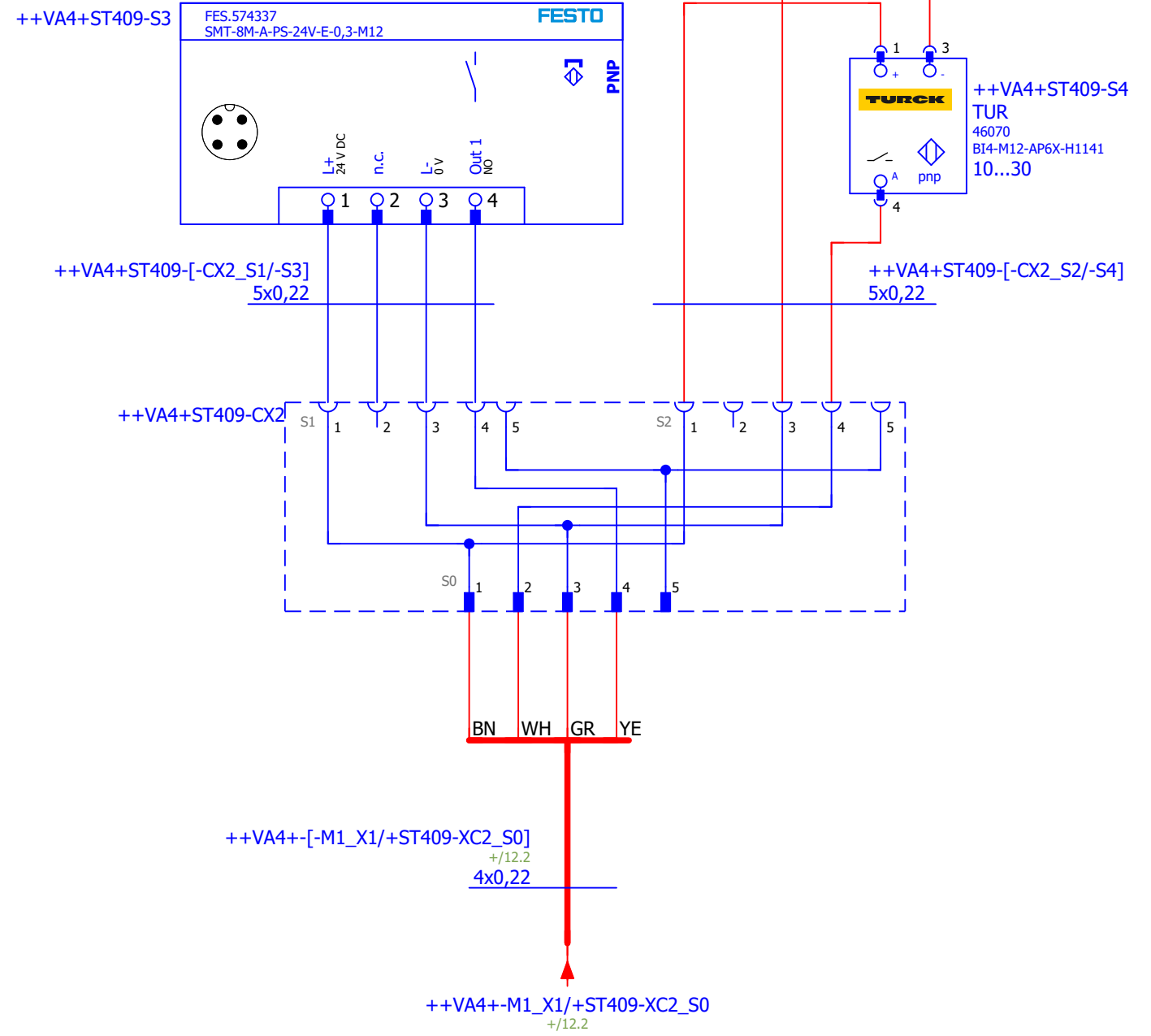
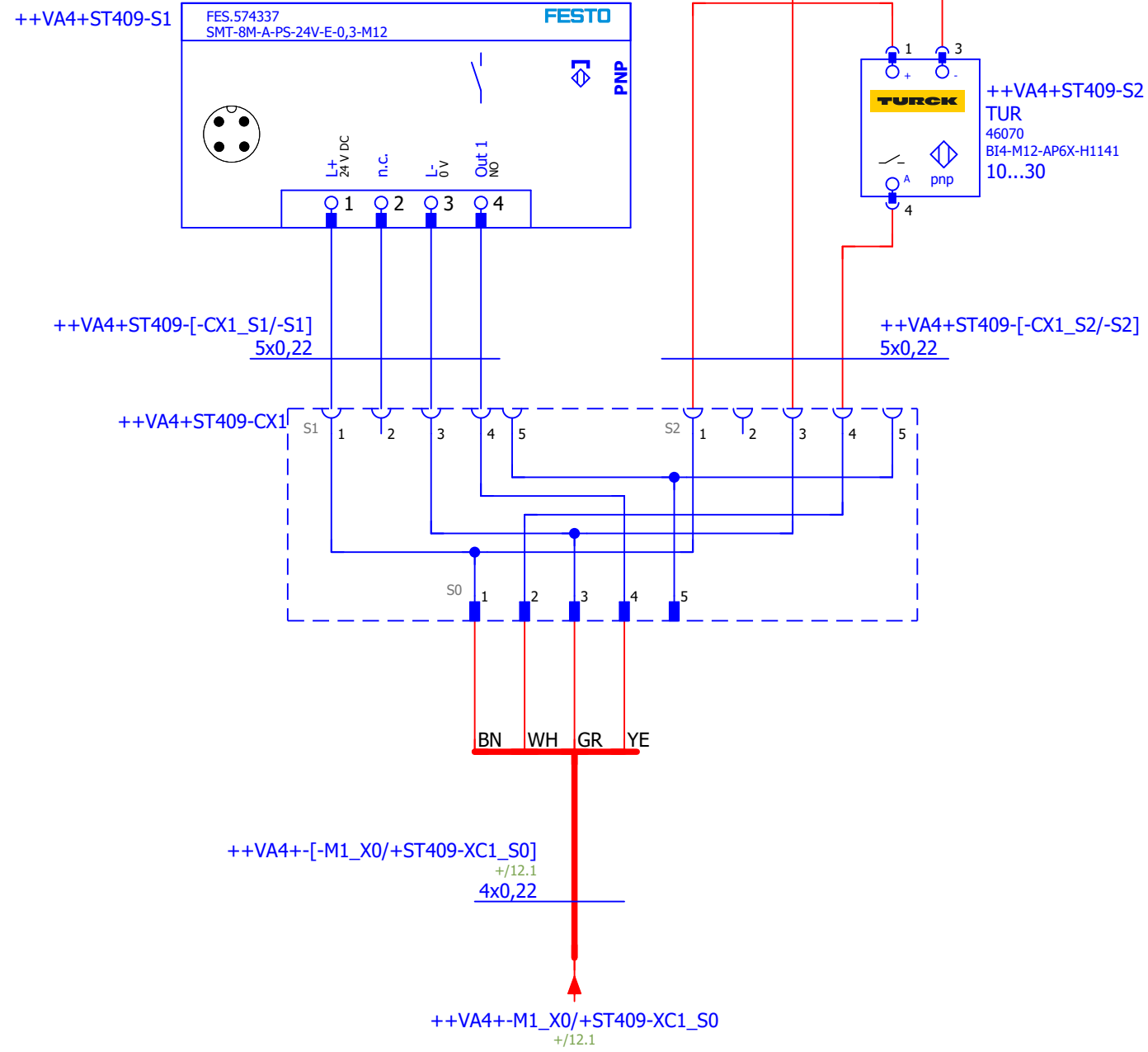



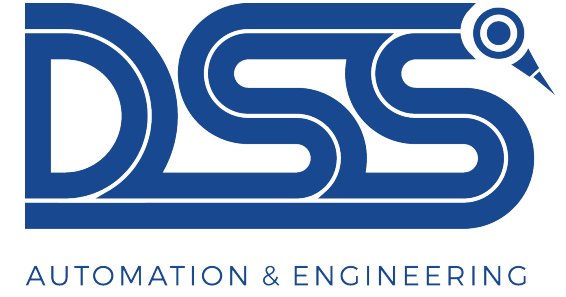

Müşteri : FORD OTOSAN

Üretici (şirket) : DSS OTOMASYON

+ST410



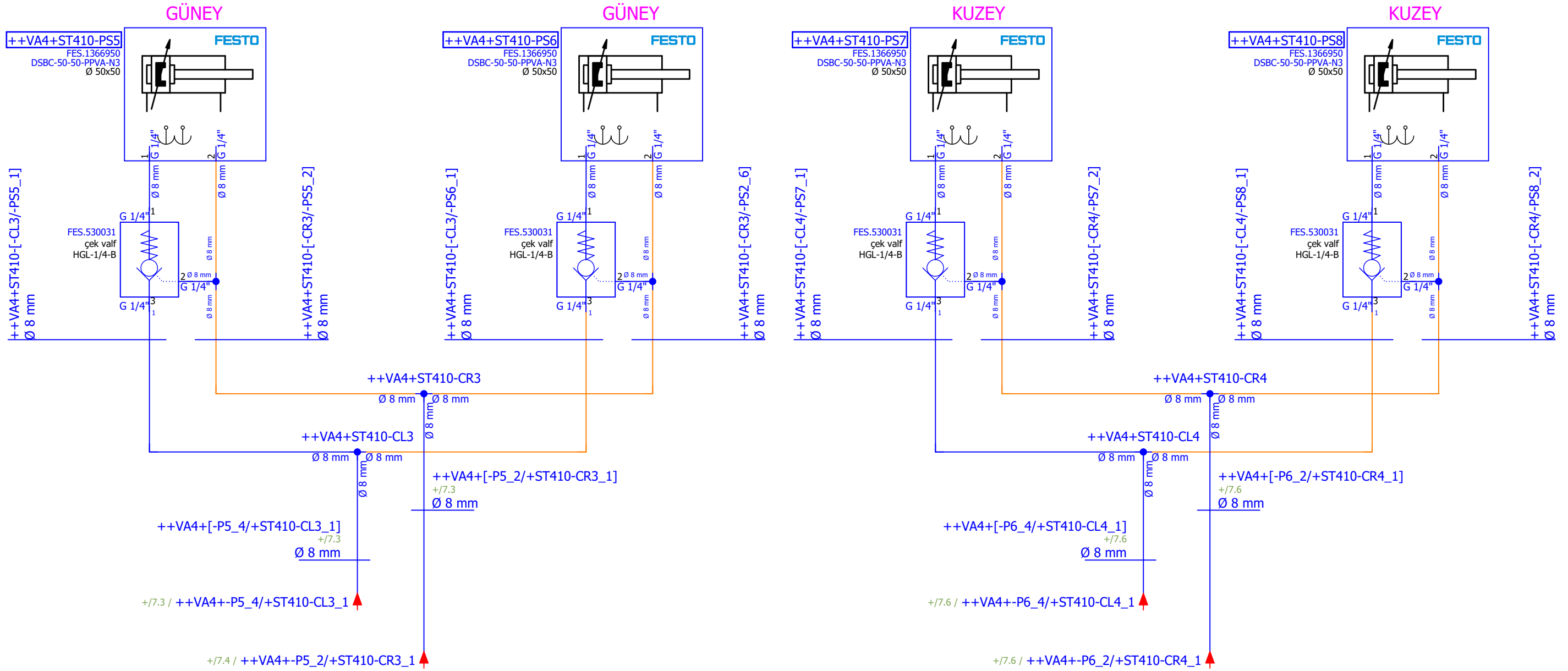

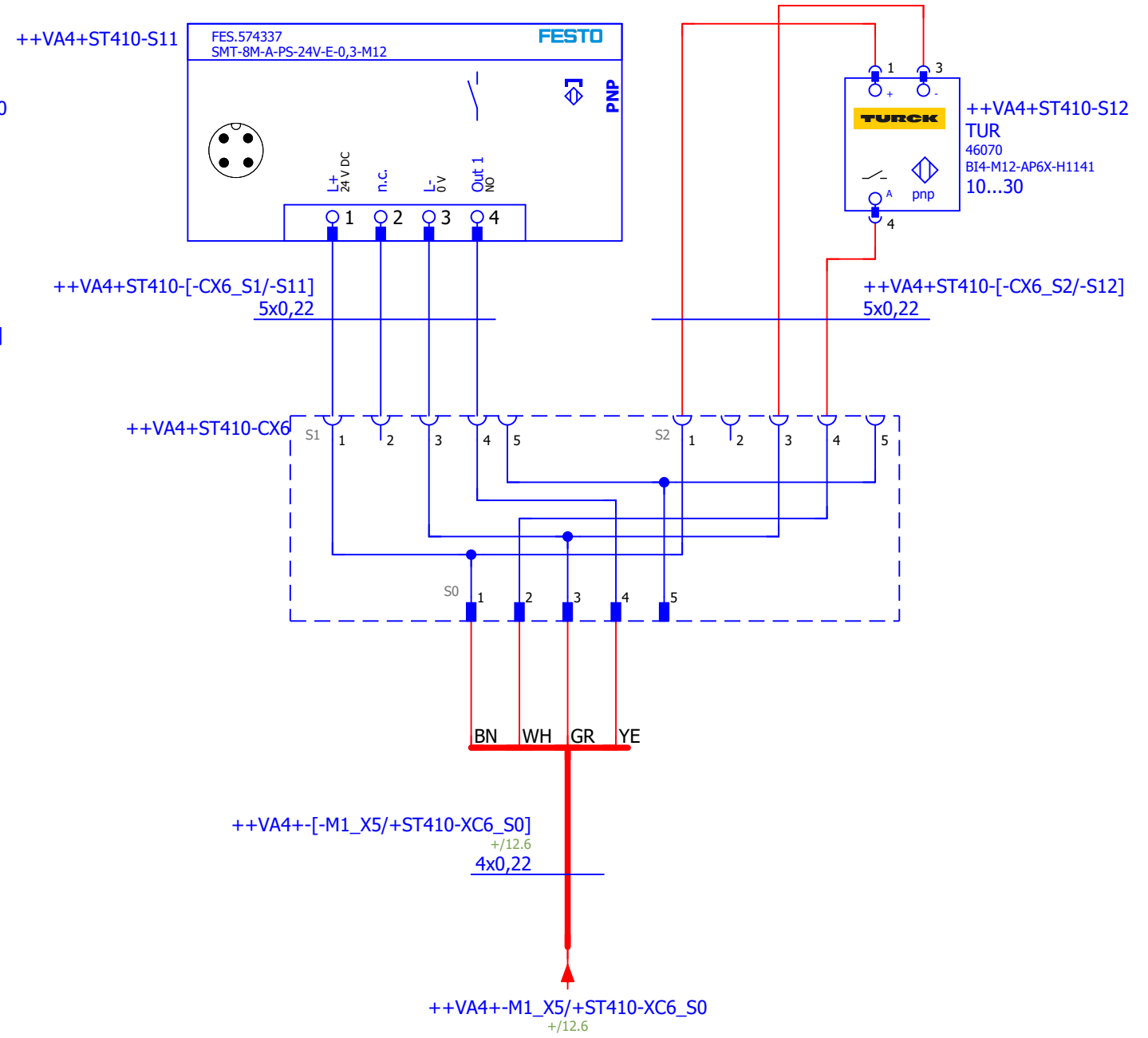
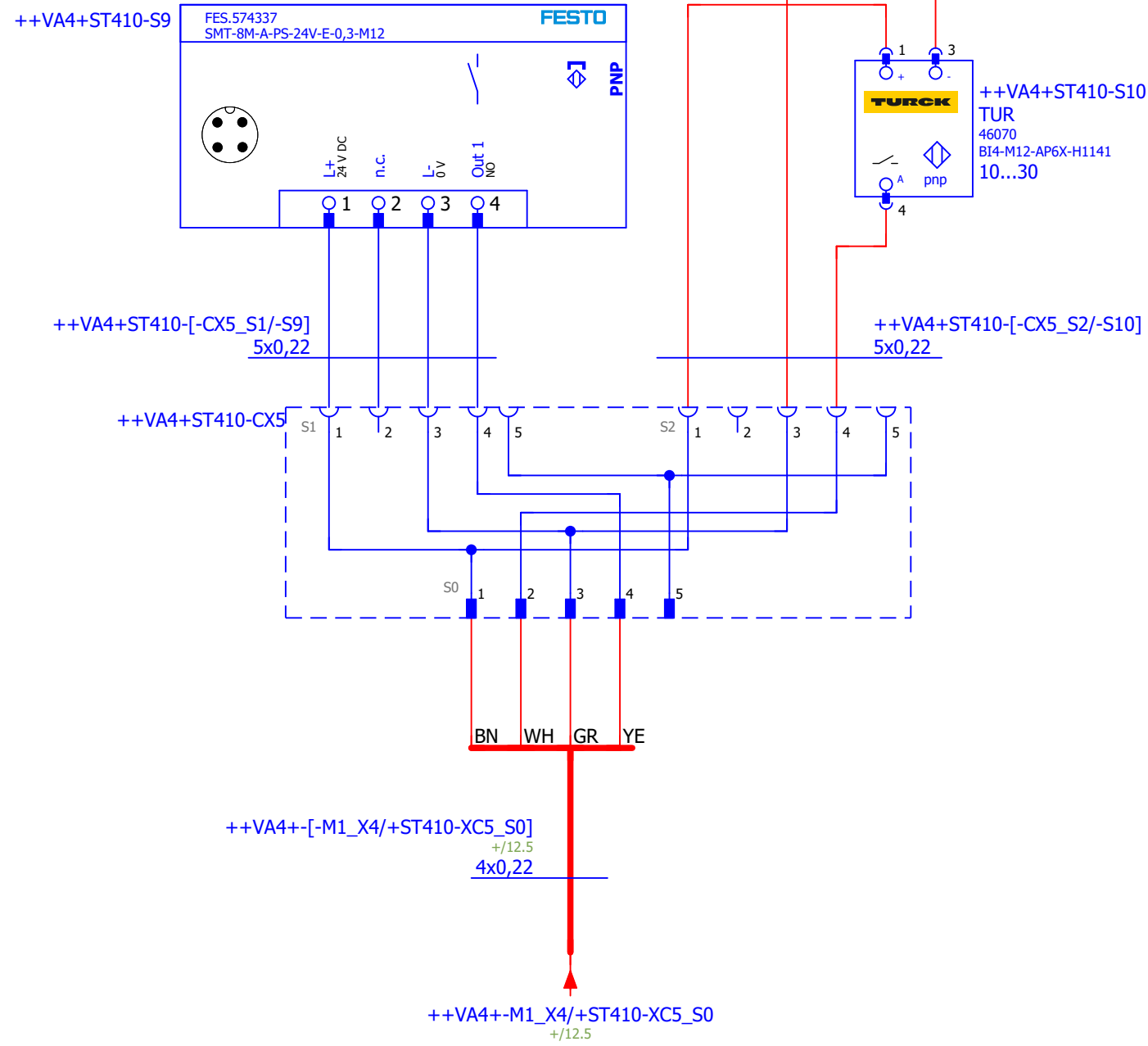

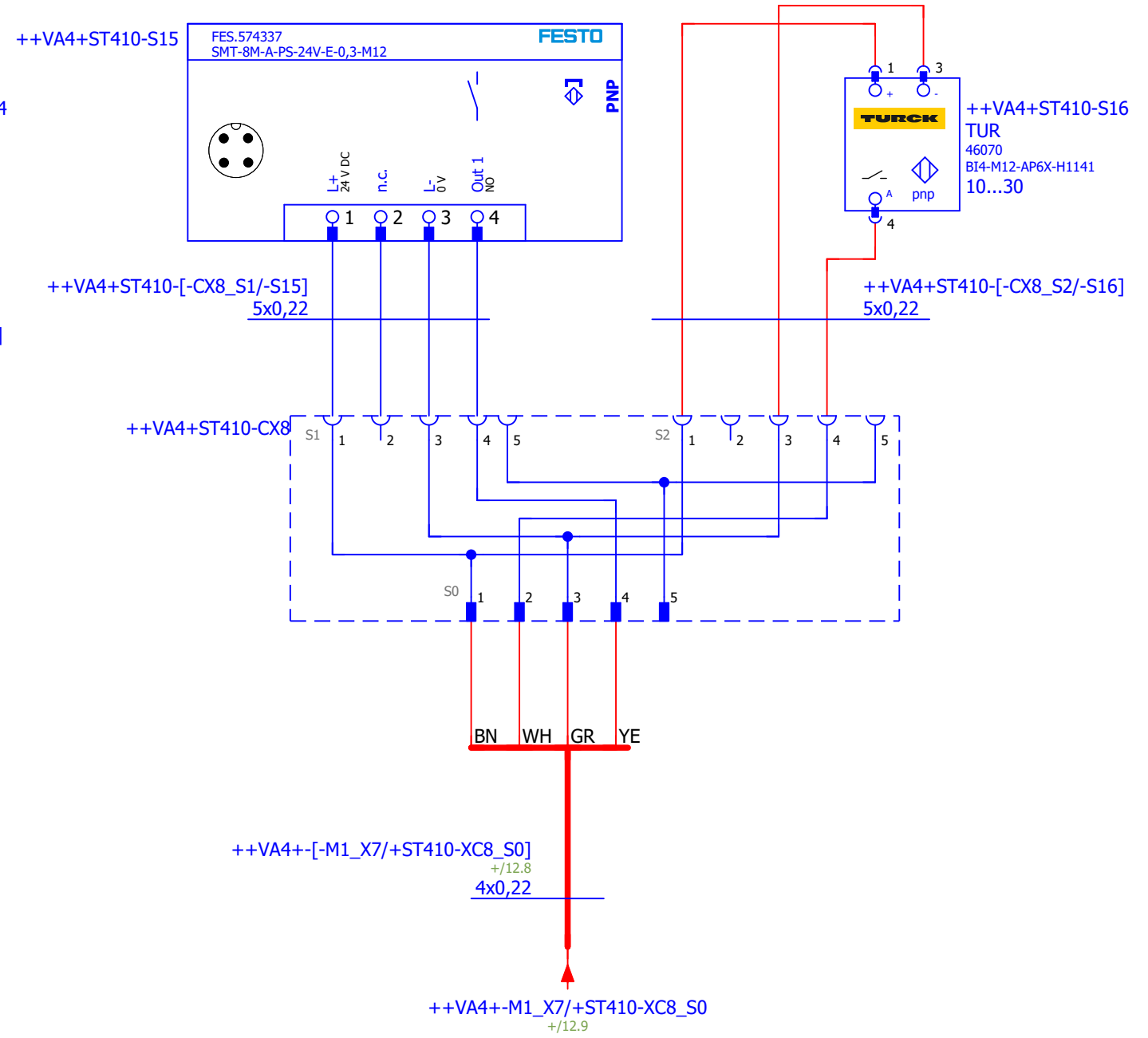
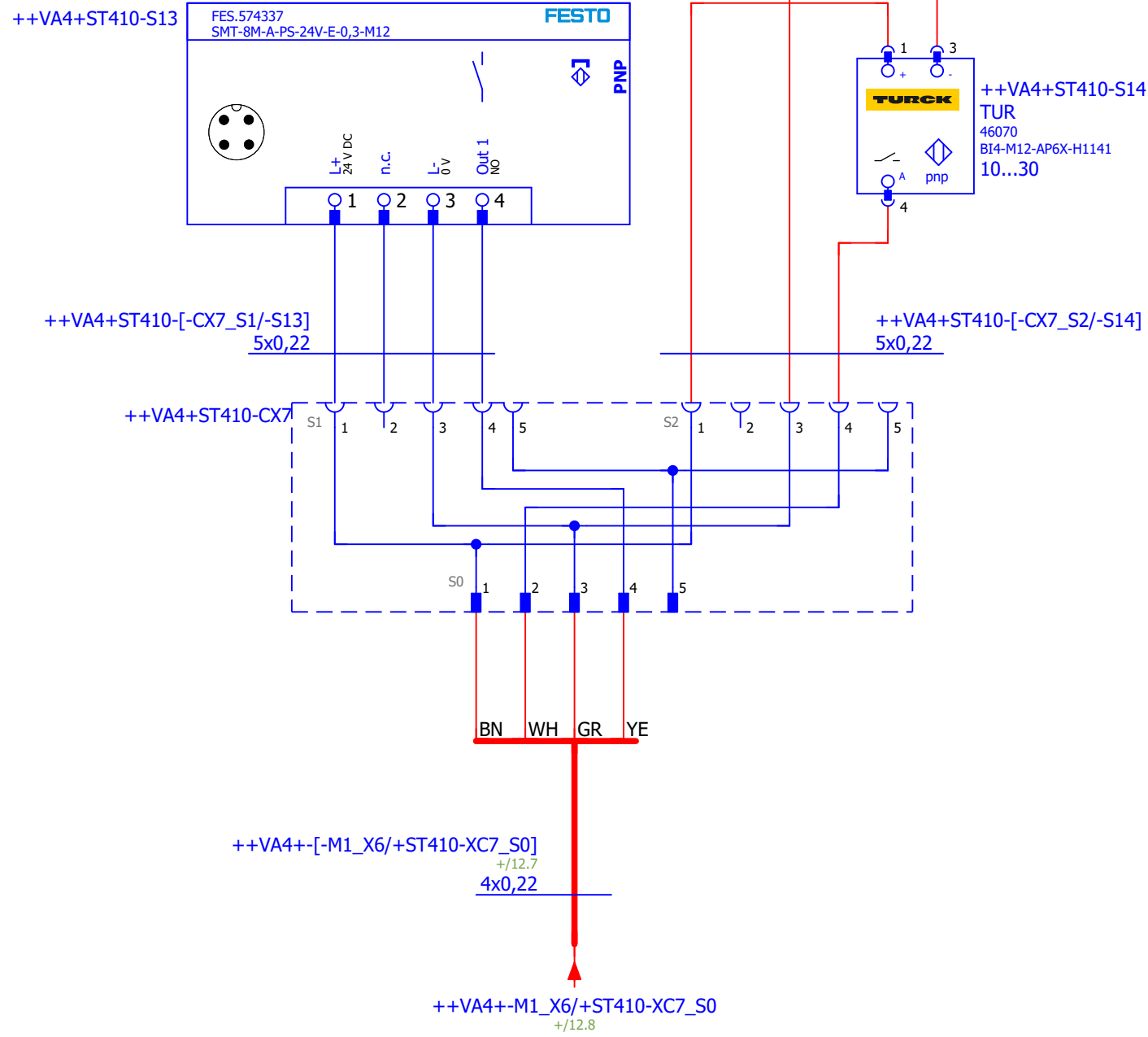

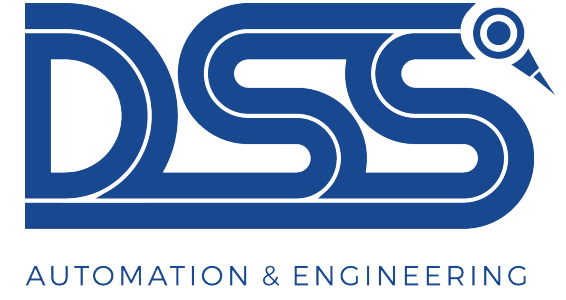

Müşteri : FORD OTOSAN

Üretici (şirket) : DSS OTOMASYON

+ST411



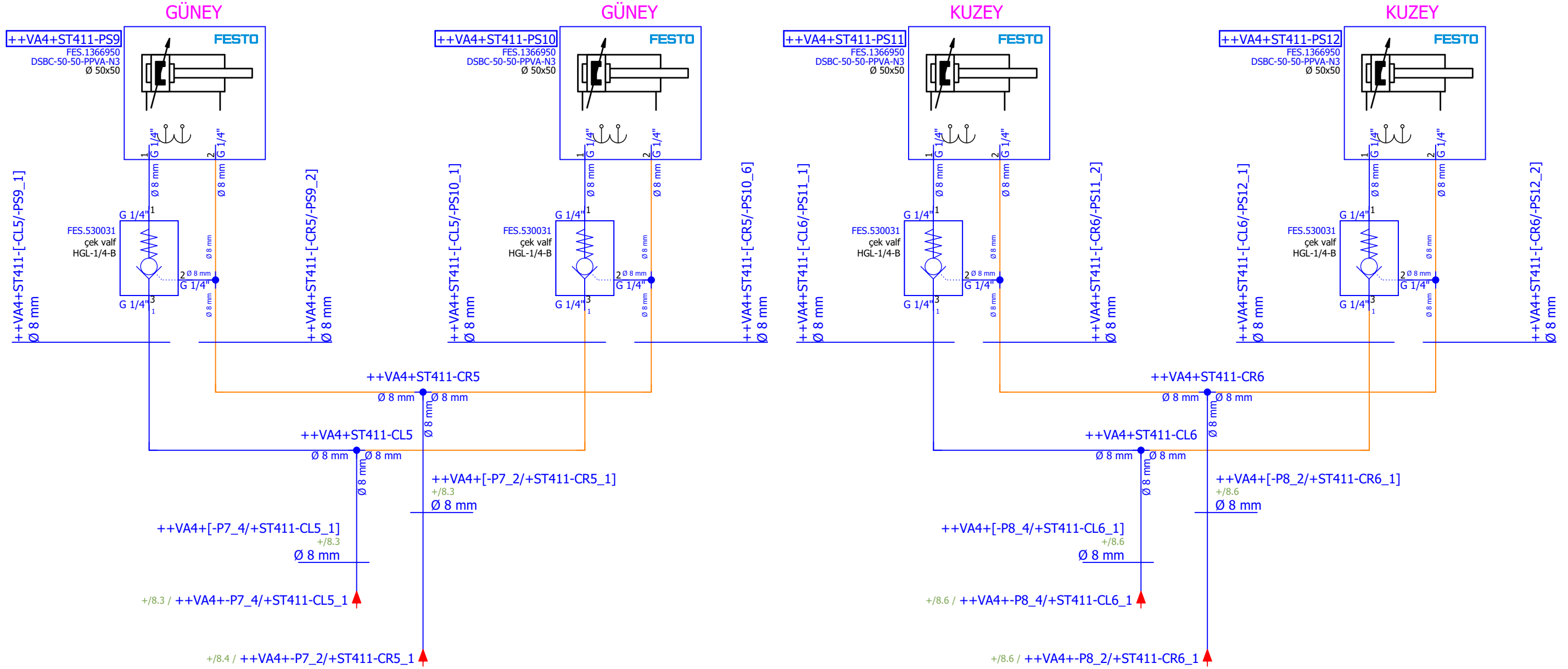

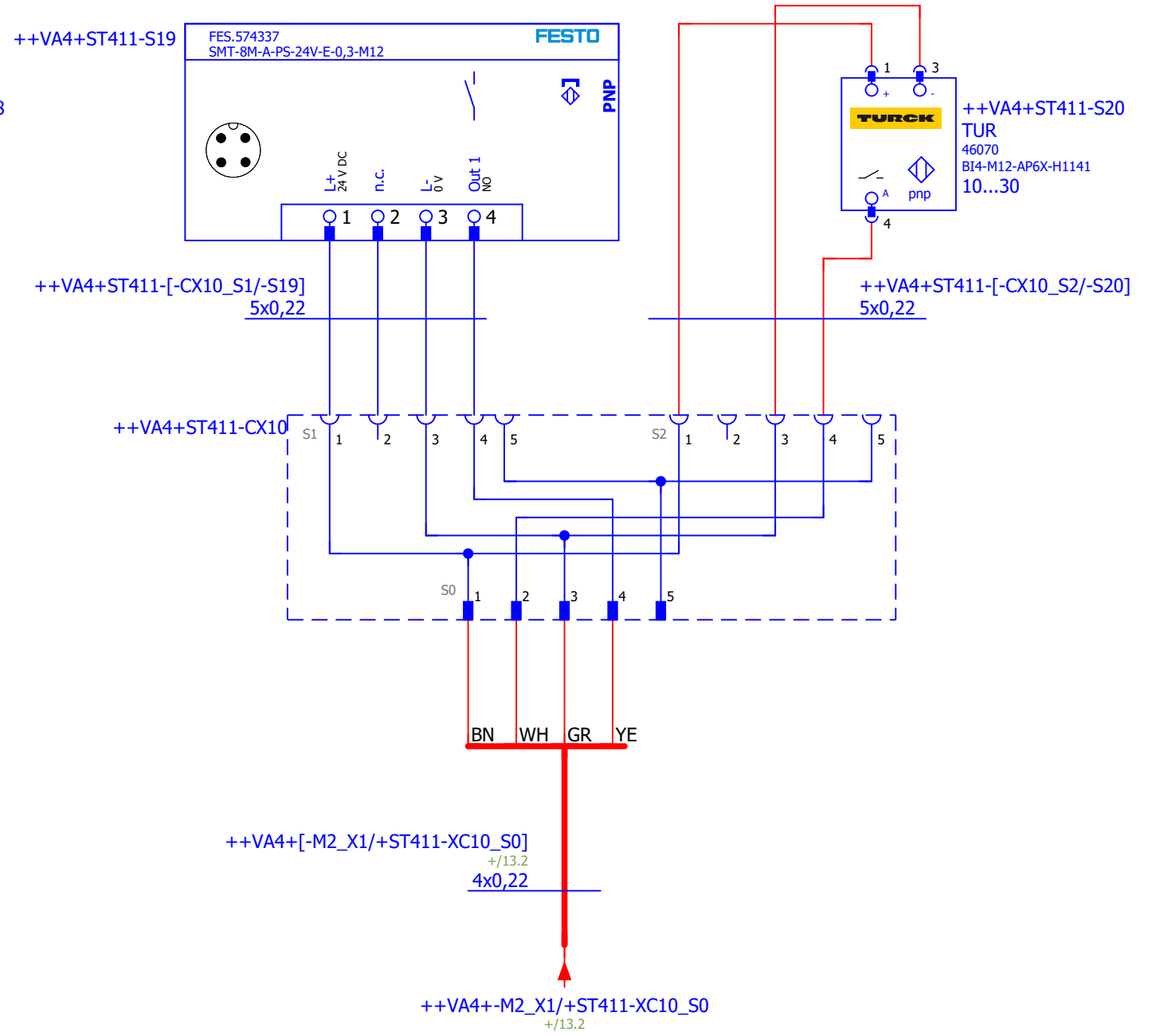
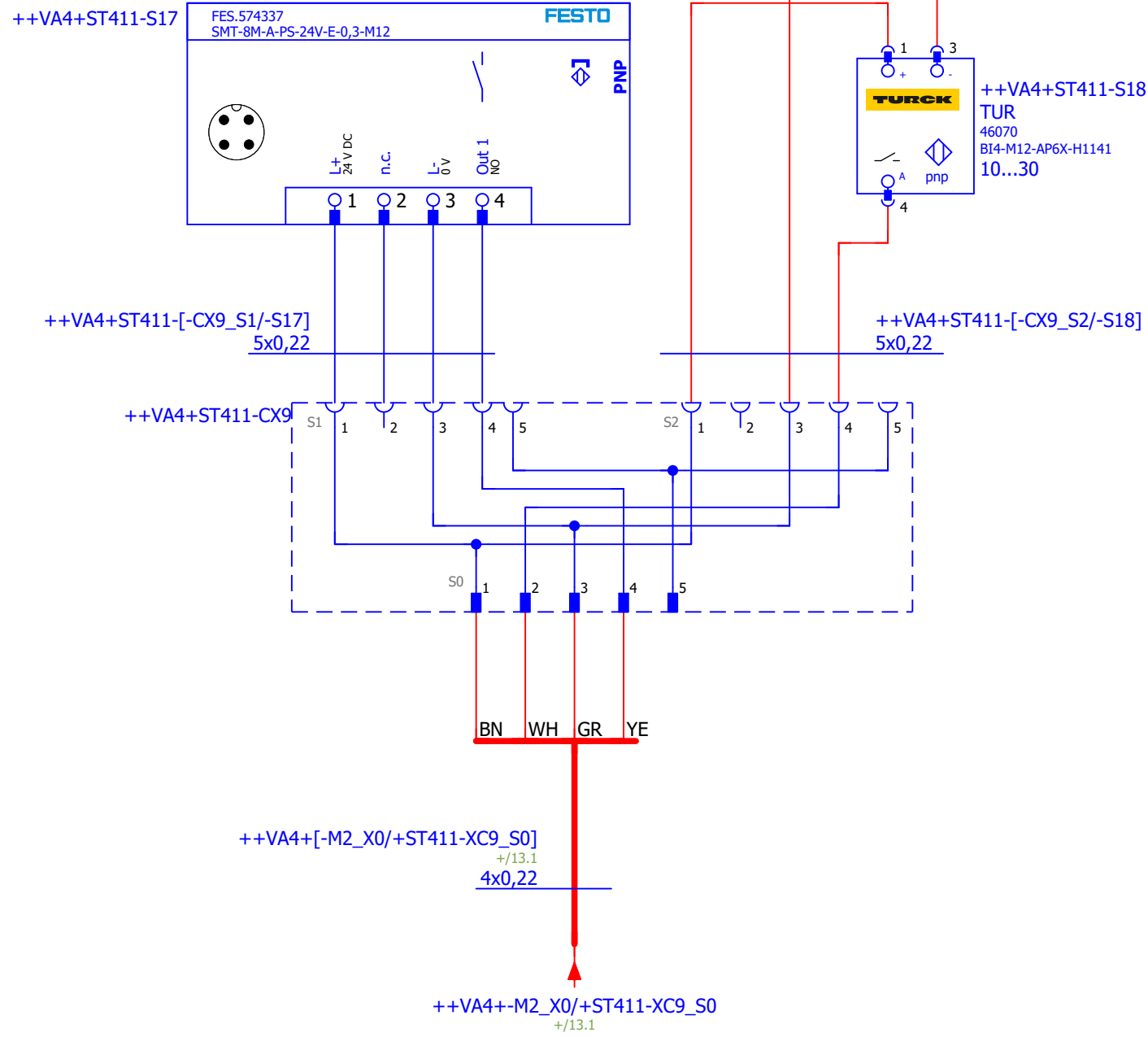

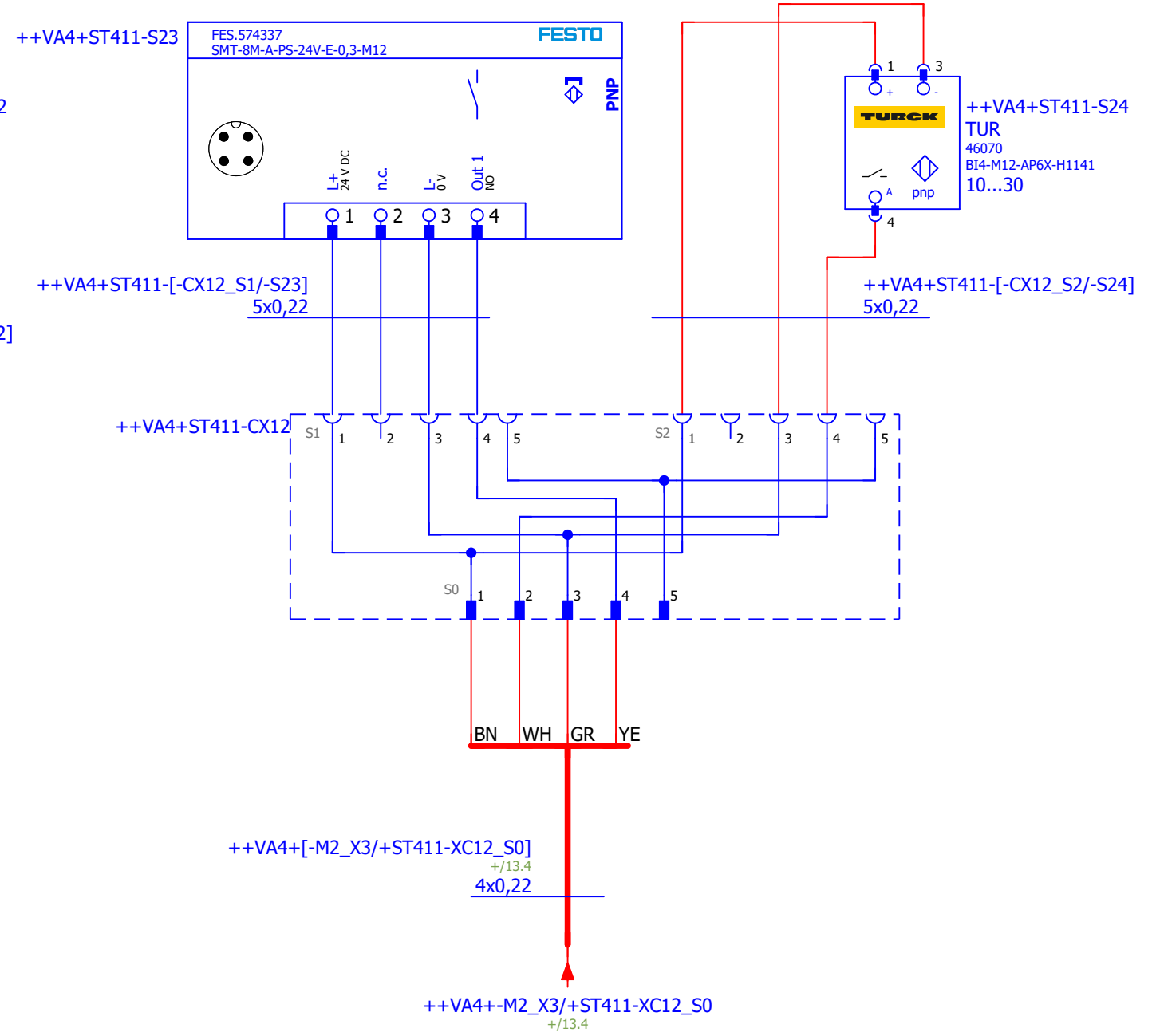
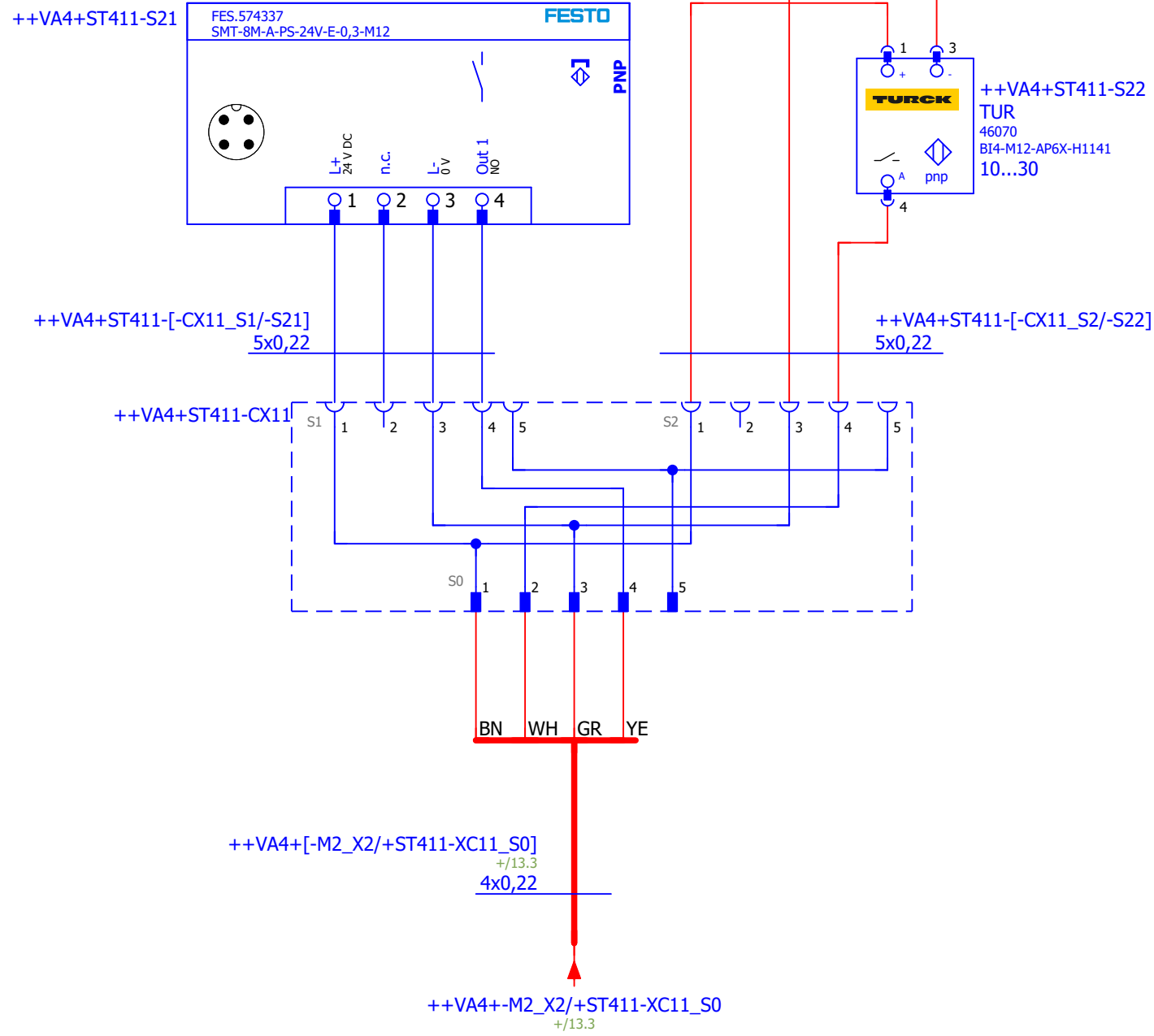

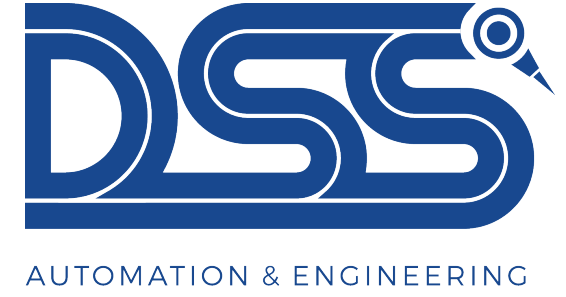

Müşteri : FORD OTOSAN

Üretici (şirket) : DSS OTOMASYON

+ST412



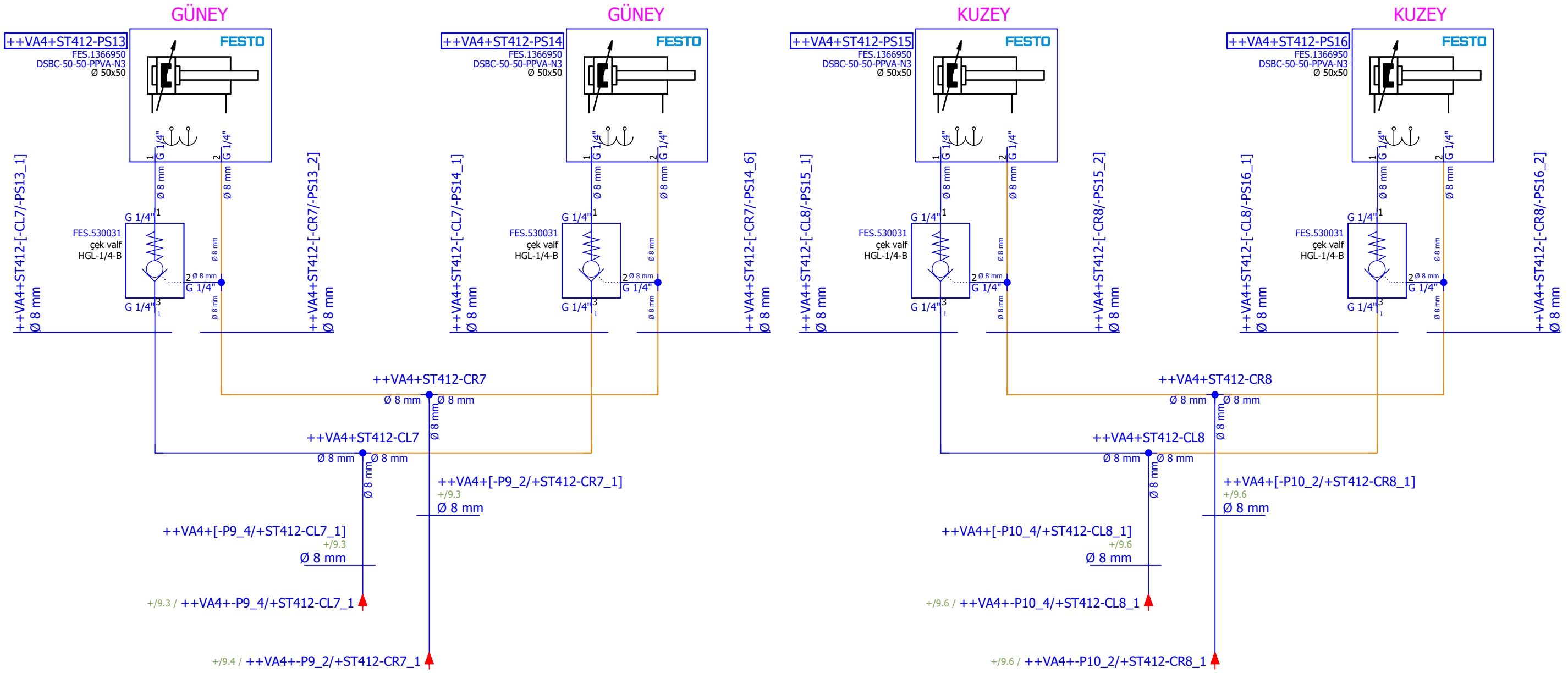

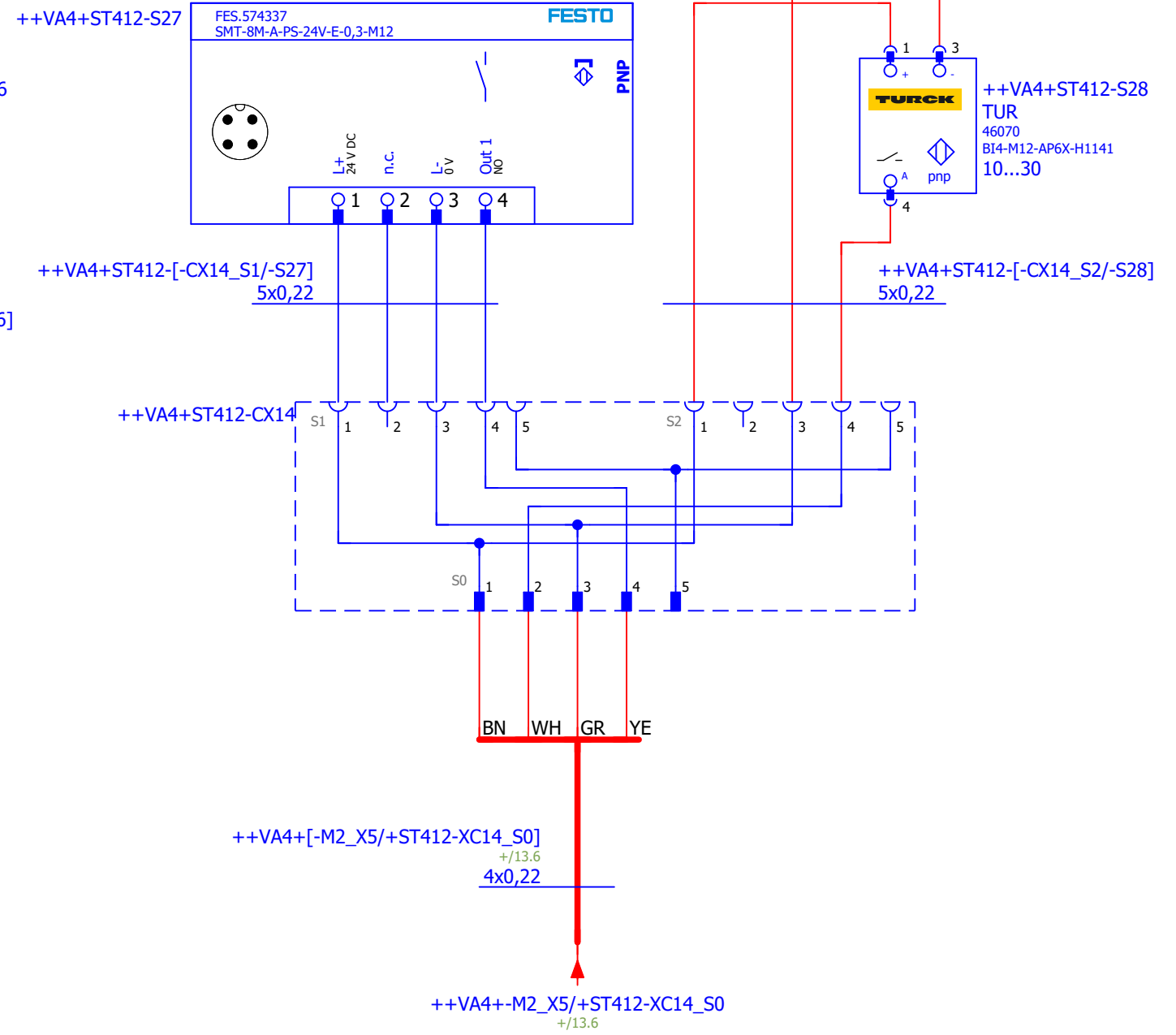
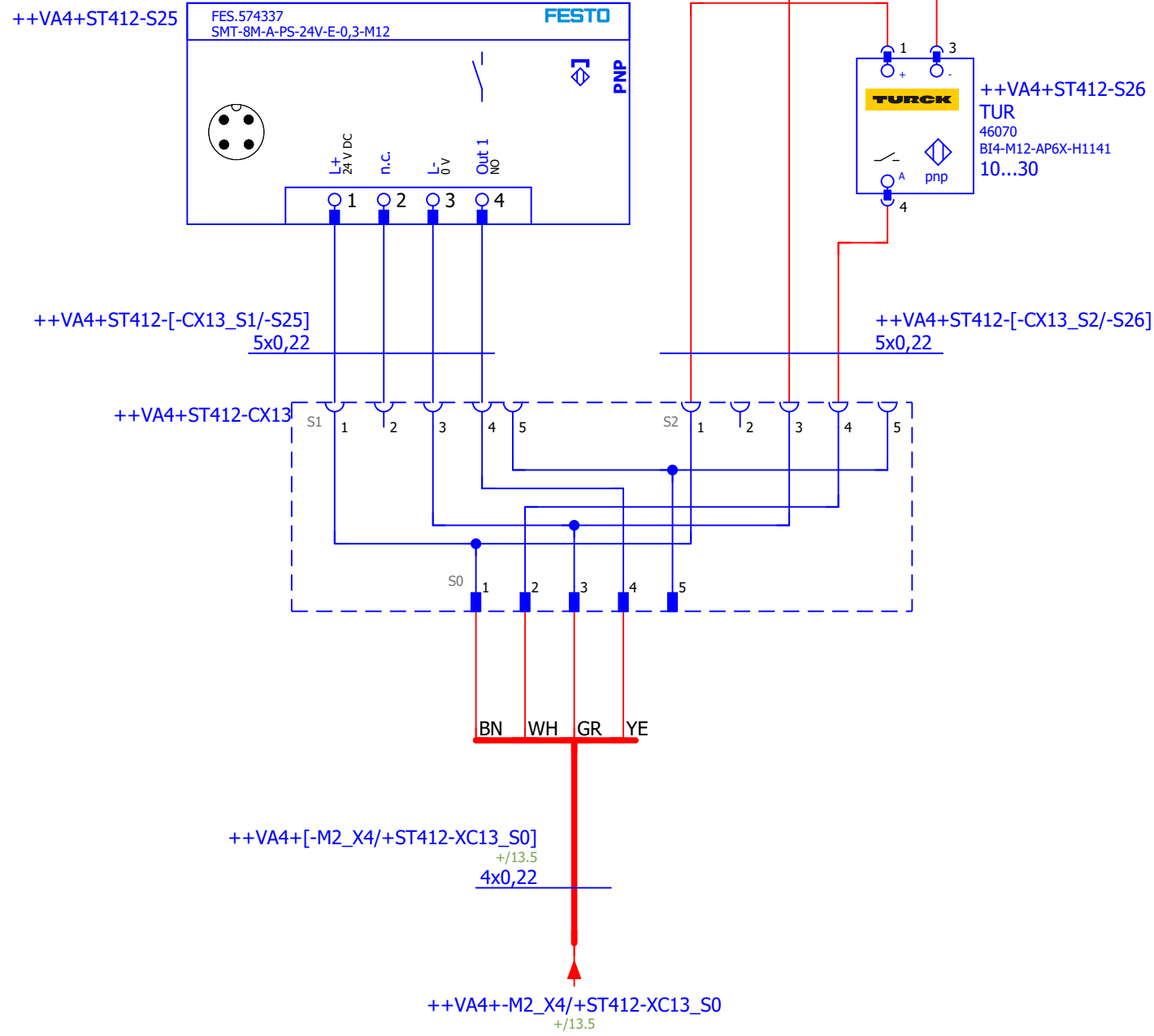

	Yeşilyurt, Muhtar Cafer Sk. No:8 41190 Başiskele/Kocaeli		<b>PROJE ADI</b>	<b>SAYFA AÇIKLAMASI</b>	Çizen: Hasancan Simen	Sayfa 32
	info@dssotomasyon.com.tr		PLC101 stoper	SENSÖRLER	Kontrol Eden: Sabri Ebrem	
	+90 544 322 23 10					

